

Centrifugal Fans

- backward curved impellers
- double inlet
- belt driven

Air in Motion.
Wolter Fans.

M08.HRZ

wolter 

Contents	Page 1
Technical description	Page 2
General information	Page 2
Fan casings	Page 2
Impellers	Page 2
Shaped inlets	Page 2
Shafts	Page 2
Bearings	Page 2
Fan type code	Page 3
Sound levels	Page 3
Performance curves	Page 3
Smoke spill operation	Page 4
Performance curves	Page 5
Dimensions	Page 20
Technical Informations	Page 28
Fan Laws - Proportional Laws	Page 28
Coordination fan plant	Page 29
1. Characteristic Fan Curve	Page 29
2. Characteristic Curve of the Plant (Resistance Parabola)	Page 29
3. Coordination between Fan and Plant	Page 2
Operating and maintenance instructions	Page 30

General information

This range of **Wolter** fans is the result of many years of research and development. The efficiency of all the fans is guaranteed through specific volume figures at maximum pressure differentials. Excellent performance and minimal noise levels are the features of this new fan range.

These centrifugal fans are designed for the conveyance of clean air and non-aggressive steam and gases at a temperature range from -30°C to +80°C (22°F to 176°F)

Type: HRZ (backward curved).

Computer design allows for interchange-ability of components which ultimately provides an economy product.

Component dimensions are in accordance with DIN 323 section R 20 which means that the nominal size corresponds with the outside diameter of the impeller.









Fan casings

The machine folded scroll is made of galvanized sheet metal. Pre-drilled holes are located in the side plates to fix mounting frames. It provides for easy installation.

The outlet flanges are in accordance with international standards DIN 24193 sheet 2.

Versions of casing

High performance centrifugal fan with folded galvanized scroll as standard:

Version	HRZ	Size Range	Description
00		315 ... 450	without accessories
01		315 ... 450	with standard outlet flange
02		315 ... 450	without outlet flange, with removable feet
03		315 ... 450	with standard outlet flange and removable feet
04		315 ... 630	without outlet flange, with galvanized rectangular frame
05		315 ... 630	with standard outlet flange, with galvanized rectangular frame
06		710 ... 1600	without outlet flange, with welded rectangular frame
07		710 ... 1600	with standard outlet flange with welded rectangular frame

Impellers

The torsion-resistant impellers guarantee a high standard of technology regarding volume flows and processing. The impellers with the shaft are statically and dynamically balanced on precision machines according to quality standard Q 2.5 of VDI 2060.

The backward curved impeller of the **HRZ** range are made of steel with powder coated.

All impeller series guarantee highest peripheral speed. The aero dynamical design stands for the precision of these modern high efficiency impellers.

For chemical resistance applications, both fan casing and impeller can be finished with special epoxy protection coating or fully manufactured in GRP (FRP) material.

Shaped inlets

The aerodynamically shaped inlets are bolted in and guarantee a perfect inlet stream onto the impeller.

Inlets for the type **HRZ** are made of steel with powder coated.

Shafts

All precision shafts are trued and have a smooth finish. Both shaft ends have as a standard feature diameters complying with DIN 748, sheet 1 and a groove (DIN 6885, sheet 1) with locking spring. A wax coating provides protection against corrosion of this precision engineered shaft.

Bearings

The low noise precision ball bearings are designed for a theoretical life of at least 40.000 working hours. Limiting values for speed and power are indicated on the characteristic curves and should not be exceeded. Long term quality is safeguarded when general assembly and service guidelines for V-belt drives are adhered to.

Fan type code

H R Z 05 500

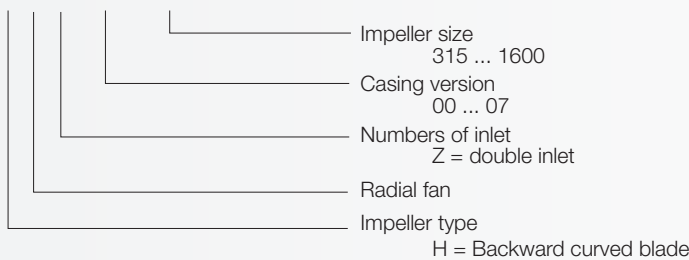

HRZ 315 to 630 of version 00 to 05

The grooved ball bearings in the harmonic strut housings are completely sealed and maintenance free. Unavoidable alignment errors in the sheet metal casing are compensated by the spherical outer ring. The insulating rubber rings absorbing vibration and structure-born noise are temperature and chemical resistant and electrical conductors. The rugged sealing rings and the inner rings of the bearings are galvanized. The flexible bearing cage is made from polyamide.

The bearing is attached to the shaft by means of an eccentric tension ring. In order to guarantee the bearing seat is free from play and to avoid corrosion of the tension ring it is sealed with a liquid synthetic.

HRZ 710 to 1600 of version 06 to 07

The grooved ball bearings in the rugged cast-iron casings are completely sealed and maintenance free. Unavoidable alignment errors are compensated by the spherical outer ring. The one-piece bearing housing conforms to DIN 626 Part 213 (ISO 3228) and allows full utilization of the carrying capacity of the mounted regulating bearing.

All housings are equipped with lubricating bore holes for the possibility of secondary lubrication. As protection the lubricating bore holes are closed with a synthetic stopper.

For corrosion reasons the rugged sealing rings and the bearing inner ring are galvanized. The flexible bearing cage is made of polyamide.

The bearing is attached to the shaft by means of an eccentric tension ring. In order to guarantee the bearing fit is free from play and to avoid corrosion of the tension ring it is sealed with a liquid synthetic.

Sound levels

In order to make possible an assessment of sound projection adequate to the human ear the A-assessed description of sound levels has been chosen. The ascertaining of the sound power level follows the reverberant room method according to AMCA 300.

The sound power levels shown on each performance curve, LwiA, refer to the overall sound power "A-Weighted" levels. The computed sound power levels were converted into A-Weighted levels using adjustments to the octave band spectrum as follows:

Centre Frequency Hz	63	125	250	500	1000	2000	4000	8000
A-Weighted Adjustment dB(A)	-26.2	-16.1	-8.6	-3.2	0	+1.2	+1.0	-1.1

The overall sound pressure levels, LpiA, can be calculated from the overall sound power levels as follows:

1) Free Field Conditions: $L_{piA} = L_{wiA} - (20 \log_{10} d) - 11$

2) Room Conditions: $L_{piA} = L_{wiA} - (20 \log_{10} d) - 7$

Where: d = distance from fan in meters.

Performance curves

The performance curves have been established using the outlet test method in the test chamber according to AMCA 210 installation B (free inlet, ducted outlet).

The curves indicate as a function of the volume flow:

- the total pressure increase Δp_{tot} for constant speed (heavy black lines)
- constant lines of shaft power P_w (red Lines)
- constant lines of sound power level LwiA (blue lines)

All values relate to an air density:

$\rho_1 = 1,2 \text{ kg/m}^3 \text{ at } 20^\circ\text{C}$

The dynamic pressure p_{d2} and the flow speed c_2 respectively stated in the diagrams refer to the flange cross section of the outlet connection pieces.

Motor power

The powers (P_w) provided on the performance curve are the internal powers required by the ventilator and do not include the mechanical losses. To compute the total required shaft input power, the internal power must be divided by the mechanical efficiency:

$$P_s = P_w / \eta_m$$

where: P_s = total required shaft input power

η_m = mechanical efficiency

The mechanical efficiency is provided as follow:

Way of ventilator driving	η_m
Electric motor directly driven	1
Coupling directly driven	0,98
V-belt driven	0,95

The performance curves provided in this catalogue were measured according to AMCA 210 (ISO 5801) in a test chamber. The sketch below shows the principle set up of the test chamber.

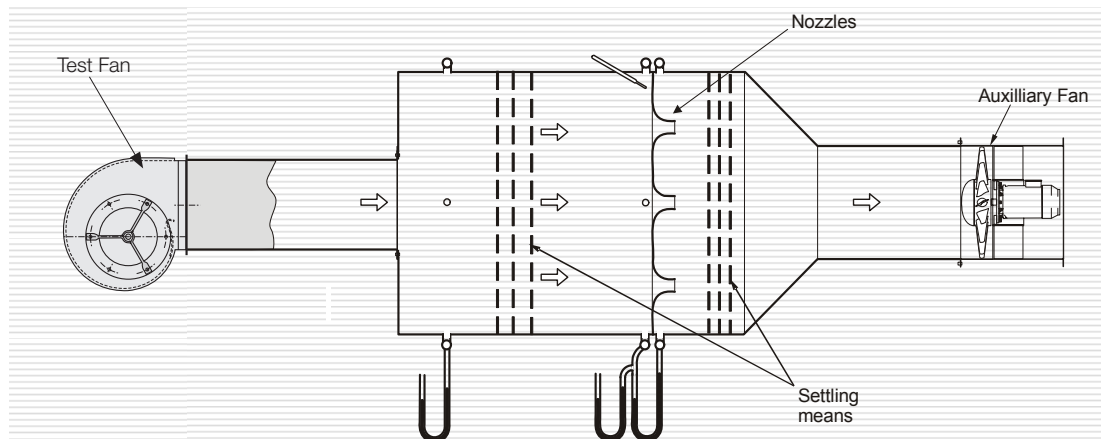

AMCA 210 Figure 12
ISO 5801 Figure 73b

Smoke spill operation

The HRZ range of backward curve centrifugal fans are designed and tested to operate at standard temperatures as well as at elevated temperatures of maximum up to 600deg/C for 240 minutes inclusive of F600 (600deg/120mins), F400 (400deg/120mins) and F300 (300deg/60mins) according to EN 12101-3:2015.

Design Features

Cabinets with belt-driven fans can be fitted with double-inlet fans & related accessories

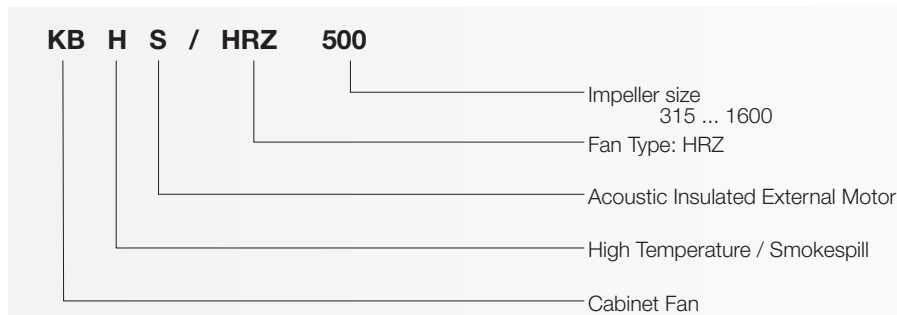

Cabinet

- Frames made of extruded aluminium profiles, joined together by either plastic or aluminium corners
- Side panels made of galvanised sheet metal with optional epoxy coating
- Panels are insulated to ensure low noise levels
- Optional access door on service side
- Weatherproof version with aluminium side plates and weather-hood available
- For smoke spill operation, cabinet with externally located motor/s can be designed with or without acoustic insulation for the motors as well.

Installation and maintenance

- Interchangeable side panels allow easy installation
- Low-maintenance operation
- Electrical connection via waterproof terminal box

The following ancillary equipment is available.

Flexible connection

The flexible connection consists of two galvanised flanges, assembled with gas-tight canvas. Please note that the dimensions of inlet and outlet flexible connectors for a respective cabinet fan can differ.

Inlet and outlet flanges

Galvanised matching flanges for inlet and outlet sides are available.

Performance Curve

HRZ 315



Fan test laboratory AMCA 210/99
Fig.12, 140000 cmh Test Chamber.
Performance obtained is for installation type B-Free inlet, Ducted outlet.

Power rating (kW) does not include transmission losses, Performance ratings do not include the effects of appurtenances (accessories). The A-weighted sound ratings shown have been calculated per AMCA International Standard 301. Values shown are for inlet LwA sound power levels for installation Type B: free inlet, ducted outlet.

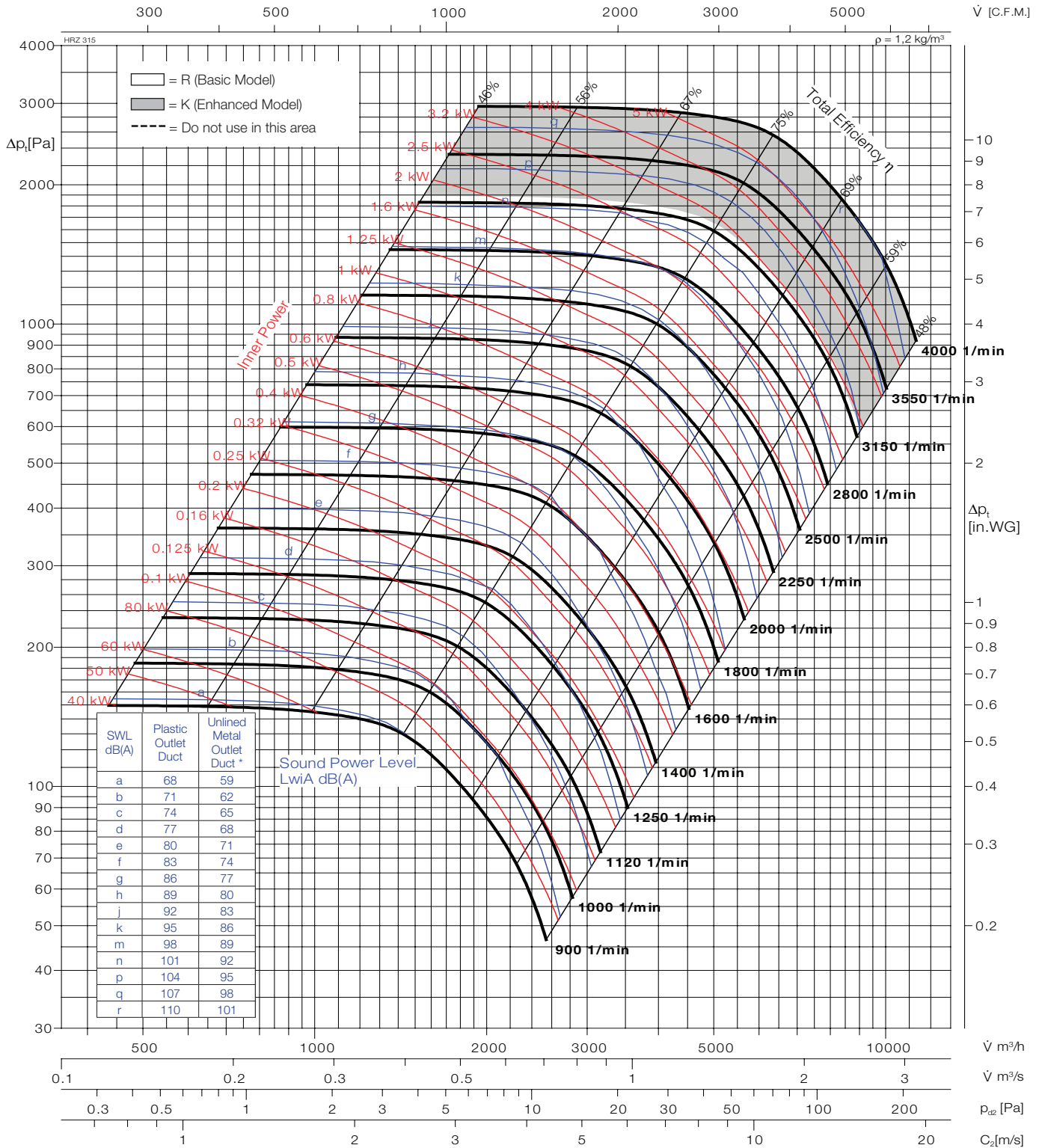

Typ	Art.Nr.	W [kg]	Typ	Art.Nr.	W [kg]
HRZ 03 315	541405	32,6			
HRZ 05 315	541407	42,6			

Wheel diameter	D = 319 mm
Number of blades	z = 16
Moment of inertia	J = 0,5211 kgm²
Wheel weight	G = 7,3 kg
Speed limit	n_{max} = 4000 1/min

Performance Curve

HRZ 355



Fan test laboratory AMCA 210/99
Fig.12, 140000 cmh Test Chamber.
Performance obtained is for installation type B-Free inlet, Ducted outlet.

Power rating (kW) does not include transmission losses, Performance ratings do not include the effects of appurtenances (accessories). The A-weighted sound ratings shown have been calculated per AMCA International Standard 301. Values shown are for inlet LwA sound power levels for installation Type B: free inlet, ducted outlet.

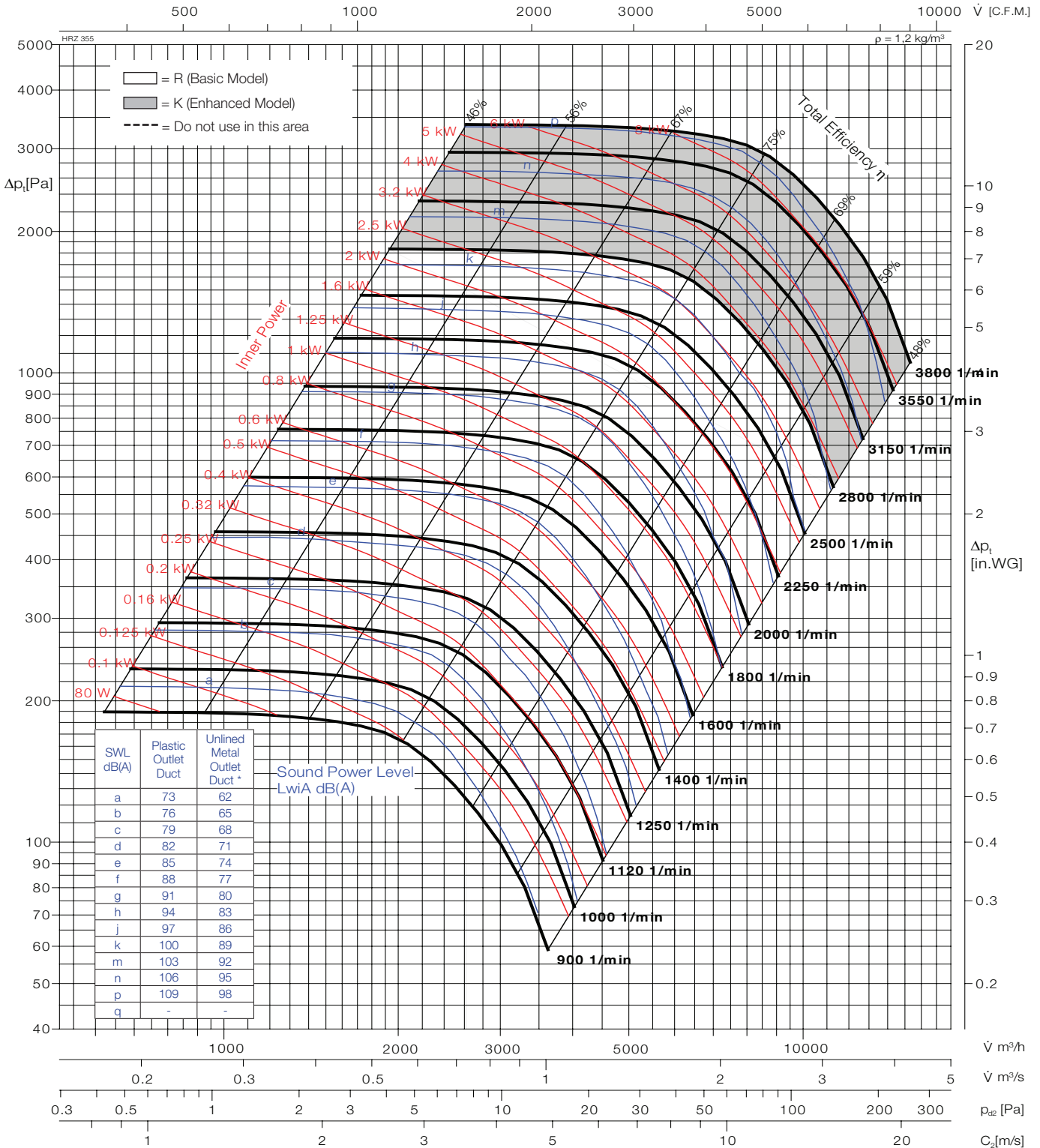

Typ	Art.Nr.	█ [kg]	Typ	Art.Nr.	█ [kg]
HRZ 03 355	541453	42,7			
HRZ 05 355	541455	54,7			

Wheel diameter	D = 359 mm
Number of blades	z = 16
Moment of inertia	J = 0,8204 kgm²
Wheel weight	G = 9,1 kg
Speed limit	n_{max} = 3800 1/min

Performance Curve

HRZ 400



Fan test laboratory AMCA 210/99
Fig.12, 140000 cmh Test Chamber.
Performance obtained is for installation
type B-Free inlet, Ducted outlet.

Power rating (kW) does not include transmission losses, Performance ratings do not include the effects of appurtenances (accessories). The A-weighted sound ratings shown have been calculated per AMCA International Standard 301. Values shown are for LwiA sound power levels for installation Type B: free inlet, ducted outlet.

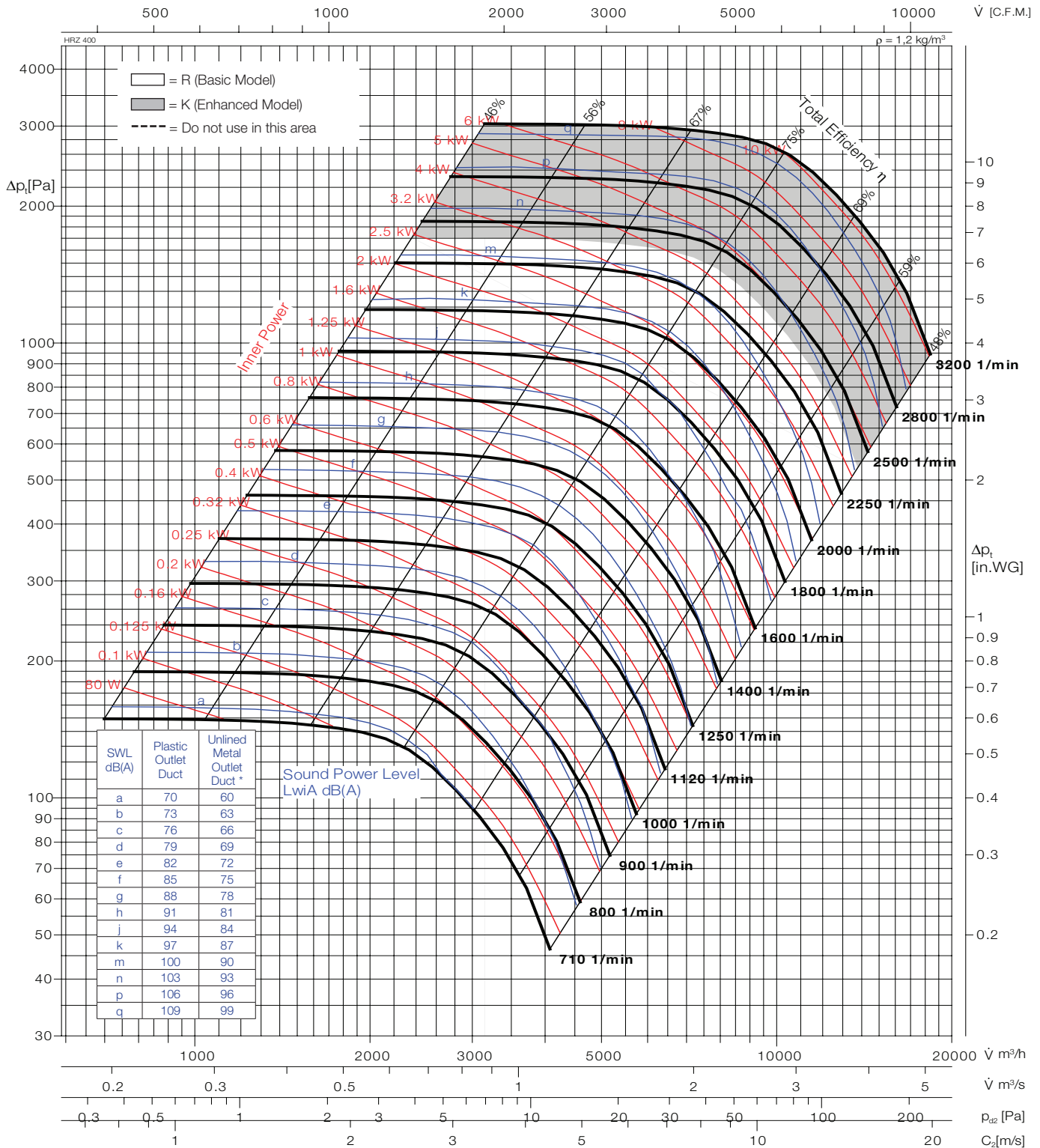

Typ	Art.Nr.	W [kg]	Typ	Art.Nr.	W [kg]
HRZ 03 400	541503	50,6			
HRZ 05 400	541505	63,6			

Wheel diameter	D = 404 mm
Number of blades	z = 16
Moment of inertia	J = 1,549 kgm²
Wheel weight	G = 13,6 kg
Speed limit	n_{max} = 3200 1/min

Performance Curve

HRZ 450



Fan test laboratory AMCA 210/99
Fig.12, 140000 cmh Test Chamber.
Performance obtained is for installation
type B-Free inlet, Ducted outlet.

Power rating (kW) does not include transmission losses, Performance ratings do not include the effects of aperturancs (accessories). The A-weighted sound shown have been calculated per AMCA International Standard 301. Values shown are for inlet LwIA sound power levels for installation Type B: free inlet, ducted outlet.

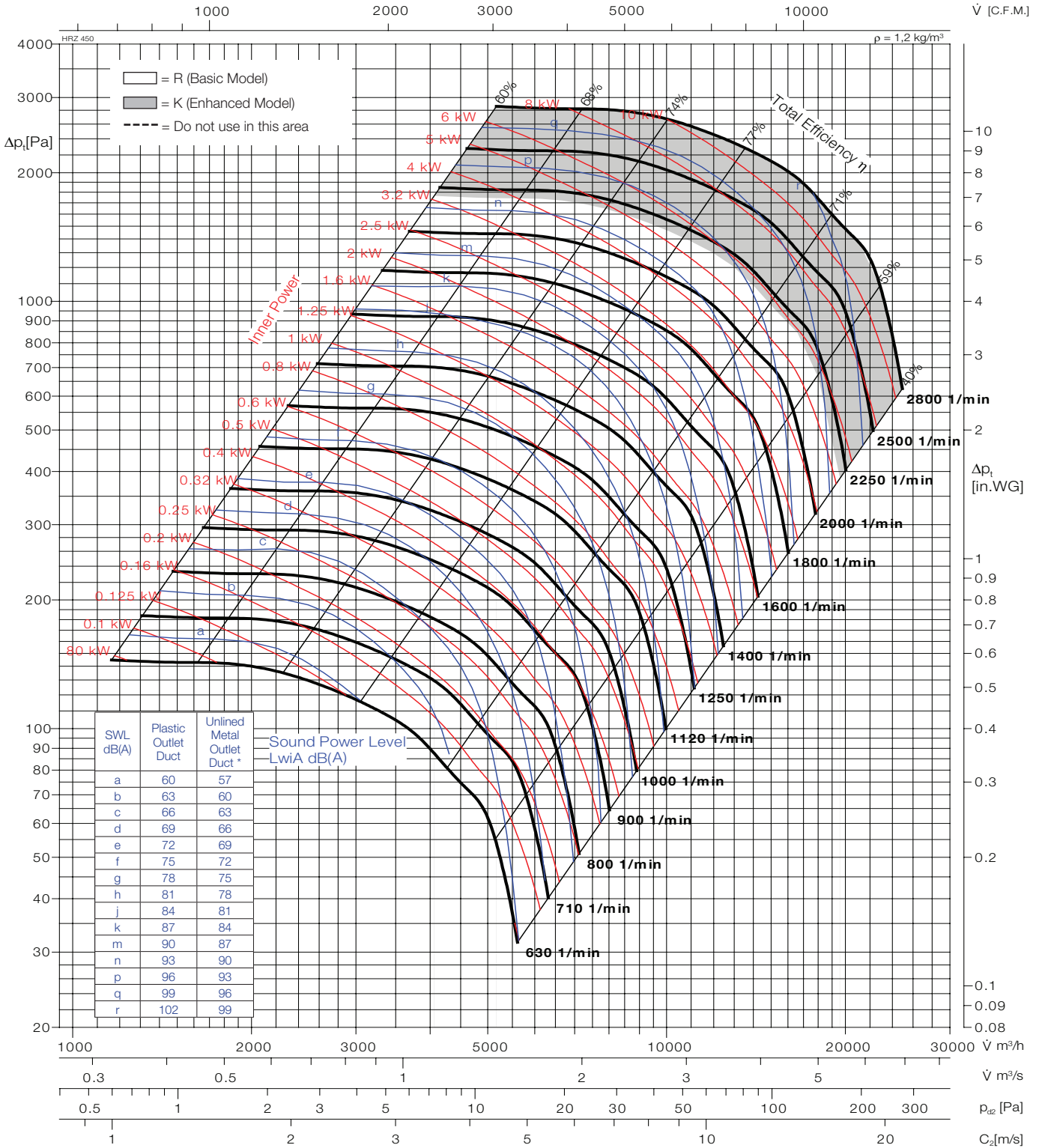

Typ	Art.Nr.	█ [kg]	Typ	Art.Nr.	█ [kg]
HRZ 05 450	541555	67,5			
HRZ 07 450	541557	82,5			

Wheel diameter	D = 454 mm
Number of blades	z = 16
Moment of inertia	J = 2,692 kgm²
Wheel weight	G = 18,7 kg
Speed limit	n_{max} = 2800 1/min

Performance Curve

HRZ 500



Fan test laboratory AMCA 210/99
Fig. 12, 140000 cmh Test Chamber.
Performance obtained is for installation type B-Free inlet, Ducted outlet.

Power rating (kW) does not include transmission losses, Performance ratings do not include the effects of appurtenances (accessories). The A-weighted sound ratings shown have been calculated per AMCA International Standard 301. Values shown are for LwiA sound power levels for installation Type B: free inlet, ducted outlet.

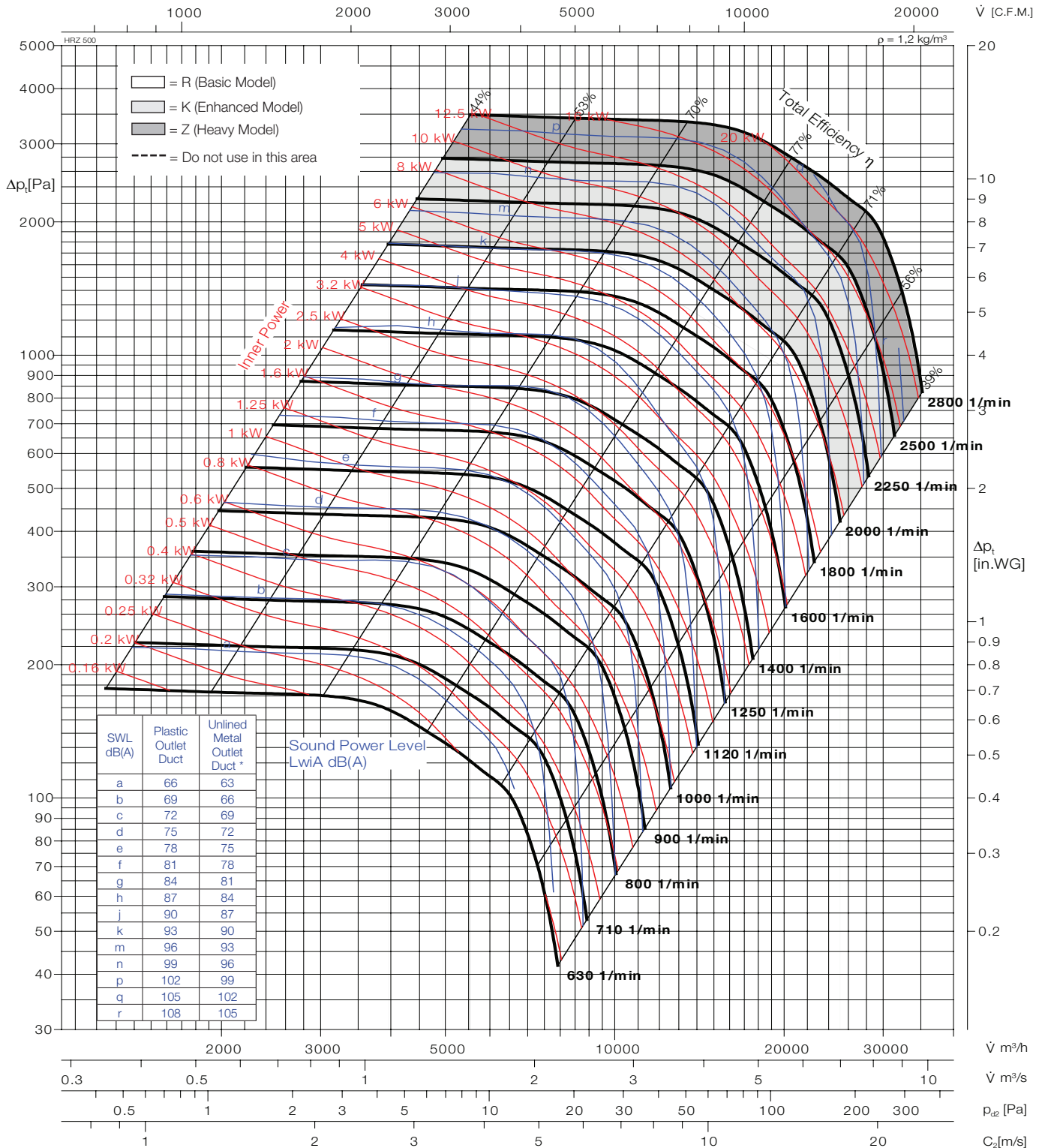

Typ	Art.Nr.	W [kg]	Typ	Art.Nr.	W [kg]
HRZ 05 500	541605	84,2			
HRZ 07 500	541607	104,2			

Wheel diameter	D = 510 mm
Number of blades	z = 16
Moment of inertia	J = 4,522 kgm²
Wheel weight	G = 24,9 kg
Speed limit	n_{max} = 2800 1/min

Performance Curve

HRZ 560



Fan test laboratory AMCA 210/99
Fig.12, 140000 cmh Test Chamber.
Performance obtained is for installation
type B-Free inlet, Ducted outlet.

Power rating (kW) does not include transmission losses, Performance ratings do not include the effects of apertures (accessories). The A-weighted sound ratings shown have been calculated per AMCA International Standard 301. Values shown are for inlet LwA sound power levels for installation Type B: free inlet, ducted outlet.

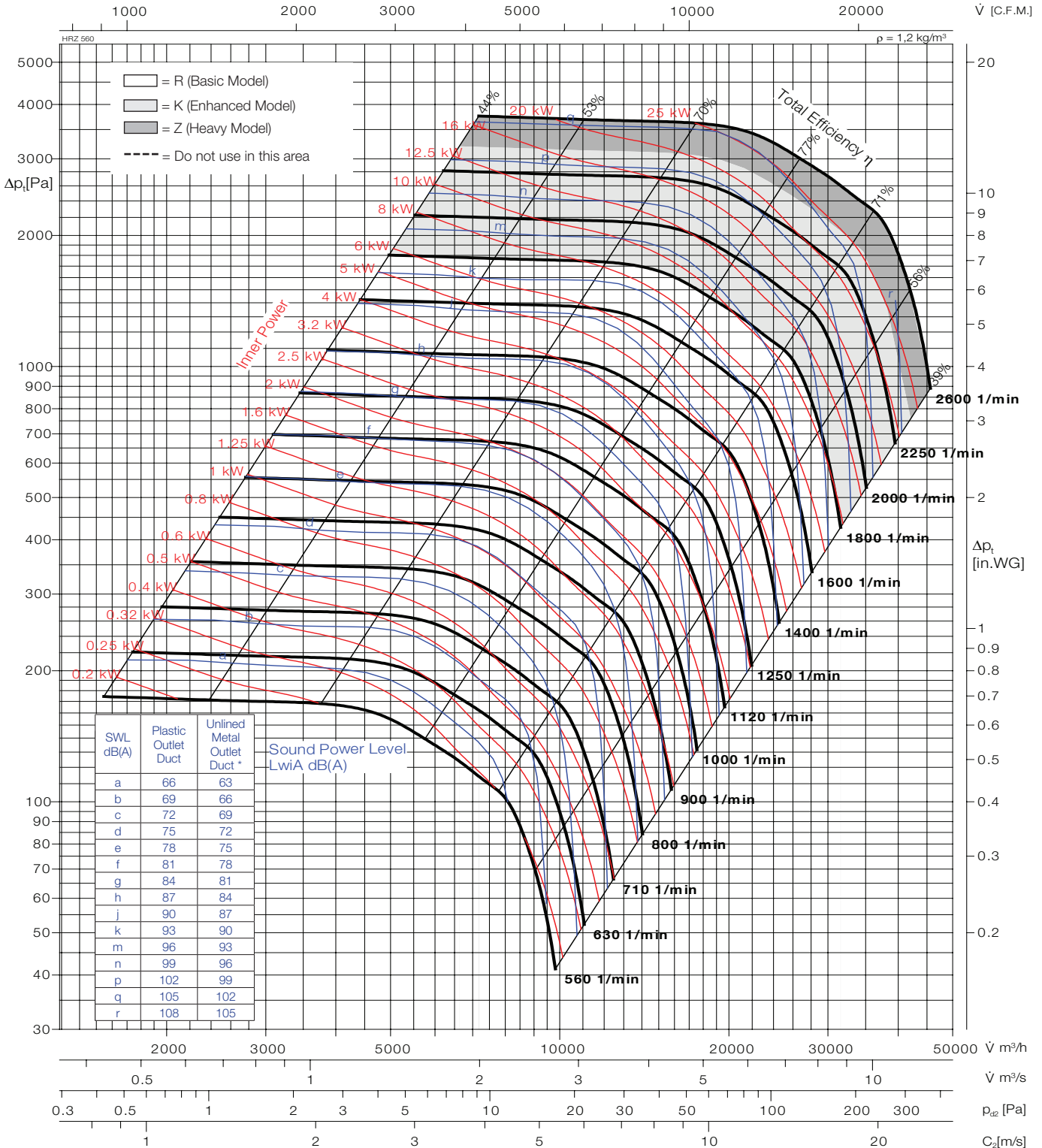

Typ	Art.Nr.	W [kg]	Typ	Art.Nr.	W [kg]
HRZ 05 560	541655	142			
HRZ 07 560	541657	171			

Wheel diameter	D = 570 mm
Number of blades	z = 16
Moment of inertia	J = 8,499 kgm²
Wheel weight	G = 37,4 kg
Speed limit	n_{max} = 2600 1/min

Performance Curve

HRZ 630



Fan test laboratory AMCA 210/99
Fig. 12, 140000 cmh Test Chamber.
Performance obtained is for installation type B-Free inlet, Ducted outlet.

Power rating (kW) does not include transmission losses, Performance ratings do not include the effects of appurtenances (accessories). The A-weighted sound ratings shown have been calculated per AMCA International Standard 301. Values shown are for inlet type B-Free inlet, Ducted outlet.

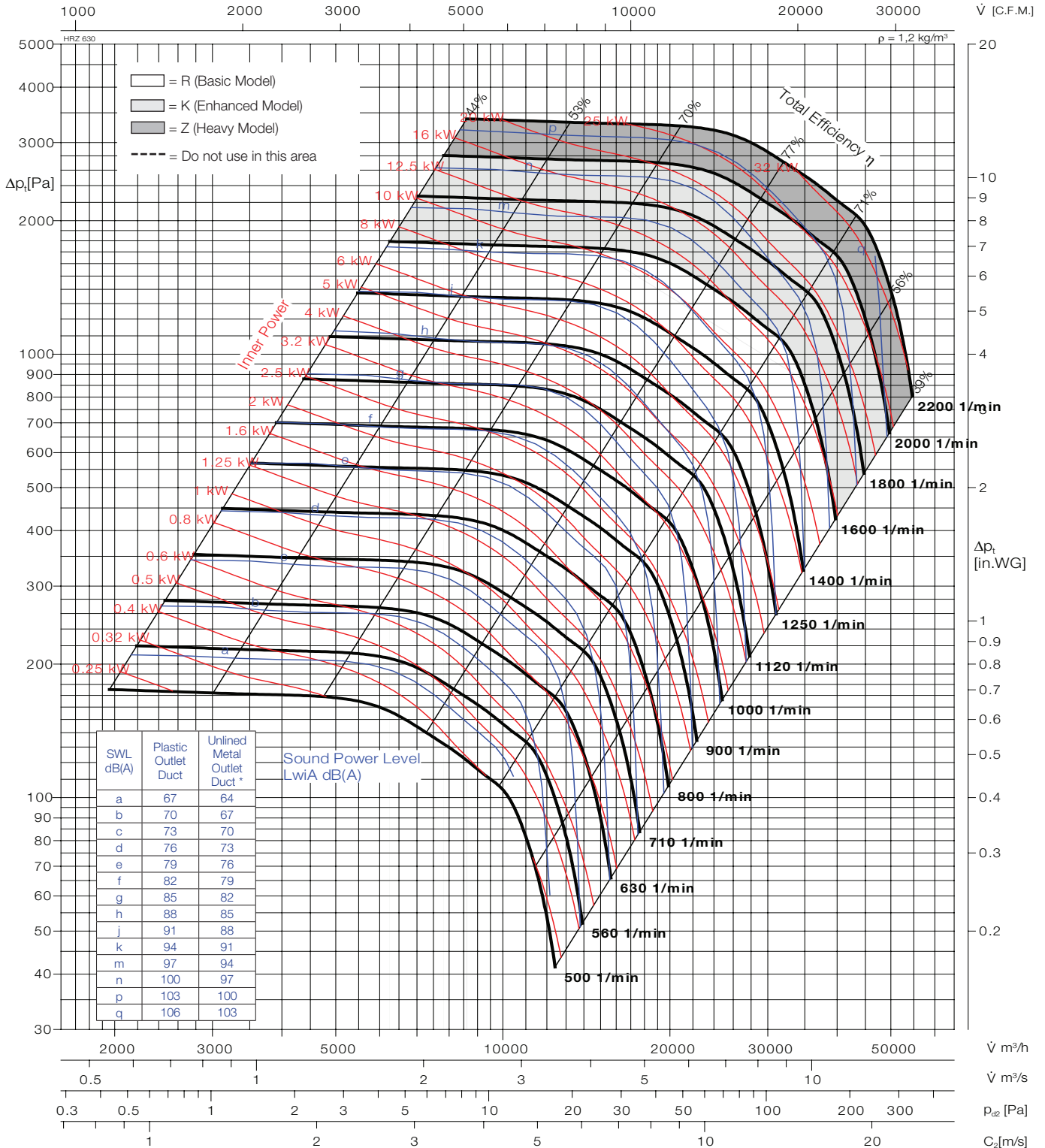

Typ	Art.Nr.	☼ [kg]	Typ	Art.Nr.	☼ [kg]
HRZ 05 630	541705	168			
HRZ 07 630	541707	197			

Wheel diameter	D = 640 mm
Number of blades	z = 16
Moment of inertia	J = 14,36 kgm²
Wheel weight	G = 50,2 kg
Speed limit	n_{max} = 2200 1/min

Performance Curve

HRZ 710



Fan test laboratory AMCA 210/99
Fig.12, 140000 cmh Test Chamber.
Performance obtained is for installation
type B-Free inlet, Ducted outlet.

Power rating (kW) does not include transmission losses, Performance ratings do not include the effects of appurtenances (accessories). The A-weighted sound ratings shown have been calculated per AMCA International Standard 301. Values shown are for inlet LwA sound power levels for installation Type B: free inlet, ducted outlet.

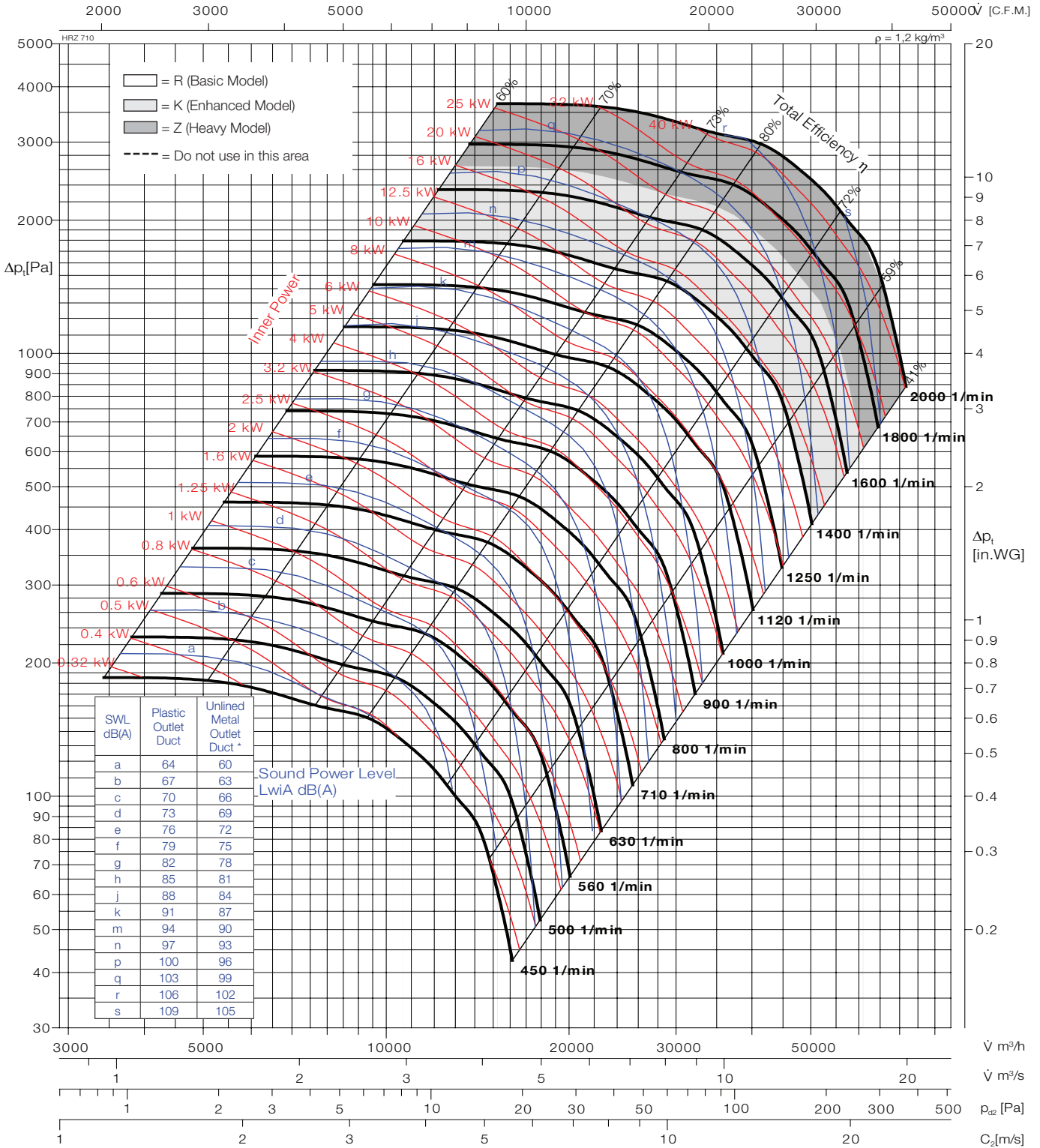

Typ	Art.Nr.	█ [kg]	Typ	Art.Nr.	█ [kg]
HRZ 05 710	541755	223			
HRZ 07 710	541757	271			

Wheel diameter	D = 720 mm
Number of blades	z = 16
Moment of inertia	J = 22,71 kgm²
Wheel weight	G = 62,9 kg
Speed limit	n_{max} = 2000 1/min

Performance Curve

HRZ 800



Fan test laboratory AMCA 210/99
Fig. 12, 140000 cmh Test Chamber.
Performance obtained is for installation type B-Free inlet, Ducted outlet.

Power rating (kW) does not include transmission losses, Performance ratings do not include the effects of appurtenances (accessories). The A-weighted sound ratings shown have been calculated per AMCA International Standard 301. Values shown are for unlined LwiA sound power levels for installation Type B: free inlet, ducted outlet.

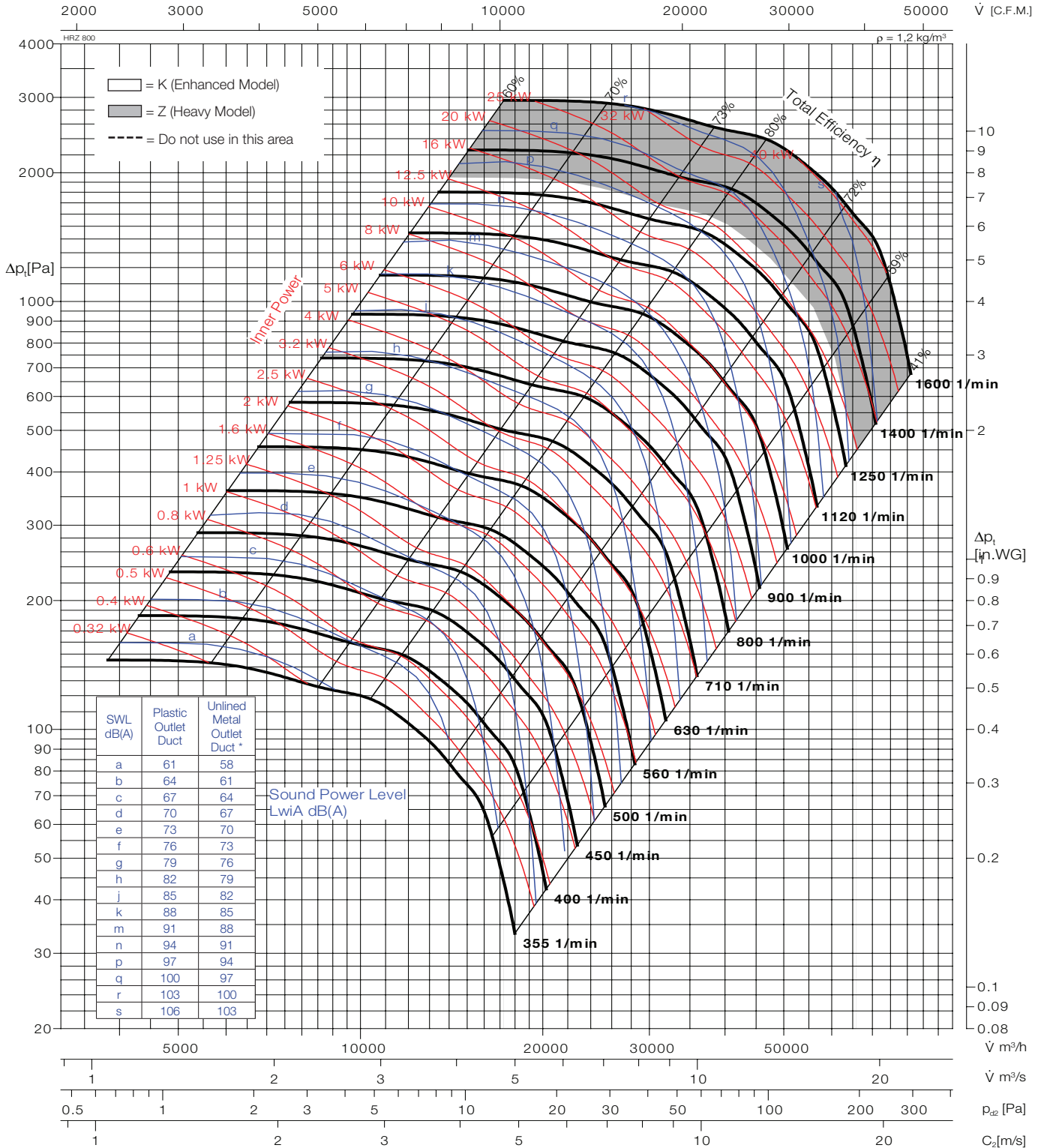

Typ	Art.Nr.	█ [kg]	Typ	Art.Nr.	█ [kg]
HRZ 07 800	541807	300			

Wheel diameter	D = 808 mm
Number of blades	z = 16
Moment of inertia	J = 36,78 kgm²
Wheel weight	G = 80,8 kg
Speed limit	n_{max} = 1600 1/min

Performance Curve

HRZ 900



Fan test laboratory AMCA 210/99
Fig.12, 140000 cmh Test Chamber.
Performance obtained is for installation type B-Free inlet, Ducted outlet.

Power rating (kW) does not include transmission losses, Performance ratings do not include the effects of appurtenances (accessories). The A-weighted sound shown have been calculated per AMCA International Standard 301. Values shown are for inlet LwIA sound power levels for installation Type B: free inlet, ducted outlet.

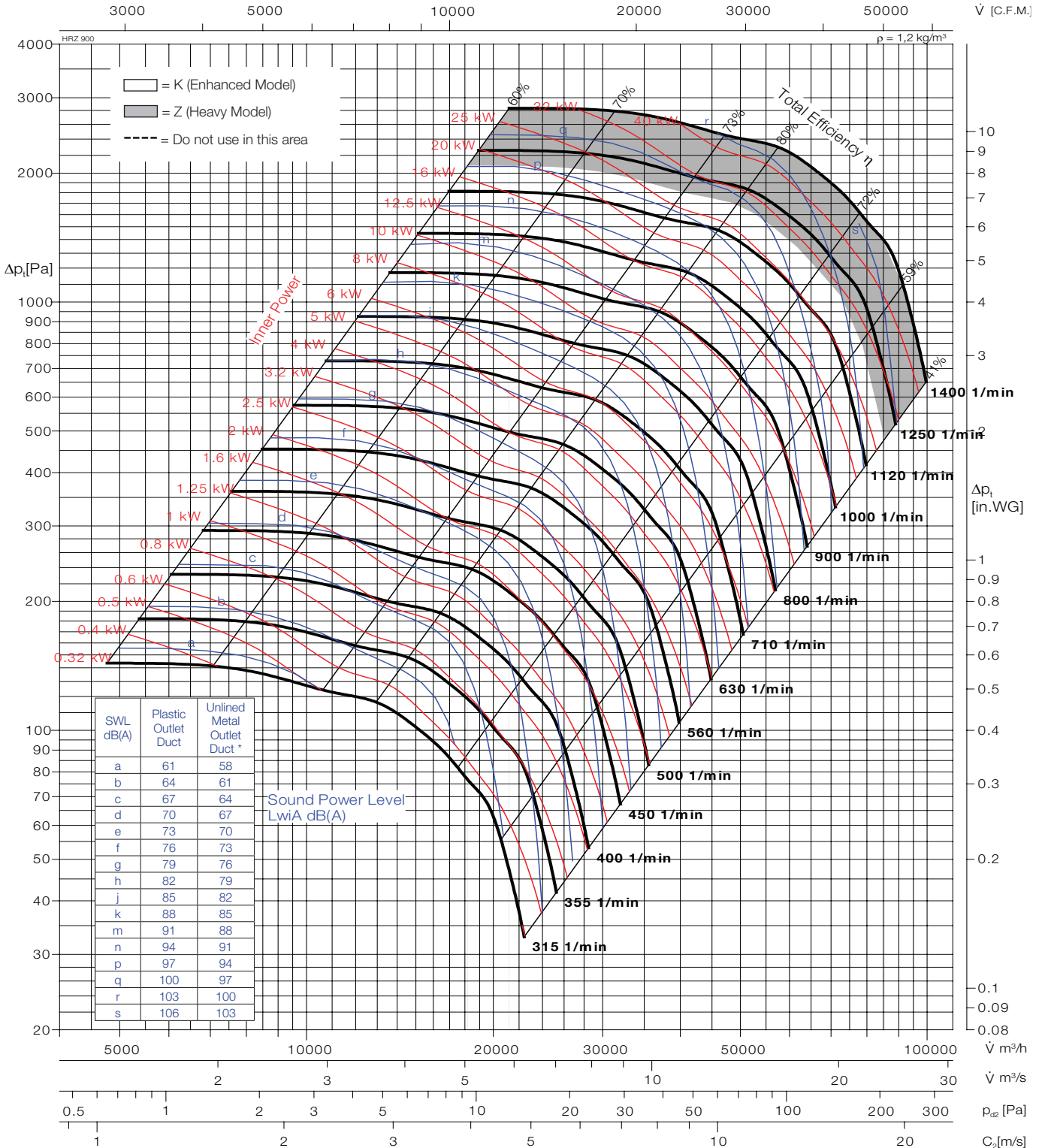

Typ	Art.Nr.	█ [kg]	Typ	Art.Nr.	█ [kg]
HRZ 07 900	541857	481,5			

Wheel diameter	D = 905 mm
Number of blades	z = 16
Moment of inertia	J = 63,69 kgm²
Wheel weight	G = 111 kg
Speed limit	n_{max} = 1400 1/min

Performance Curve

HRZ 1000



Fan test laboratory AMCA 210/99
Fig. 12, 140000 cmh Test Chamber.
Performance obtained is for installation type B-Free inlet, Ducted outlet.

Power rating (kW) does not include transmission losses, Performance ratings do not include the effects of appurtenances (accessories). The A-weighted sound ratings shown have been calculated per AMCA International Standard 301. Values shown are for LwiA sound power levels for installation Type B: free inlet, ducted outlet.

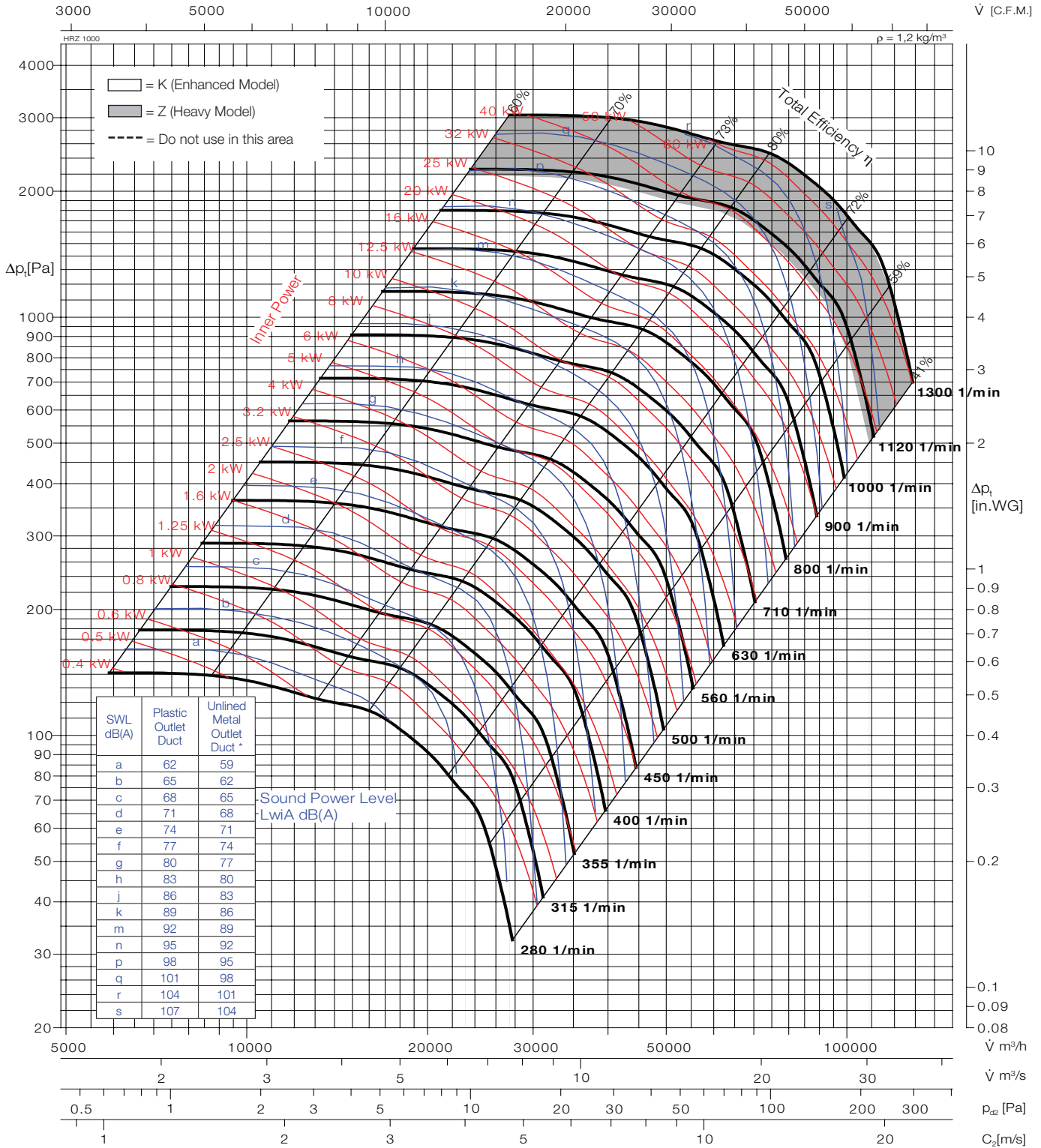

Typ	Art.Nr.	⚡ [kg]	Typ	Art.Nr.	⚡ [kg]
HRZ 07 1000	541907	530			

Wheel diameter	D = 1010 mm
Number of blades	z = 16
Moment of inertia	J = 101,5 kgm²
Wheel weight	G = 142 kg
Speed limit	n_{max} = 1300 1/min

Performance Curve

HRZ 1120



Fan test laboratory AMCA 210/99
Fig.12, 140000 cmh Test Chamber.
Performance obtained is for installation
type B-Free inlet, Ducted outlet.

Power rating (kW) does not include transmission losses, Performance ratings do not include the effects of appurtenances (accessories). The A-weighted sound ratings shown have been calculated per AMCA International Standard 301. Values shown are for Inlet LwA sound power levels for installation Type B: free inlet, ducted outlet.

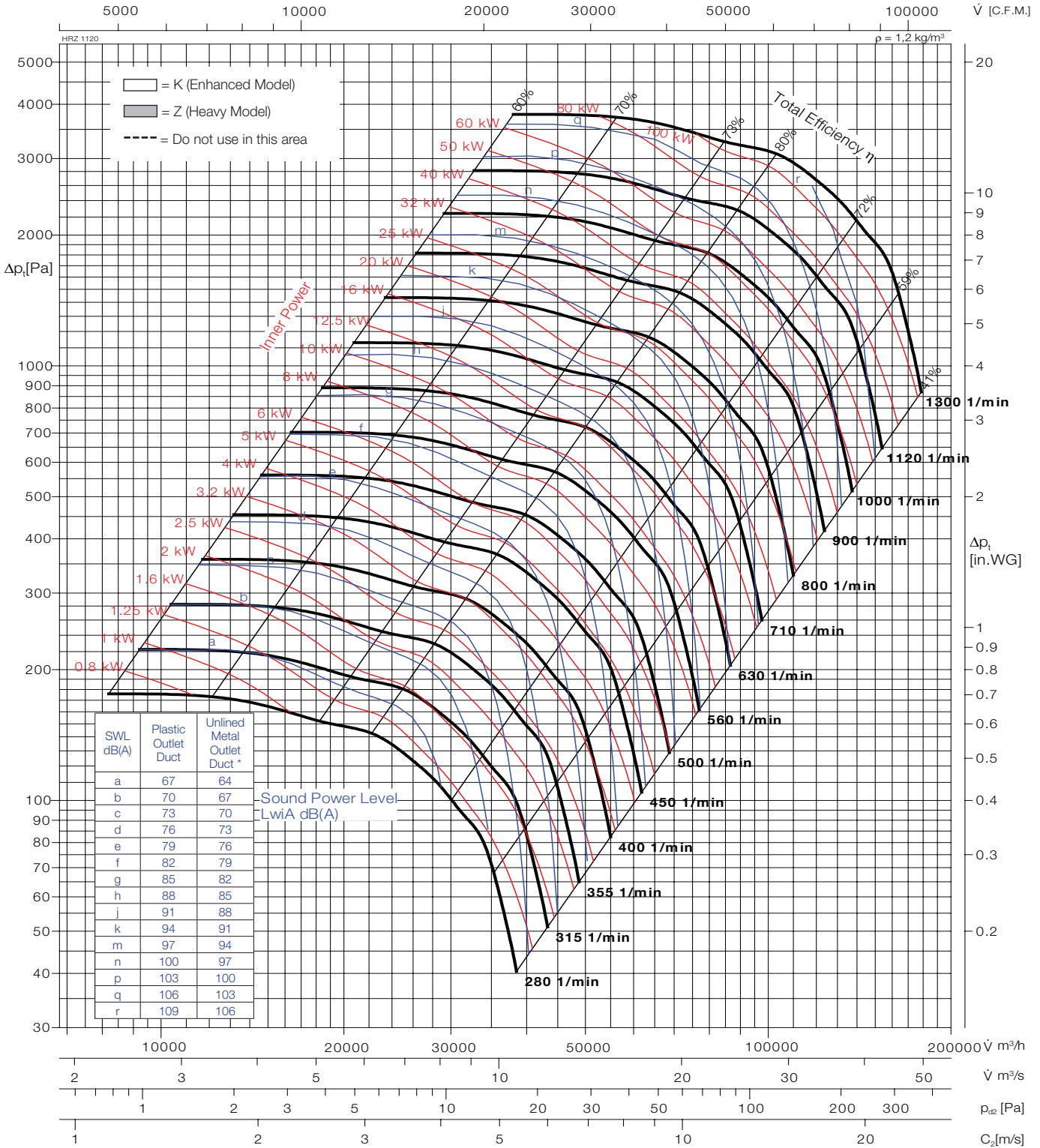

Typ	Art.Nr.	⚡ [kg]	Typ	Art.Nr.	⚡ [kg]
HRZ 07 1120	541917	-			

Wheel diameter	D = 1127 mm
Number of blades	z = 16
Moment of inertia	J = 162,4 kgm²
Wheel weight	G = 183 kg
Speed limit	n_{max} = 1300 1/min

Performance Curve

HRZ 1250



Fan test laboratory AMCA 210/99
Fig.12, 140000 cmh Test Chamber.
Performance obtained is for installation
type B-Free inlet, Ducted outlet.

Power rating (kW) does not include transmission losses, Performance ratings do not include the effects of appurtenances (accessories). The A-weighted sound ratings shown have been calculated per AMCA International Standard 301. Values shown are for LwiA sound power levels for installation Type B: free inlet, ducted outlet.

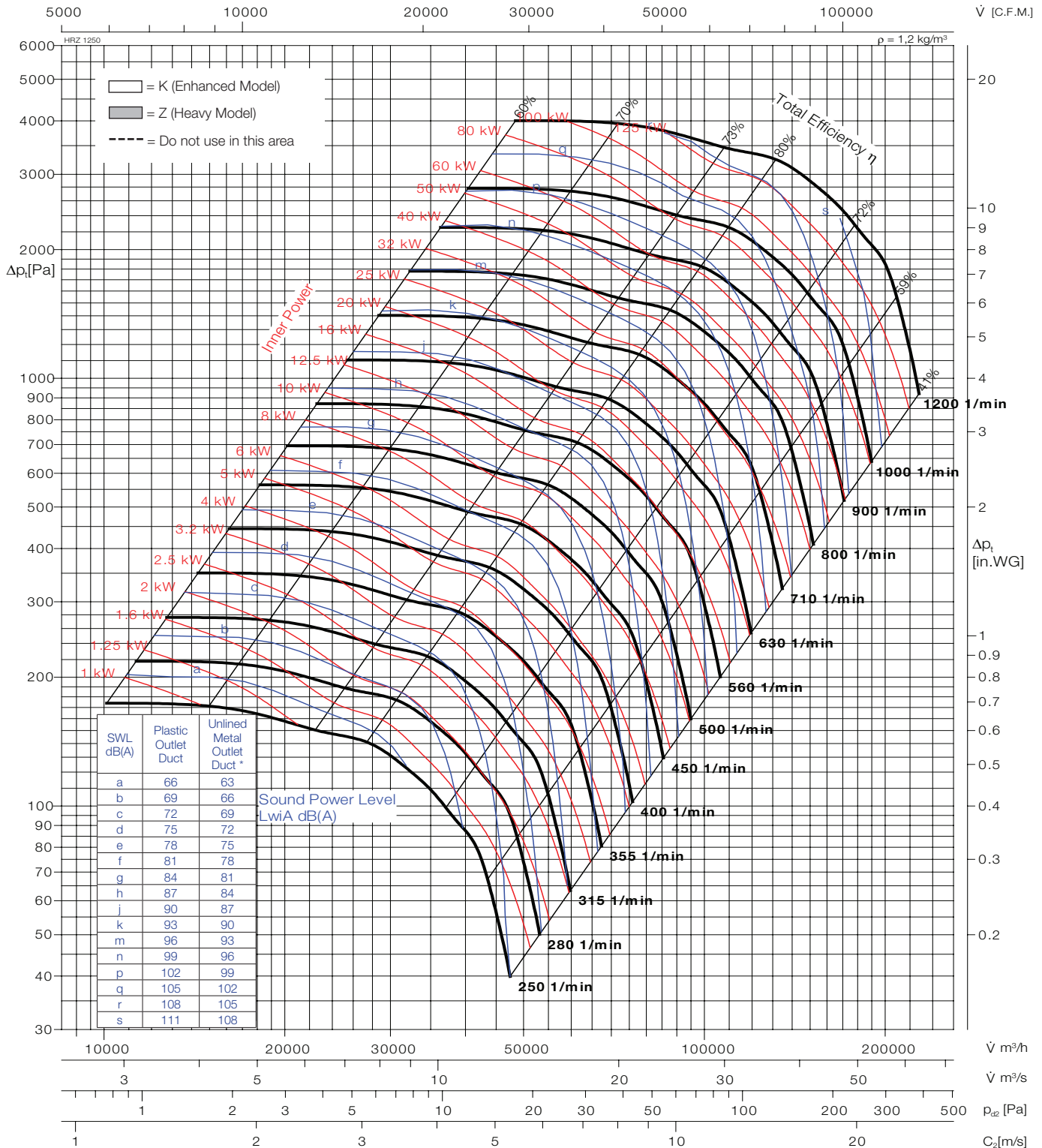

Typ	Art.Nr.	█ [kg]	Typ	Art.Nr.	█ [kg]
HRZ 07 1250	541927	-			

Wheel diameter	D = 1255 mm
Number of blades	z = 16
Moment of inertia	J = 258,9 kgm ²
Wheel weight	G = 235 kg
Speed limit	n_{max} = 1200 1/min

Performance Curve

HRZ 1400



Fan test laboratory AMCA 210/99
Fig.12, 140000 cmh Test Chamber.
Performance obtained is for installation
type B-Free inlet, Ducted outlet.

Power rating (kW) does not include transmission losses, Performance ratings do not include the effects of aperturancs (accessories). The A-weighted sound ratings shown have been calculated per AMCA International Standard 301. Values shown are for inlet LwIA sound power levels for installation Type B: free inlet, ducted outlet.

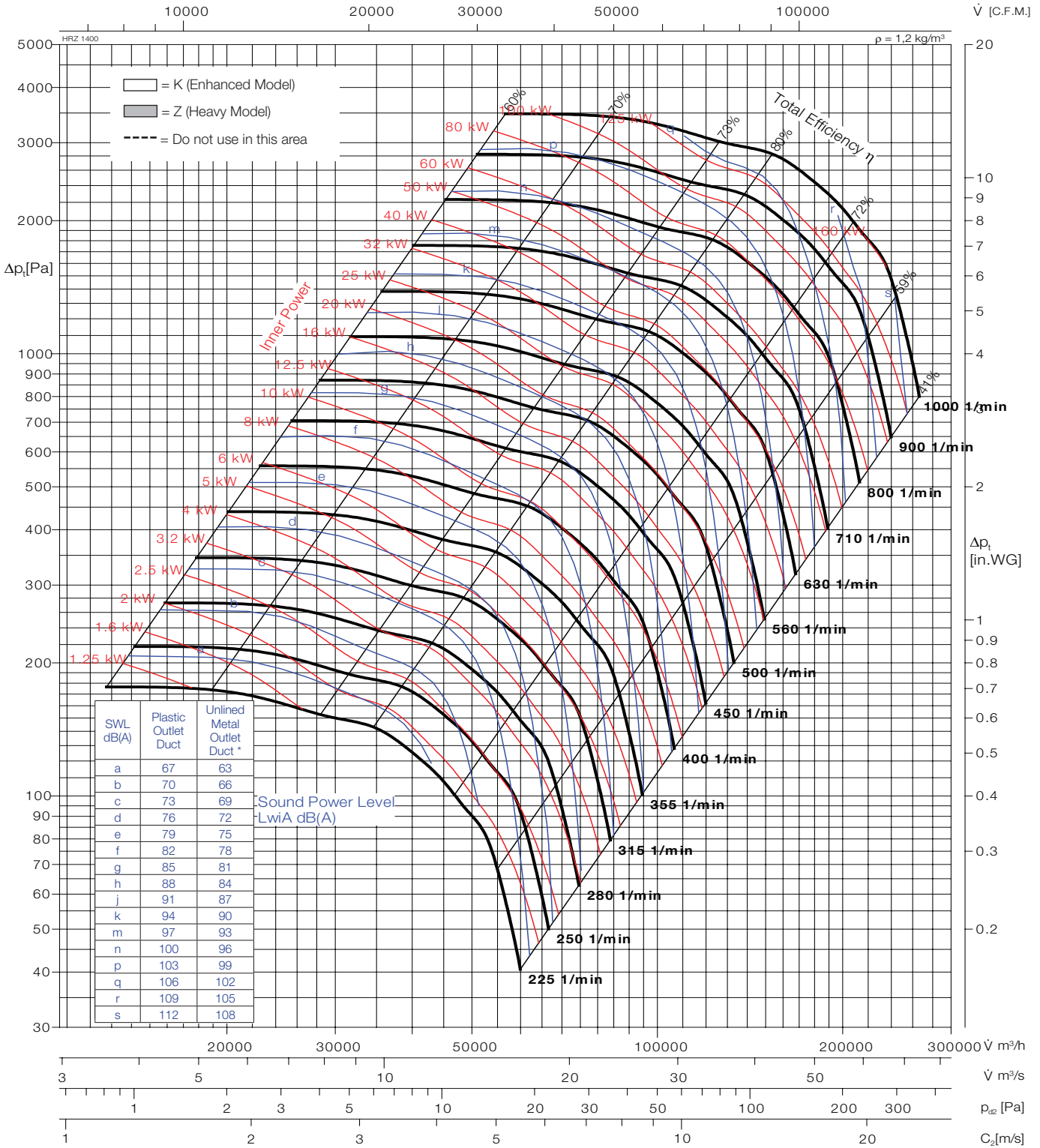

Typ	Art.Nr.	█ [kg]	Typ	Art.Nr.	█ [kg]
HRZ 07 1400	541947	-			

Wheel diameter	D = 1405 mm
Number of blades	z = 16
Moment of inertia	J = 417,3 kgm²
Wheel weight	G = 302 kg
Speed limit	n_{max} = 1000 1/min

Performance Curve

HRZ 1600



Fan test laboratory AMCA 210/99
Fig.12, 140000 cmh Test Chamber.
Performance obtained is for installation
type B-Free inlet, Ducted outlet.

Power rating (kW) does not include transmission losses, Performance ratings do not
include the effects of appurtenances (accessories). The A-weighted sound ratings shown
have been calculated per AMCA International Standard 301. Values shown are for
LwiA sound power levels for installation Type B: free inlet, ducted outlet.

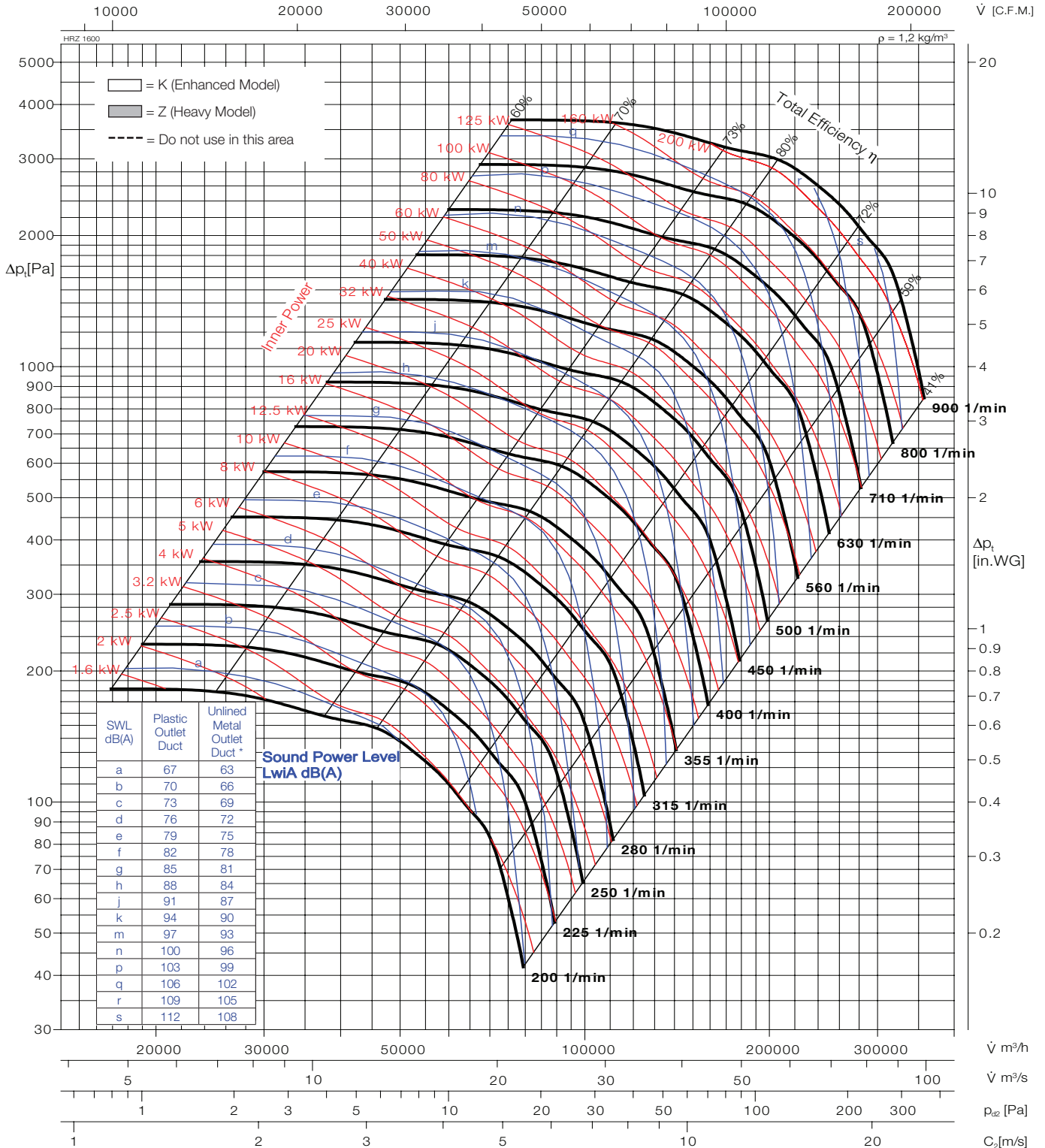

Typ	Art.Nr.	⚡ [kg]	Typ	Art.Nr.	⚡ [kg]
HRZ 07 1600	541957	-			

Wheel diameter	D = 1605 mm
Number of blades	z = 16
Moment of inertia	J = 716,6 kgm²
Wheel weight	G = 397 kg
Speed limit	n_{max} = 900 1/min

Dimensions

HRZ



HRZ 03

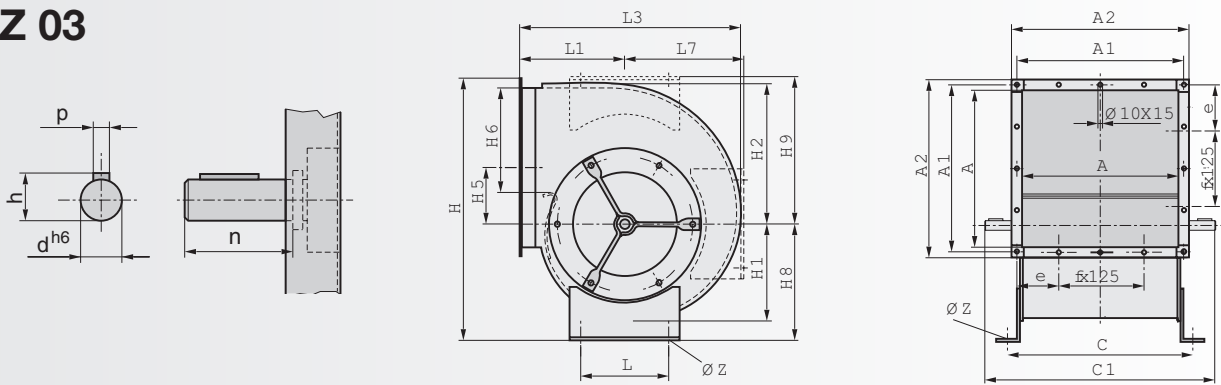

Size	A	A1	A2	C	C1	d	e	f	H	H1	H2	H5
-	[mm]	[mm]	[mm]	[mm]	[mm]	[mm]	[mm]	[mm]	[mm]	[mm]	[mm]	[mm]
315	404	434	460	434	565	25	150,5	50	635	241	350	138
355	453	483	509	494	655	30	50,5	60	692	271	393	156
400	507	537	563	544	710	30	75,5	60	768	304	441	180
450	569	599	625	604	780	35	105,5	65	879	341	495	204

Size	H6	H8	H9	h	L	L1	L3	L7	n	p	ØZ
-	[mm]	[mm]	[mm]	[mm]	[mm]	[mm]	[mm]	[mm]	[mm]	[mm]	[mm]
315	246	268	377	28	280	251	540	290	55	8	13
355	279	281	418	33	355	276	601	327	69	8	13
400	315	309	469	33	355	306	670	366	74	8	13
450	354	346	528	38	450	337	746	415	76	10	13

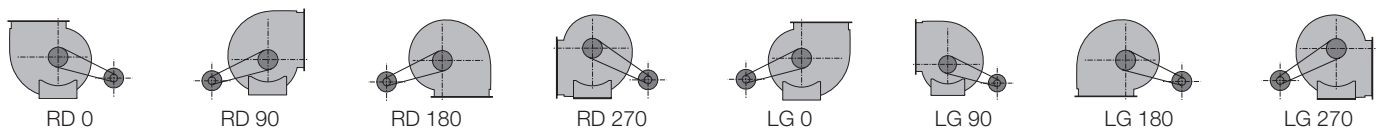

RD = clockwise

LG = anti-clockwise

The direction of rotation is defined by vue on the side of drive.

We reserve the right to alter measurements without notice in case of technical improvements.

Dimensions

HRZ

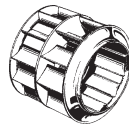

HRZ 05

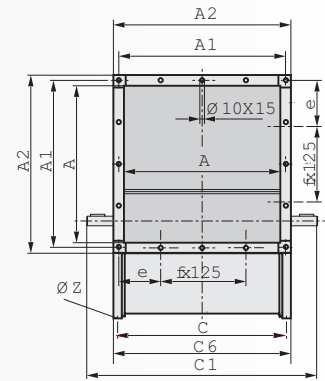
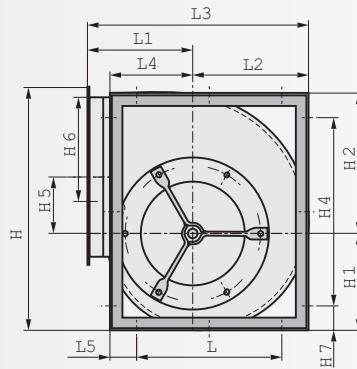
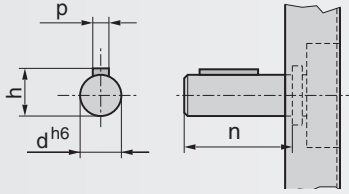

Size	A	A1	A2	C	C1	C6	d	e	f	H	H1	H2	H4
-	[mm]	[mm]	[mm]	[mm]	[mm]	[mm]	[mm]	[mm]	[mm]	[mm]	[mm]	[mm]	[mm]
315	404	434	460	434	640	421	25	217	-	578	235	343	280
355	453	493	509	493	700	464	30	241,5	-	655	266	389	355
400	507	547	563	547	760	533	30	168,5	100	736	301	436	355
450	569	599	625	609	845	649	35	199,5	100	827	336	491	530
500	638	668	694	678	915	718	35	209	125	918	375	543	530
560	715	745	771	765	1000	815	40	247,5	125	1030	420	610	530
630	801	831	857	851	1090	901	45	265,5	150	1157	472	685	530

Size	H5	H6	H7	h	L	L1	L2	L3	L4	L5	n	p	ØZ
-	[mm]	[mm]	[mm]	[mm]	[mm]	[mm]	[mm]	[mm]	[mm]	[mm]	[mm]	[mm]	[mm]
315	138	202	149	28	280	236	282	518	198	100	88	8	13
355	156	227	150	33	355	261	317	578	231	97	84	8	13
400	178	254	190	33	355	290	361	651	252	129	86	8	13
450	202	285	149	38	530	322	404	726	277	76	98	10	13
500	219	319	194	38	530	352	448	800	302	110	98	10	13
560	245	358	250	43	530	390	503	893	342	158	92	12	13
630	278	400	314	48	530	434	565	999	381	208	95	14	13

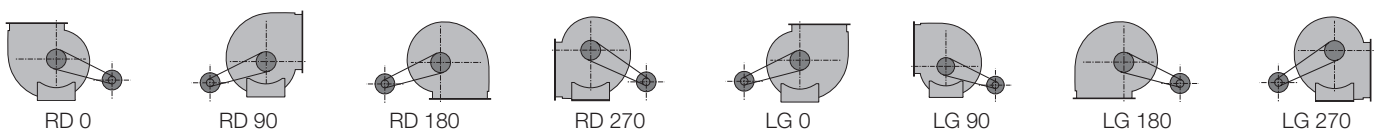

RD = clockwise

LG = anti-clockwise

The direction of rotation is defined by view on the side of drive.

We reserve the right to alter measurements without notice in case of technical improvements.

Dimensions

HRZ

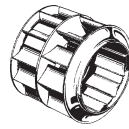

HRZ 07

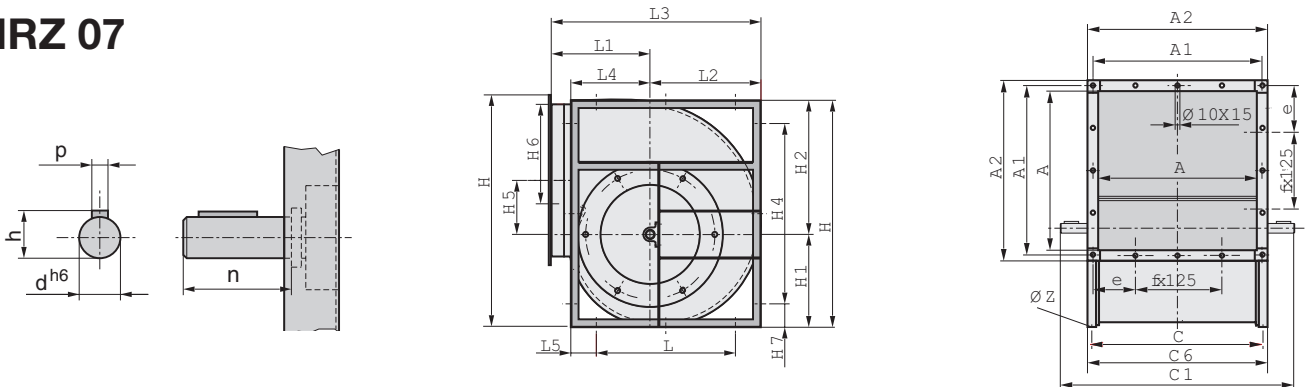

Size	A	A1	A2	C	C1	C6	d	e	f	H	H1	H2	H4
-	[mm]	[mm]	[mm]	[mm]	[mm]	[mm]	[mm]	[mm]	[mm]	[mm]	[mm]	[mm]	[mm]
710	898	928	954	948	1290	998	60	264	200	1303	527	765	630
800	1007	1037	1063	1057	1450	1107	60	268,5	250	1468	595	862	710
900	1130	1160	1186	1180	1570	1250	60	280	300	1648	666	971	800
1000	1267	1297	1323	1317	1700	1387	60	298,5	350	1810	733	1066	900
1120	1416	1446	1472	1466	1860	1536	70	-	-	2027	821	1206	1000
1250	1578	1608	1634	1628	2020	1698	70	-	-	2263	916	1347	1120
1400	1744	1774	1800	1794	2190	1884	70	-	-	2534	1026	1328	1250
1600	2020	2050	2076	2070	2460	2160	80	-	-	2896	1173	1723	1400

Size	H5	H6	H7	h	L	L1	L2	L3	L4	L5	n	p	ØZ
-	[mm]	[mm]	[mm]	[mm]	[mm]	[mm]	[mm]	[mm]	[mm]	[mm]	[mm]	[mm]	[mm]
710	316	-	337	64,4	630	485	636	1121	422	214	146	18	17
800	359	-	379	64,4	710	535	715	1250	466	236	172	18	17
900	406	-	424	64,4	800	604	804	1408	515	260	160	18	17
1000	433	-	455	64,4	900	657	884	1541	578	281	157	18	17
1120	498	-	514	74,9	1000	739	997	1736	647	322	-	20	17
1250	556	-	572	74,9	1120	837	1112	1949	712	352	-	20	17
1400	623	-	642	74,9	1250	938	1246	2184	809	402	-	20	17
1600	712	-	748	85,4	1400	1072	1424	2496	925	474	-	22	17

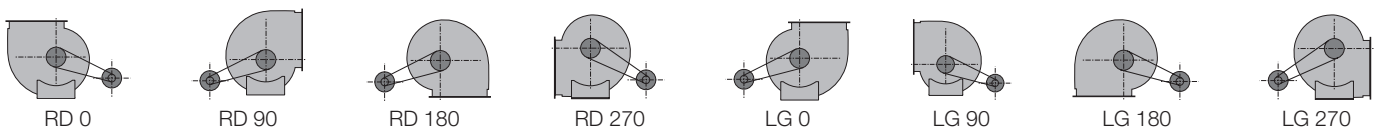

RD = clockwise

LG = anti-clockwise

The direction of rotation is defined by vue on the side of drive.

We reserve the right to alter measurements without notice in case of technical improvements.

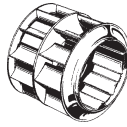

HRZ 05

with external bearings

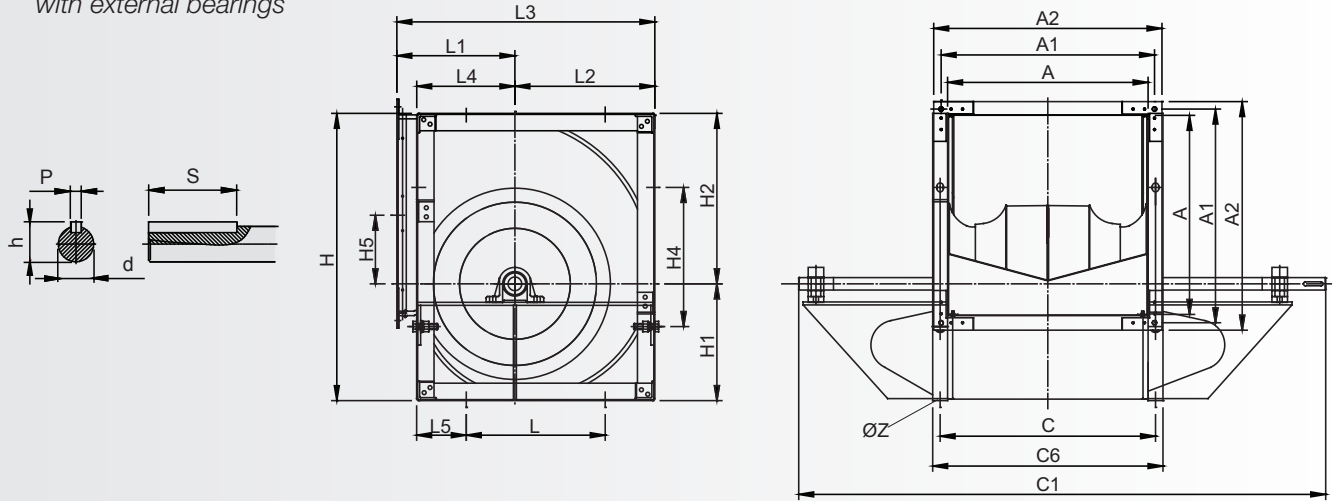

Size	A	A1	A2	C	C1	C6	d	H	H1	H2	H4
-	[mm]	[mm]	[mm]	[mm]	[mm]	[mm]	[mm]	[mm]	[mm]	[mm]	[mm]
315	404	434	460	434	1062	421	25	578	235	343	280
355	453	493	509	493	1157	464	30	655	266	389	355
400	507	547	563	547	1263	533	30	736	301	436	355
450	569	599	625	609	1382	649	35	827	336	491	530
500	638	668	694	678	1500	718	35	918	375	543	530
560	715	745	771	765	1643	815	40	1030	420	610	530
630	801	831	857	851	1810	901	45	1157	472	685	530

Size	H5	h	L	L1	L2	L3	L4	L5	n	p	ØZ
-	[mm]	[mm]	[mm]	[mm]	[mm]	[mm]	[mm]	[mm]	[mm]	[mm]	[mm]
315	138	28	280	236	282	518	198	100	88	8	13
355	156	33	355	261	317	578	231	97	84	8	13
400	178	33	355	290	361	651	252	129	86	8	13
450	202	38	530	322	404	726	277	76	98	10	13
500	219	38	530	352	448	800	302	110	98	10	13
560	245	43	530	390	503	893	342	158	92	12	13
630	278	48	530	434	565	999	381	208	95	14	13

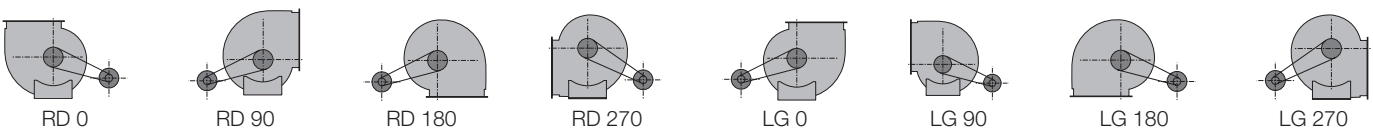

RD = clockwise

LG = anti-clockwise

The direction of rotation is defined by vue on the side of drive.

We reserve the right to alter measurements without notice in case of technical improvements.

Dimensions

HRZ

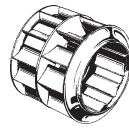

HRZ 07

with external bearings

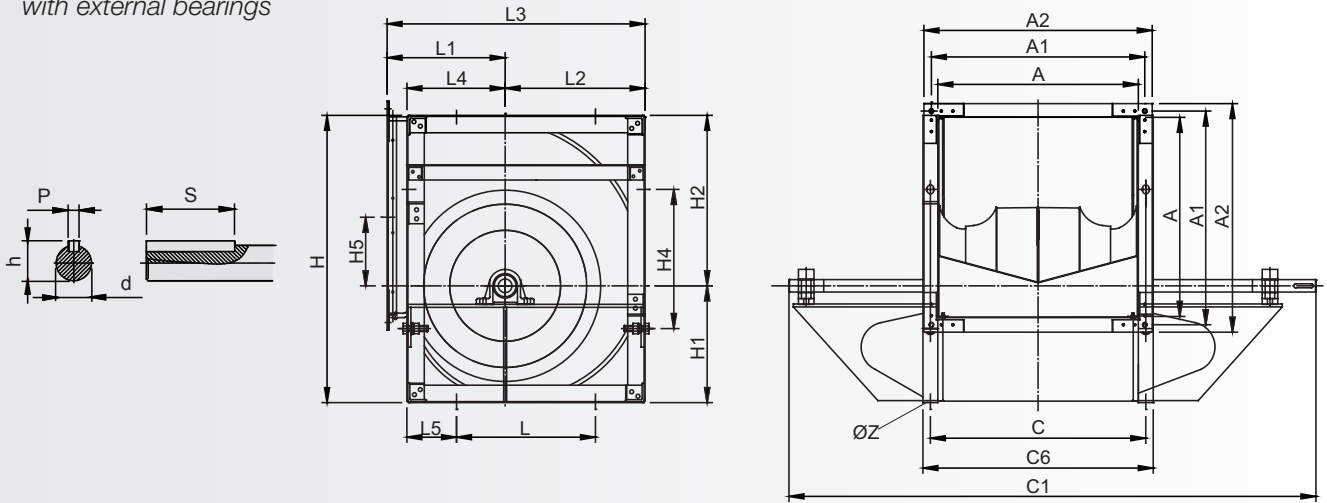

Size	A	A1	A2	C	C1	C6	d	H	H1	H2	H4
-	[mm]	[mm]	[mm]	[mm]	[mm]	[mm]	[mm]	[mm]	[mm]	[mm]	[mm]
710	898	928	954	948	2000	998	60	1303	527	765	630
800	1007	1037	1063	1057	2101	1107	60	1468	595	862	710
900	1130	1160	1186	1180	2368	1250	60	1648	666	971	800
1000	1267	1297	1323	1317	2629	1387	60	1810	733	1066	900
1120	1416	1446	1472	1466	2721	1536	70	2027	821	1206	1000
1250	1578	1608	1634	1628	3021	1698	70	2263	916	1347	1120
1400	1744	1774	1800	1794	3366	1884	70	2534	1026	1328	1250
1600	2020	2050	2076	2070	3854	2160	80	2896	1173	1723	1400

Size	H5	h	L	L1	L2	L3	L4	L5	n	p	ØZ
-	[mm]	[mm]	[mm]	[mm]	[mm]	[mm]	[mm]	[mm]	[mm]	[mm]	[mm]
710	316	64,4	630	485	636	1121	422	214	146	18	17
800	359	64,4	710	535	715	1250	466	236	172	18	17
900	406	64,4	800	604	804	1408	515	260	160	18	17
1000	433	64,4	900	657	884	1541	578	281	157	18	17
1120	498	74,9	1000	739	997	1736	647	322	-	20	17
1250	556	74,9	1120	837	1112	1949	712	352	-	20	17
1400	623	74,9	1250	938	1246	2184	809	402	-	20	17
1600	712	85,4	1400	1072	1424	2496	925	474	-	22	17

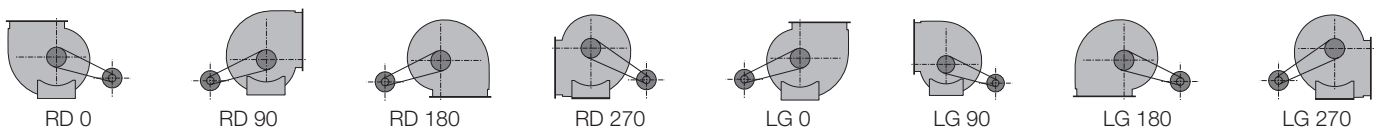

RD = clockwise

LG = anti-clockwise

The direction of rotation is defined by vue on the side of drive.

We reserve the right to alter measurements without notice in case of technical improvements.

Dimensions

KB / HRZ

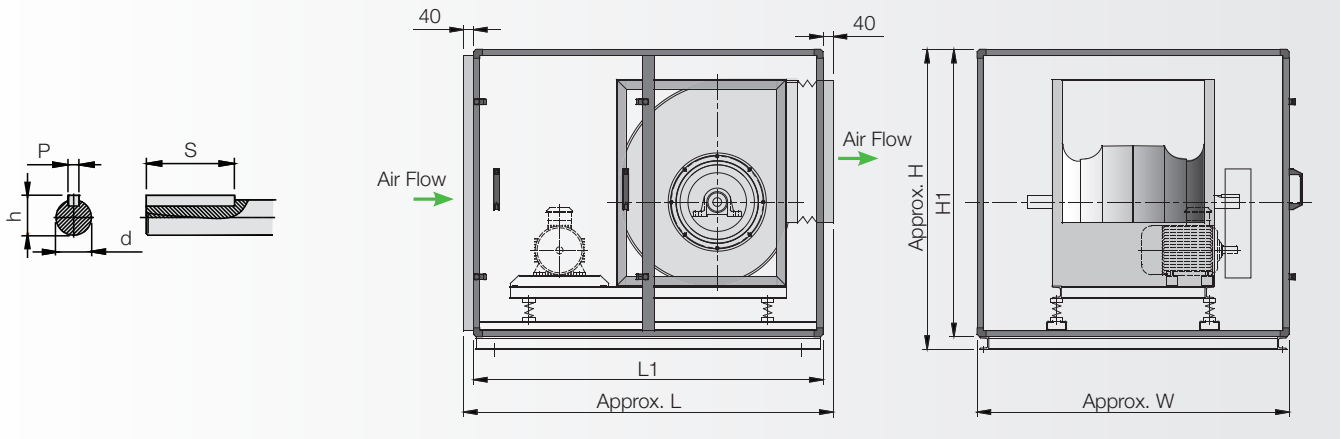
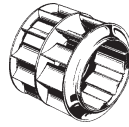

Model KB / HRZ	d [mm]	h [mm]	H [mm]	H1 [mm]	Max. L [mm]	Max. L1 [mm]	P [mm]	S [mm]	W [mm]	W1 [mm]
315	25	28	870	820	1120	1040	8	50	860	-
355	30	33	950	900	1280	1200	8	50	970	-
400	30	33	1040	990	1350	1270	8	50	1070	-
450	35	38	1140	1090	1460	1380	10	70	1180	-
500	35	38	1240	1190	1530	1450	10	70	1310	-
560	40	43	1430	1350	1740	1660	12	70	1430	-
630	45	48	1570	1490	1890	1810	14	70	1590	-
710	60	64,4	1730	1650	2020	1940	18	100	1770	-
800	60	64,4	1910	1830	2140	2060	18	100	1970	-
900	60	64,4	2250	2150	2300	2220	18	100	2080	-
1000	60	64,4	2430	2330	2540	2460	18	100	2140	-
1120	70	74,9	2620	2500	2730	2650	20	150	2800	-
1250	70	74,9	2870	2750	2930	2850	20	150	3000	-
1400	70	74,9	3070	2950	3130	3050	20	150	3300	-
1600	80	85,4	3320	3200	3330	3250	22	200	3700	-

NB: Dimension above for the fan with LG / RD 90 Deg and 270 Deg.
Pressure loss on cabinet not included.

Dimensions

KBH / HRZ

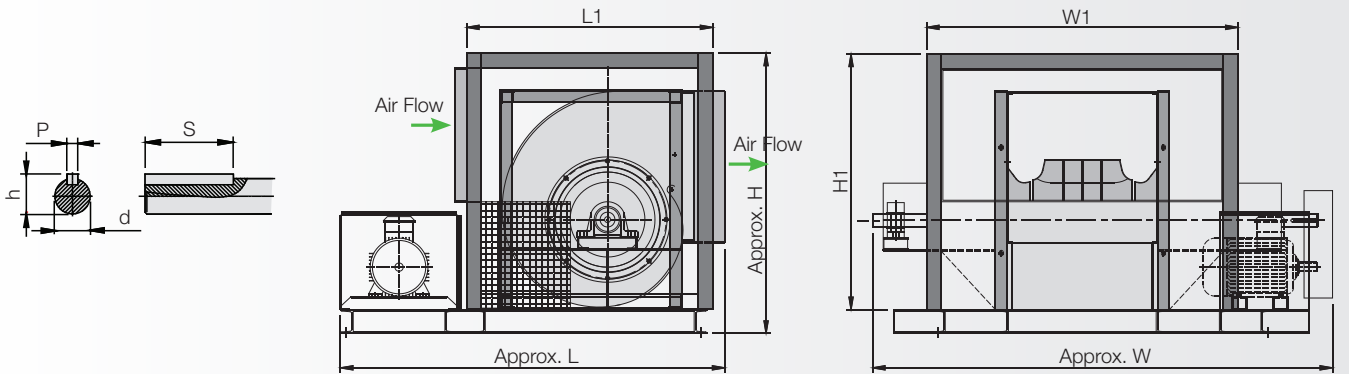
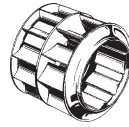

Model KBH / HRZ	d [mm]	H [mm]	H1 [mm]	L [mm]	L1 [mm]	P [mm]	S [mm]	h [mm]	W [mm]	W1 [mm]
315	40	790	740	1170	700	12	70	43,3	1320	830
355	45	880	800	1230	760	14	70	48,8	1430	940
400	45	943	860	1296	830	14	70	48,8	1524	1050
450	50	1060	980	1370	900	14	90	53,8	1730	1150
500	50	1130	1050	1450	980	14	90	53,8	1850	1270
560	60	1320	1240	1680	1080	18	100	64,4	2010	1480
630	60	1440	1360	1870	1270	18	100	64,4	2160	1630
710	70	1600	1500	2000	1400	20	150	74,9	2490	1800
800	70	1770	1670	2130	1530	20	150	74,9	2690	2000
900	70	1950	1850	2280	1680	20	150	74,9	2930	2250
1000	80	2100	2000	2410	1810	22	200	85,4	3170	2480
1120	80	2150	2033	2740	2000	22	200	85,4	3400	3100
1250	80	2400	2285	2940	2200	22	200	85,4	3630	3330
1400	95	2550	2445	3240	2400	25	200	100,4	3900	3600
1600	95	2750	2616	3440	2600	25	200	100,4	4130	3830

NB: Dimension above for the fan with LG / RD 90 Deg and 270 Deg.
Pressure loss on cabinet not included.

For smoke spill applications the model of fan used is type HRZ / HRZ-B (backward curve impeller). Impellers and inlet cones are manufactured from mild steel and suitably reinforced for high temperatures applications.

We reserve the right to alter measurements without notice in case of technical improvements.

Dimensions

KBHS / HRZ

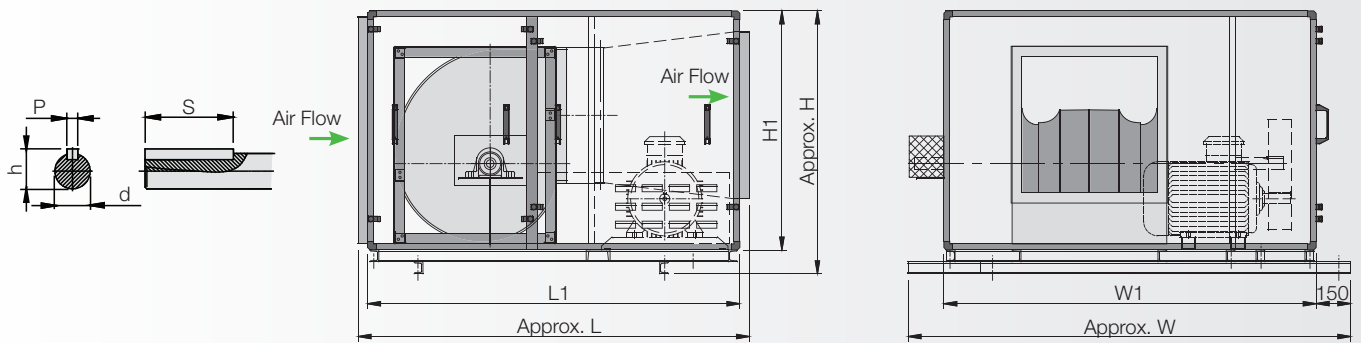
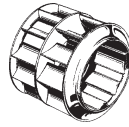

Model KBHS / HRZ	d [mm]	h [mm]	H [mm]	H1 [mm]	L [mm]	L1 [mm]	P [mm]	S [mm]	W [mm]	W1 [mm]
315	40	43,3	850	750	1330	1350	12	70	1480	1180
355	45	48,8	900	800	1430	1450	14	70	1590	1290
400	45	48,8	1000	900	1480	1500	14	70	1700	1400
450	50	53,8	1100	1000	1580	1600	14	90	1800	1500
500	50	53,8	1200	1100	1680	1650	14	90	1920	1620
560	60	64,4	1410	1250	1880	1800	18	100	2130	1830
630	60	64,4	1510	1350	2080	2000	18	100	2280	1980
710	70	74,9	1660	1500	2230	2150	20	150	2450	2150
800	70	74,9	1860	1700	2330	2250	20	150	2650	2350
900	70	74,9	2050	1850	2480	2400	20	150	2900	2600
1000	80	85,4	2250	2050	2630	2550	22	200	3130	2830
1120	80	85,4	2600	2400	3030	2950	22	200	3400	3100
1250	80	85,4	3030	2830	3430	3350	22	200	3630	3330
1400	95	100,4	3550	3350	3930	3750	25	200	3900	3600
1600	95	100,4	4200	4000	4380	4300	25	200	4130	3830

NB: Dimension above for the fan with LG / RD 90 Deg and 270 Deg.

Pressure loss on cabinet not included.

For smoke spill applications the model of fan used is type HRZ (backward curve impeller). Impellers and inlet cones are manufactured from mild steel and suitably reinforced for high temperatures applications.

We reserve the right to alter measurements without notice in case of technical improvements.

Fan Laws - Proportional Laws

Here are some useful information and fan laws:

Speed change - constant size

- Volume flow \approx rotational speed

$$\frac{\dot{V}_2}{\dot{V}_1} = \frac{n_2}{n_1}$$

- Pressure (all) \approx (rotational speed)²

$$\frac{\Delta p_1}{\Delta p_2} = \left(\frac{n_1}{n_2}\right)^2 = \left(\frac{\dot{V}_1}{\dot{V}_2}\right)^2$$

- Power absorbed \approx (rotational speed)³

$$\frac{P_1}{P_2} = \left(\frac{n_1}{n_2}\right)^3 = \left(\frac{\dot{V}_1}{\dot{V}_2}\right)^3$$

Density change - constant speed - constant size

- Volume flow no change

$$\dot{V} = \text{constant}$$

- Pressure \approx Density

$$\frac{\Delta p_1}{\Delta p_2} = \frac{\rho_1}{\rho_2} = \frac{T_2}{T_1}$$

- Power absorbed \approx Density

$$\frac{P_1}{P_2} = \frac{\rho_1}{\rho_2} = \frac{T_2}{T_1}$$

Size change - constant speed (for geometrically similar fans only)

- Volume flow \approx (impeller Diameter)³

$$\frac{\dot{V}_2}{\dot{V}_1} = \left(\frac{D_2}{D_1}\right)^3$$

- Pressure \approx (impeller Diameter)²

$$\frac{\Delta p_1}{\Delta p_2} = \left(\frac{D_1}{D_2}\right)^2$$

- Power absorbed \approx (impeller Diameter)⁵

$$\frac{P_1}{P_2} = \left(\frac{D_1}{D_2}\right)^5$$

Pressure

- Dynamic Pressure [Pa]

$$p_d = \frac{\rho}{2} \cdot v^2$$

whereby:

- ρ = air density in [kg/m³]
- v = air velocity in [m/s]

- Total pressure

$$p_t = p_{st} + p_d$$

Absorbed power - calculation in duty point

$$P_L [\text{kW}] = \frac{\dot{V} [\text{m}^3/\text{s}] \cdot \Delta p_t [\text{Pa}]}{A_2 \cdot 1000}$$

1. Characteristic Fan Curve

This is the characteristic curve, which is determined on a test bed experimentally for every type of fan. This shows that the fan can in principle only operate on its characteristic curve, i.e. the operating point of a fan always lies on its characteristic curve.

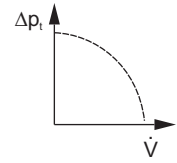

2. Characteristic Curve of the Plant

(Resistance Parabola)

Each plant has its own characteristic curve (resistance parabola), which by advance calculation can be determined more or less exact, so that the path of the characteristic curve can be drawn with sufficient accuracy.

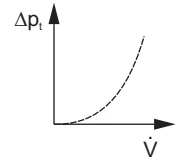

3. Coordination between Fan and Plant

The operating point of the fan always lies at the intersection of characteristic fan curve and characteristic plant curve (resistance parabola). From this results the actually moved volume flow, and the actual pressure difference to be overcome by the fan;

among others the characteristic fan curve V ($n = \text{const.}$) is given, also the characteristic plant curve 1, so that the operating point B_1 with \dot{V}_1 and p_{t1} results.

Figure a) shows the conditions for a centrifugal fan wheel with backward curved blading and figure b) the conditions for a centrifugal fan wheel with forward curved blading. If the volume flow is to be throttled by ΔV to \dot{V}_2 without reducing the fan Speed, it is generally customary to fit an additional resistance in form of a throttle valve, orifice or similar into the plant.

Figs. a) and b) show that a pressure loss of the size Δp_{st} must be fitted into the plant in order to reduce the volume flow to \dot{V}_2 . The resistance parabola 1 of the plant thus changes into 2 so that the operating point B_2 follows.

This shows that a fan with forward curved blading can be throttled more economically as one with backward curved blading.

A throttling of the fan speed is to prefer to any other method for sound reasons.

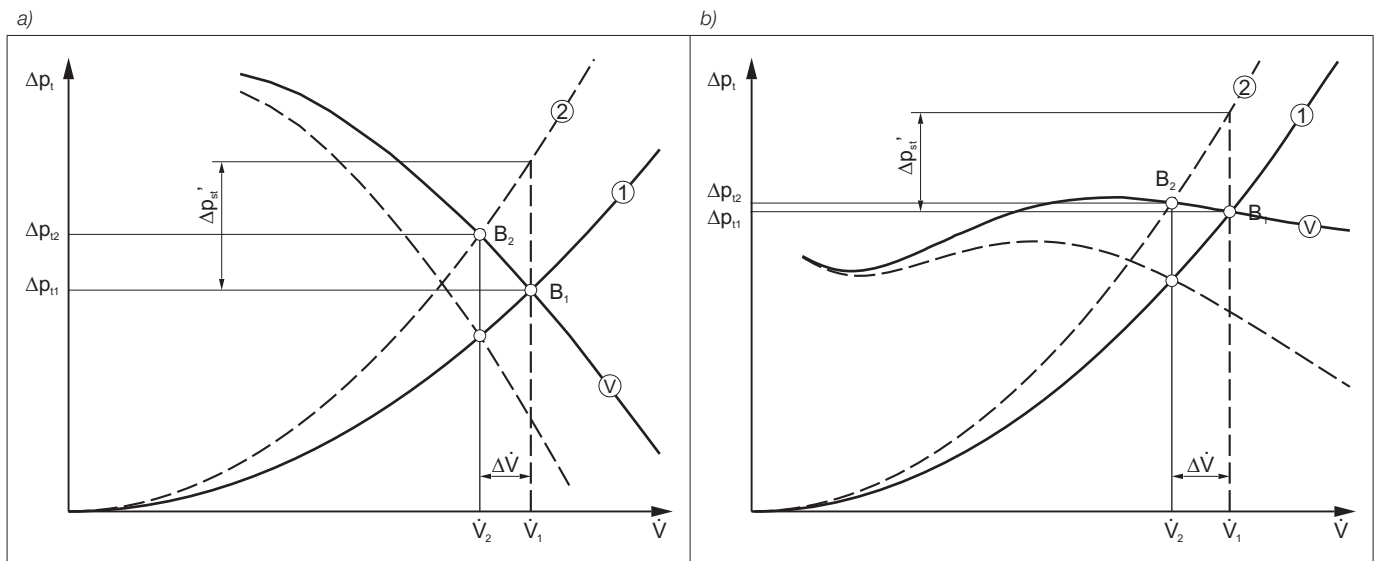

These fans are produced on modern machines and equipment. The rotors (impellers with shaft) are carefully balanced. Each fan is controlled and tested before it leaves the factory.

Before operating the fan, please check the following things

Check for transportation damages

Is the fan deformed? (Bulges, casing warped)

Does the impeller rotate without noise from the bearings, and without touching the inlet ring?

Check for foreign substances

Are there any foreign substances in the impeller or in the casing? If affirmative, it must be removed

Check for corrosion damages

The fans are supplied in very good galvanized finish. If stored for a longer period under humid and aggressive ambient conditions, zinc oxidizes. This has to be removed immediately (also inside the fan).

Assembly and mounting

The fan has to be mounted on the base or vibration dampers, with feet, square frame or base frame, in a way that it is not warped.

The shaft has to be horizontal.

Turn rotor (impeller with shaft) by hand. In case the impeller touches the inlet ring, loosen the inlet ring and refix it in a way that there is a uniform gap between inlet ring and impeller.

The fans are normally driven by a narrow belt drive. The instructions of the manufacturer of the belt drive have to be respected.

The bearings are temperature resistant from -30 degree C up to +85 degree C.

Depending on the location and way, how the fan is installed, different kinds of protection guards or devices could be necessary. DIN instructions or other instructions of local authorities or unions have to be respected.

The speed n_{max} indicated on the type plate may not be exceeded!

Operation

Switch on the fan for a short moment to check whether the direction of rotation is correct (See arrows at the fan casing).

If incorrect, change the direction of rotation by changing the wiring. (Respect the instructions of power supply companies).

Maintenance

The fans are maintenance free, only a control regarding contamination (fat, dust, etc.) has to be carried out.

The bearings are sealed for life with lithium base grease, suitable for approx. 20.000 operating hours. If the fan is operated more than 20.000 hours, or in case the bearings are damaged, they have to be exchanged (if bearings with rubber sealing, also this sealing has to be exchanged - a bearing chart is attached).

The bearings are equipped with a locking ring. To remove the bearing, this locking ring has to be loosened and the casing of the bearing has to be opened - then the bearing can be taken off from the cleaned and degreased shaft.

Important for a constantly good performance of the fan is a clean impeller.

Belt tension

Regular control of belt tension is very important. In any case, the belt tension has to be controlled after the first 100 operating hours, and then every 1000 operating hours or at least once a year. The belt tension is controlled by "pressing the belt with the fingers" (See drawing 1). A good tension is achieved by a total bending of approx. 2-3 cm. Used belts have to be replaced by belts of the same type. Control at the same time the fixation of the belt disc at the axis and the alignment of the belt. (See drawing 2)

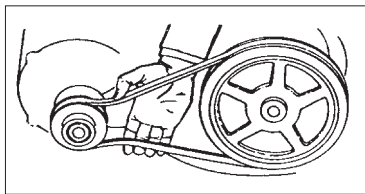

(Drawing 1) Belt tension bending of approx. 2-3 cm.

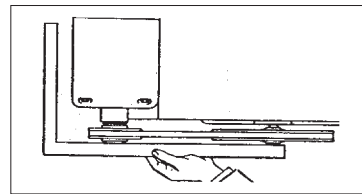

(Drawing 2) alignment of the belt disc.

Wolter Sales Network

Inland

Ing. Günther Rößler
D-07619 Schkölen
Tel. (+49) 03 66 94 / 22 359
Fax (+49) 03 66 94 / 22 357
guenther.roessler@wolterfans.de

Mattias Industrievertretungen
D-16259 Bad Freienwalde
Tel. (+49)03344/301994
Fax (+49)03344/301996
thomas.mattias@wolterfans.de

Industrieservice Drexler
D-49080 Osnabrück
Tel. (+49) 0 541 / 20 04 88 3
Fax (+49) 0 541 / 20 04 88 4
wolfgang.drexler@wolterfans.de

Burkhardt Projekt GmbH
D-67583 Guntersblum
Tel. (+49) 0 62 49 / 82 01
Fax (+49) 0 62 49 / 88 58
info@bp-wolter.de

Friedrich Glock
D-97980 Bad Mergentheim
Tel. (+49) 0 79 31 / 37 44
Fax (+49) 0 79 31 / 28 58
friedrich.glock@wolterfans.de

Europe

Danmark:

Aircon Teknik A/S
DK-8200 Aarhus N
Tel. +45 (0) 86 / 34 51 11
Fax +45 (0) 86 / 34 58 10
post@airconteknik.dk

The Netherlands:

AirFan B. V.
NL-7442 CX Nijverdal
Tel. (+31)054/8366366
Fax (+31)054/8365320
ventilatie@airfan.nl

Poland:

Wentoprodukt
44-100 Gliwice
Tel. (+48)32 33 13 424
Fax (+48)32 72 97 653 75
biuro@wentoprodukt.pl

Russia:

Daichi Co. Ltd
RU-123022 Moscow
Tel. +7 (0) 495 / 73 73 733
Fax +7 (0) 495 / 73 73 732
info@daichi.ru

Switzerland:

Anson AG Zürich
CH-8055 Zürich
Tel. (+41) 0 44 / 46 11 111
Fax (+41) 0 44 / 46 13 111
info@anson.ch

Ventra Technik AG
CH-8599 Salmsach
Tel. (+41) 0 71 / 46 11 447
Fax (+41) 0 71 / 46 11 448
ventra@bluewin.ch

Turkey:

Air Trade Centre Ltd Sti Türkiye,
TR-34418 Seyrantepe / Istanbul
Tel. (+90) 02 12 / 28 34 510
Fax (+90) 02 12 / 27 83 964
atc.turkey@airtradecentre.com

United Kingdom:

Wolter (UK) Ltd.
GB-Leicestershire LE65 1AL
Tel. (+44) 01530 / 412 473
info@wolteruk.com

Middle East and North Africa

Israel:

Pach Taas (Ashkelon) Ltd.
IL-78100 Ashkelon
Tel. (+972) 0 8 / 67 19 770
Fax (+972) 0 8 / 67 19 771
info@pachtaas.com

UAE, Qatar, Lebanon, Jordan,
Saudi Arabia:

Energy International Co.
UAE-Sharjah, P.O. Box 3562
Tel. (+971) 06 / 53 43 477
Fax (+971) 06 / 53 43 756
fsalibi@energysg.ae

Energy International Co.
P.O. Box 45217 Abu Dhabi, UAE
Tel. (+971) 2 67 11 10 8
Fax (+971) 2 67 69 669
amohsen@energyintl.ae

Energy International Co.(Dubai-Sharjah)
P.O. Box 3562 Sharjah, UAE
Tel. (+971) 65 34 34 77
Fax (+971) 65 34 37 56
fsalibi@energysg.ae

Energy International Corporation
Malaz Area, Siteen Highway Beside BANK
ALBILAD Riyadh, Saudi Arabia
Tel. (+966) 14 15 39 59
msheet@energyintl.com

Energy International Corporation
P.O. Box 37364 Doha, Qatar
Tel. (+974) 45 80 765
Fax (+974) 45 81 126
aassi@energyintl.com

Energy International
234 Balbesi Blg 2nd floor Al-Madinah,
Al Munawarah St Amman, Jordan
Tel. (+962) 65 67 19 15
Fax (+962) 65 67 19 16
eabuzahra@energyintl.com

Energy International & Engineering
Mar Roukoz Center-Block B - First Floor,
Hazmieh, Lebanon
Tel. (+961) 54 50 61 0
Fax (+961) 54 51 16 9
bsaab@energyintl.com

Asia

China Mainland:

Dongguan Wolter Chemco Ventilation Ltd.
Chemco Building, Miao Bian Wang Ind.
Shipai, Dongguan City, Guangdong
Tel. (+86) 0 769 / 8655 7298
Fax (+86) 0 769 / 8655 7278
info@wolterfans.com

Taizhou Wolter Ventilation Co. Ltd.
Hengjie, Luqiao District
Taizhou City, Zhejiang
Tel. (+86) 0 576 / 26 22 666 (26 52 888)
Fax (+86) 0 576 / 26 56 830

Hongkong:

Wolter Asia Ltd.
Hong Kong
Tel. (+852) 0 2456 0198
Fax (+852) 0 2456 0290
info@wolter.com.hk

India:

Wolter Ventilators India Pvt. Ltd.
867 D, Block-A, Sushant Lok, Phase-I,
Gurgaon - 122009 (Haryana)
Tel. +91 124 2577797, 4261001-3
sales@wolterindia.in

Indonesia:

PT Lung Makmur Abadi.
Kawasan Pergudangan Taman Tekno Blok
M/16, Serpong-Tangerang 15310
Tel. +62 (0) 21 / 7588 2609 ext 104
Fax +62 (0) 21 / 7588 2610
lma.wolter@gmail.com

Korea:

Kaceco-Wolter
14-1, Dang-dong, Gunpo-shi, Gyeonggi-do
Tel. +82 (0) 31 / 4773 104
Fax +82 (0) 31 / 4773 132
wolter@kaceco.com / info@kaceco.com

Malaysia:

Vibrantech (M) Sdn Bhd.
47200 Petaling Jaya Selangor, Malaysia
Tel. +603 (0) 7847 3500
Fax +603 (0) 7847 3380
sales@vibrantech-sb.com

Singapore:

Wolter Pte. Ltd.
SG-569738 Singapore
Tel. (+65) 0 63 / 52 95 48
Fax (+65) 0 63 / 52 95 47
info@wolterfans.com.sg

Sri Lanka:

Sirocco Air Technologies (Pvt) Ltd.
28/12, Gemunu Mawatha, Kotuwegoda,
Rajagiriya, Sri Lanka
Tel. +94 11 7 392 010
Fax +94 11 7 392 015
suren@sairt.com

Taiwan:

Waxlink International Co., Ltd.
8F-2 No.218 Roosevelt Rd., Sec.6
Taipei, Taiwan
Tel. (+886) 02 / 8932 1196
Fax (+886) 02 / 8932 1197
waxlink@mail.waxlinktw.com

Thailand:

Wolter Ventilation Co., Ltd.
Thamai Kratumban Samutsakorn 74110
Thailand
Tel. +66 (0) 3486 6555
Fax +66 (0) 3486 6599
natiphan@wolterfan.com

Australia

The Sydney Fan Company.
NSW 2147, Sydney, Australia
Tel. +61 (0) 2 / 9624 4000
Fax +61 (0) 2 / 9624 4100
sales@thesydneyfancompany.com

Wolter GmbH Maschinen-und Apparatebau KG

Am Wasen 11
D-76316 Malsch / Germany
Tel. +49 (0) 7204/9201-0
Fax +49 (0) 7204/9201-11
www.wolter.eu
info@wolter.eu





Reference: **M08.HRZ**, V2018/October, Printed in October, 2018