

Operating Instructions for

.....

Direct driven axial fans

AEQ / ADQ / AXV-PM / BXV-PM

AER / ADR

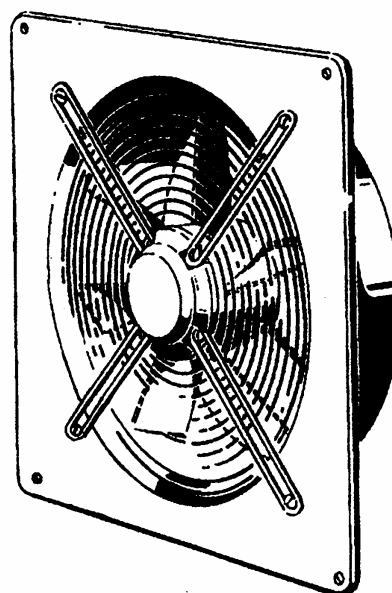
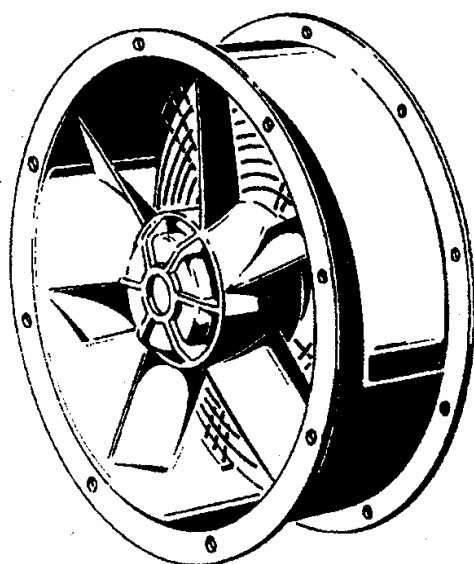

10 Contents

1	Contents	2
2	General safety notes	3
2.1	Safety warnings in this manual	3
2.2	Basic safety measures	3
3	Product description	4
3.1	Stipulated usage	4
3.2	Construction	4
3.3	Technical Data	4
4	Transportation and Storage	5
4.1	Transportation	5
4.2	Storage	5
4.3	Wight and dimensions	5
5	Installation	5
5.1	Mechanical installation	5
5.2	Electrical installation	6
5.3	Direction of rotation check	6
5.4	Wiring diagrams	7
6	Initial Start-up	7
6.1	Prepare fan for first operation:	7
6.2	Taking fan in operation:	8
7	Maintenance	8
7.1	Servicing and cleaning	8
7.2	Maintenance	9
7.3	Repair	9
7.3.1	Change of the motor impeller:	9
8	Service, Address of Manufacturer	9
9	EC Declaration of Conformity	10

11 General safety notes

This operation instruction contains important technical advice and information about safety. Therefore please pay attention to this operation instruction before unpacking, installation or any other work is undertaken on this fan!

11.1 Safety warnings in this manual

The following symbols are used in these operating instructions. These symbols are, above all, intended to draw the reader's attention to the text contained in the adjacent safety note.



Warning This symbol indicates that dangers exist which are hazardous to life and health.



Mortal danger Electrical hazard. Serious – and also fatal – injury can result if these notes are disregarded.



Mortal danger Danger from hanging loads! Do not work under floating load if it can be avoided.



Crush danger Attention, keep your hands from parts wearing this sign!





Note Indicates user tips and other useful advice.

11.2 Basic safety measures

Wolter fans are, at the moment of delivery, manufactured to the current level of technology.

Extensive material, function and quality checks assure them of a high level of usefulness and long service life! Nevertheless, these machines can be dangerous if they are improperly used by untrained personnel or are used in a non-stipulated manner.

- Read these operating instructions carefully before putting the fans into operation!
- If the fans are operated with an additional controller, please consider instruction of operation manual of controller.
- 
 - Only operate the fan in its enclosed state or with properly assembled protective anti-intrusion fittings, or with protective screens. (We can supply suitable, tested protective screens on request!)
 - The fan must only be used according to its design parameters, with regard to performance (→ data plate) and mediums passing through it!
- 
 - Assembly, electrical connection and maintenance may only be carried out by trained craftsmen!
 - Only operate the fan in the manner stipulated and within the specified output limits (see rating plate) and with approved conveyed media!
- The manual has to be placed near by the fan and must always be kept in readable status.
- No sign or warning placed onto the fans must be removed.
- Axial fans with square plate mounted arrangement; (series EQ / DQ) are supplied with inlet protection guards as standard on sizes up to 630 mm diameter. From size 710 mm upwards inlet guards are not fitted as a standard item. Guards can be supplied as an optional extra if required.
 - ☞ Great care should be taken at the installation stage to ensure that it is not possible to touch the impeller. If there is a possibility to do so, protection guards should be fitted relevant to the local health and safety requirements.
- Case mounted axial fans (Series ER / DR) are not fitted with protection guards as standard as they are usually positioned in a duct system which eliminates the possibility of touching the impeller. However, should this type of fan be installed in any system that leaves one or both faces of the fan exposed, then

suitable protection guards must be fitted in accordance with local health and safety requirements. These guards are available as an optional extra from our programme.

- ☞ When installing please check whether it is excluded to touch the impeller. If touching is possible a protection guard conforming to standards has to be mounted suitable and tested protection guards can be supplied as accessory.

12 Product description

Axial fans were especially developed for use in modern ventilation systems and air handling units. By using the external rotor motor there are significant technical advantages in operation over conventional axial fans. All radial fans are 0 to 100 % speed controllable and are statically and dynamically balanced as a composite unit in our factory.

12.1 Stipulated usage

Duct fans can be used for ventilation of:

- clean air
- air which has little dust and grease content
- slightly aggressive gases and fumes (please refer to our engineers)
- media up to a maximum air density of 1.3 kg/m³
- flow volumes at temperatures ranging from -30 °C to + 40 °C (out of these temperatures please see catalogue information)
- Mediums up to a max. humidity of 95% (avoid quick changes between dry and moistly air)



Do not use duct fans in explosive area

All other means of use of the fan would be meant to be a misuse.



- ☞ The fan must only be used with attached guards. However, should this type of fan be installed in any system that leaves one or both faces of the fan exposed, then suitable protection guards must be fitted in accordance with local health and safety requirements.
- ☞ To avoid damages of the fan, make sure that no parts can be sucked into the fans inlet.
- ☞ The fan must only be operated in the performance curve field right of the firing point, i.e.!

12.2 Construction

The axial fan consists of:

- (1) Steel fan housing
as a tube with ADR / AER
as a quadratic wall plate with ADQ / AEQ (without image)
- (2) motor impeller (radial impeller with integrated external rotor motor)
- (3) protection guard and motor support
- (4) external terminal box for electric installation with ADR / AER

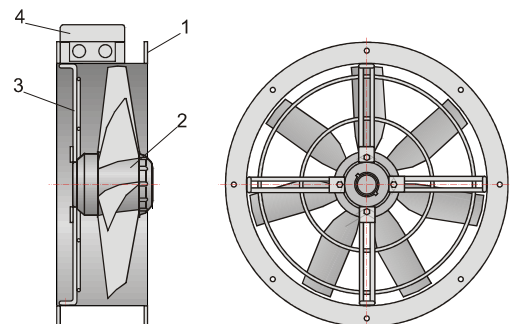

Direction of airflow is not reversible! It is shown by arrow stickers outside the housing.

12.3 Technical Data

For the actual technical data of the fan please refer to the data sheet.

13 Transportation and Storage

13.1 Transportation

Wolter fans are packed at the factory to suit the respectively agreed mode of transportation. Small parts are packed in cartooned transport package. Larger size will be send on reusable pallets.



- Use original packaging for transport
- Only use suitable means of transport, such as pallet trucks or fork-lift trucks.
- If the fan is to be transported by hand, ensure that supporting and carrying loads are kept within reasonable limits for the personnel involved (☞ weight as signed on the data plate).
- Use suitable assembling means as e.g. scaffolds conforming to specifications.
- Avoid a distortion of casing or blades or other damage.

The following special hazards must be taken into account when transporting the equipment:

- The transportation packaging does not prevent damage to the equipment through improper transportation. The fans must not be dropped or thrown.
- Sharp, protruding edges can lead to injury through cuts.



- Suspended loads can fall, which then constitutes a fatal hazard – stand well clear of suspended loads!
- Parts which have been stacked too high can collapse.
- A risk of fire exists due to the easily flammable nature of the packaging materials – do not use naked flames and do not smoke

13.2 Storage

- Store the fan in a dry, weather-protected location in its original packaging or protect it from the effects of dirt and the weather until final assembly.
- Cover open pallets with tarpaulin sheets and protect the fans from the effects of dirt and contaminants (e.g. swarf, stones, wire etc.)
- Avoid extremes of cold and heat. Storage temperatures between - 30 °C and + 40 °C.
- Avoid lengthy storage periods (a maximum of one year is recommended) and check that the motor bearing assembly is in good functional order prior to fitting.
- With storage times of more than 1 year please check the bearings on soft running before mounting (☞ turn by hand)

13.3 Wight and dimensions

For the actual technical data of the fan please refer to the data sheet.

14 Installation



Assembly, installation and electrical work is only to be carried out by trained and instructed craftsmen and in accordance with the respectively applicable regulations!



14.1 Mechanical installation

- Take care of direction of air flow shown by arrow stickers.
- Axial fans with square inlet cone plate (series EQ / DQ)
 - Installation only on a flat surface on the drilled holes in the inlet cone plates.

- ☞ Installation on an uneven surface may lead to deformation of the wall ring and may result in the impeller rubbing the fan casing.
- Axial fans with installation flange in either direction (series ER / DR)
 - These fans are preferred to be installed in duct systems.
 - ☞ Installation on an uneven surface may lead to deformation of the wall ring and may result in the impeller rubbing the fan casing.
- Any installation position is possible for all types and sizes.
- The hole for condensate in rotor resp. stator must be clear.
 - When mounting with vertical shaft the hole for drain of condensate on the bottom must be opened. The hole for drain of condensate on the top must be closed.
- Do not bend the fan.



Avoid sound bridges by use of isolation material (i.e. sponge rubber)

- Check impeller rotation by hand for soft running.



The duct system must not be supported by the fan casing!

14.2 Electrical installation

Electric wiring must be in accordance with technical connection regulations and local ordinances and national electric codes as per enclosed wiring diagram in the terminal box or on the casing.

- Check that supply is according to data on name plate
- Insert cable according to the instructions in the junction box and seal it (possibly „Water bag“).
- Connect thermal contacts for motor protection according to the instructions - otherwise the guarantee is invalid. Connect electric supply.



- ☞ Do not use metal compression-gland fittings with plastic terminal boxes.
- ☞ If the fan is operated with an additional controller, please consider instruction of operation manual of controller.



14.3 Direction of rotation check



The fans must only be used with attached and sealed tube. Otherwise there is danger of hazard from the rotating impeller. Parts could be sucked in by the air flow! One can reach the rotating impeller with his hand.

- Before checking direction of rotation:
 - Remove any foreign matter from the fan.
 - Rotate impeller by hand to check free running, prior to switching on power supply.
 - Install protection guards (☞ Accessories) or give no access to impeller.
- Check the direction of rotation against the direction arrow attached to the casing by quickly turning on and off the power supply.



Incorrect direction of rotation will overload the motor!
→ Thermal contact of motor activate

- ☞ With 3-phase-motor
to change direction of rotation transpose two of the phases!
- ☞ With 1-phase-motor
to change direction of rotation, transpose the position of leads Z1 (black) and Z2 (orange)
(→ change of current direction in secondary winding).

14.4 Wiring diagrams

Nr. E11

Single phase AC motor with capacitor and thermostat.
Thermostat led outside the motor and externally connected in series with the winding.

U1 = blue
U2 = black
Z = brown
PE = yellow-green

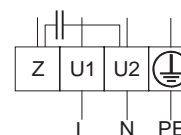

No. E13:

Single phase AC motor with capacitor and thermostat.
Thermostat led outside the motor and externally connected in series with the winding.

TK led outside for connection to the motor protection unit.

E13a

U1 = brown
U2 = blue
Z1 = black
Z2 = orange
TK = white
PE = yellow-green

E13b

U2 = black
U1/Z1 = blue
Z2 = brown
TK = grey
PE = yellow-green

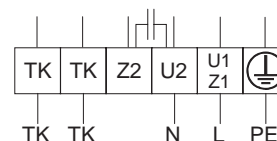

No. DD0:

3-Phase motor in Δ -connection with thermostat. Changing of rotation direction by interchanging 2 phases.

DD0a

U1/V1/W1 = brown
U2/V2/W2 = blue
TK = yellow
PE = yellow-green

DD0b

U1 = brown
V1 = blue
W1 = black
U2 = red
V2 = grey
W2 = orange
TK = white
PE = yellow-green

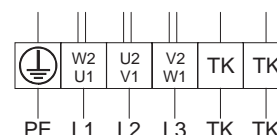

No. DD1:

3-Phase motor in Δ -connection with thermistor. Changing of rotation direction by interchanging 2 phases.

U1 = brown
V1 = blue
W1 = black
K = white
U2 = red
V2 = grey
W2 = orange
PE = yellow-green

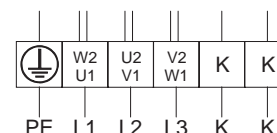

15 Initial Start-up

15.1 Prepare fan for first operation:

- correct mechanical installation

- electrical installation in accordance with regulations
- remove foreign matter from inlet and outlet area and from inside of fan
- Protection guard (☞ accessories) installed, no entry to fan or fan being installed out of arm sweep.

15.2 Taking fan in operation:



Only put the fan into operation after it has been assembled in accordance with the regulations!

- If the fan is started under free blow conditions, i.e. prior to connecting to ducting system, the current consumption may exceed the normal maximum (forbidden area of performance curve)!
→ The terminal protection of the motor may activate!

- Put the fan into operation.
- Observe and check for the following - smooth vibration free running, uniform power consumption, a good controllability.



By regular inspection of the fan inlet make sure debris has not collected on the guard and clean if necessary!

16 Maintenance



Our fans are maintenance free with normal operation! When using them in the fringe range simple maintenance work may be required!



In case servicing has to be done anyway:

- Bring the fan to a halt in the prescribed manner and completely isolate the fan from the mains supply!
- **Wait until the rotor has come to a halt!**
- **Ensure that the machine cannot be switched on again**

The following safety notes must be observed when maintaining the machine.



- Unexpected reconnection to power supply could lead to serious harm. The fan has to be assured against accidental switch-on
- Risk of injury at sharp-edged parts of fan housing.
- Insecure manual operation leads to a high risk of injury by shearing at the fan impeller. Never reach into the moving fan! Wear formfitting cloth – prevents catching cloth by airflow and winding up at the impeller.

16.1 Servicing and cleaning

- Dismount motor impeller (→„Repair“)

Clean fan:

- clean inlet cones
- clean impeller (if necessary dismount protection guards)

	Normally the impeller should not show any sign of debris to ensure proper work of fan. If there is debris anyway, please check your air filter.
	<p>Periodical cleaning prevents to rotor to become out-of-balance.</p> <ul style="list-style-type: none"> ☞ Vacuum-clean would be best. ☞ Compressed-air must not be used! Dirt could be pressed into the bearings and causes consequential damage. ☞ High-pressure cleaner must not be used! ☞ Do not damage the impeller!

	<ul style="list-style-type: none"> ☞ Do not flood motor! ☞ Do not bend impeller, blades!
--	--

- Install protection guard

16.2 Maintenance

General controls:

- Bearing play too large?
- Grease leaking on bearings?
- Surface protection affected (☞ medium to be ventilated too aggressive!)?
- Unusual operation noise?
- Fan capacity for possibly exceeded duct system still sufficient? (☞ forbidden area of performance curve!)?

16.3 Repair

	<p>Before any repairs are undertaken please:</p> <ul style="list-style-type: none"> – Stop fan in accordance to regulations and disconnect all poles from mains supply. – Wait until impeller is stationary! – Make sure that a restart is not possible!
---	--

	<p>Only use original spare parts manufactured and supplied by Wolter!</p>
--	--

16.3.1 Change of the motor impeller:

- Disconnect electric supply.
- Dismount protection guard.
- Unscrew motor suspension (protection guard) and pull out of casing or wall plate complete with motor impeller.
- Dismount motor suspension (protection guard) from motor impeller.
- Mount new motor impeller on protection guard, insert in wall plate (casing) and secure with screws.
- Connect electric supply of motor (→ “installation”).
- Control whether installation is correct
 - ☞ motor impeller must rotate free
 - ☞ Annular gap between impeller and wall plate / casing must be regular.
 - ☞ control whether direction of rotation is correct (→ “Installation“)

17 Service, Address of Manufacturer

Wolter-products are subject to steady quality controls and are in accordance with valid regulations.

In case you have any questions with regard to our products please contact either your constructor or directly to one of our distributors:

Wolter GmbH Maschinen- und Apparatebau KG
Am Wasen 11
D-76313 Malsch-Völkersbach

Tel.: 07204/9201-0
Telefax: 07204/9201-11
Internet: www.wolterfans.de
email: info@wolterfans.de

18 EC Declaration of Conformity

The manufacturer: **Wolter GmbH
Maschinen- und Apparatebau KG
Am Wasen 11
D-76316 Malsch**

hereby declares that the machine described in the following: **Direct driven axial duct fans of versions ADR, AER, ADQ, AEQ**

meets the health and safety requirements of the following EC Directives: **In accordance with Machinery Directive (98/37/EG), Appendix II A
in accordance with the Low Voltage Directive (73/23/EWG)
in accordance with the EMC Directive 89/336/EWG**

Harmonised standards applied:

DIN EN 292-1	Machine safety; Basic terms, general guiding principles of lay-out; Part 1: Basic terminology, methodology
DIN EN 292-2	Machine safety; Basic terms, general guiding principles of lay-out; Part 2: Technical guidelines and specifications
DIN EN 294	Machine safety; Safety distances for the prevention of upper limbs coming into the vicinity of danger areas
DIN EN 50081 part 1 a. 2	Subject basic standard; Emitted interference
DIN EN 50082 part 1 a. 2	Subject basic standard; Interference resistance
DIN EN 60335-1	Safety of electrical equipment for household use and similar purposes; Part 1: Basic requirements

National standards and technical specifications applied:

--	--

Any changes in construction which have an effect on the technical data specified in the operating instructions and on the fan's stipulated usage, i.e. those changes which essentially change the fan, shall invalidate this declaration of conformity!

Malsch, 14.04.2005



Hans Rudolf Kresse, Geschäftsführer