



## Radialventilatoren

- aus chemisch widerstandsfähigem Kunststoff

High Pressure Chemical Resistant Centrifugal Fans

# R06.1

**wolter** 

Inhaltsverzeichnis	Contents	1
Technische Informationen	Technical information	2-5
Ventilatorcurven	Fan curves	6-20
Abmessungen	Dimensions	21-25
Ausschreibungstexte	Specification	26-31

WOLTER CHEMCO chemisch widerstandsfähige Kunststoff-Lüfter  
CHEMCO = chemical resistant plastic fan

### Rolle

Wolter Chemco spielte eine führende Rolle bei der Herstellung von Gegenständen aus nicht rostenden und chemisch widerstandsfähigen Kunststoffen. Diese Geräte sind bestens geeignet für Belüftungs- & Lärmbekämpfungssysteme, Reinraumtechnik, Galvanisier-Anlagen, Laboratoriums-Abflüsse & Behälter, Bürsten, Wasserspeicher und kundenspezifische Systeme.

### Erfahrung

Aufgrund der langjährigen Erfahrung und Know-How im Kunststoffbereich, war es Chemco möglich eine komplette Baureihe von nicht rostenden Ventilatoren zu entwickeln. Die Ventilatoren zeichnen sich durch einen hohen Wirkungsgrad, zuverlässiges Betriebsverhalten und hervorragende Korrosionsfestigkeit aus. Grundmerkmale sind ebenso die einfache Wartung und die Wirtschaftlichkeit.

### Anwendung

Chemco korrosionsbeständige Kunststoff-Ventilatoren sind speziell entwickelt um schwerkorrosive Rauchgase, Dämpfe, verseuchte Luft und aggressive Gase zu handhaben. Solche Ventilatoren eignen sich zum Gebrauch im Prüflabor, Krankenhaus, Nahrungsmittelindustrie, Elektronikindustrie, chemisch und galvanische Metallbeschichtungs-Gewerbe, Reinraumtechnik usw. oder auch für die Luftaufbereitung in der Bauindustrie.

### Gütegrad

Chemco bietet eine komplette Baureihe wirkungsvoller rückwärtsgekrümmter Radialventilatoren hoher Qualität mit sehr guter Leistung und niedrigem Geräuschpegel. Alle Ventilator-Antriebe und Zubehör werden nach genauen Qualitätsstufen hergestellt. Es kommen nur Qualitäts-Werkstoffe zum Einsatz und alle Ventilatoren sind erprobt und geprüft nach DIN 24163, ISO 5801 und AMCA 210.

### Erzeugnisse und Leistung

Chemco Radial-Ventilatoren und Dachventilatoren mit horizontalem oder senkrechtem Ausblas bieten Leistungen von bis zu 180.000 m<sup>3</sup>/h und statischem Druck von bis zu 7500 Pa.

Thermoplastische Kunststoffe wie PP, PE, PVC, PVDF oder GFK die Widerstandsfähigkeit gegen die meisten Chemikalien bieten sind verfügbar.

### Schallpegel

Um eine Bewertung entsprechend dem menschlichen Gehör zu ermöglichen wurde die A-bewertete Beschreibung des Schallpegels gemäß DIN 45635 gewählt.

Die Schallmessung erfolgt mit dem Hüllflächenverfahren gemäß DIN 45635 Teil 38 oder dem Kanalverfahren DIN 45635 Teil 9 oder AMCA 300 45635.

WOLTER CHEMCO CHEMICAL RESISTANT PLASTIC FAN  
CHEMCO = chemical resistant plastic fan

### Role

Wolter Chemco has played a leading role in the manufacturing of equipment made from anti-corrosive and chemical resistant plastics. These equipment are most suitable for use in the ventilation & noise control systems, clean rooms engineering, plating equipment, laboratory sinks & containers, scrubbers, tank constructions as well as custom design systems.

### Experience

The years of experience and know-how in the areas of plastics, its designing capability enables Chemco to develop a complete range of anticorrosive fans. The fans are specially designed for high efficiency, reliability, with superior corrosion resistance quality. They are also developed to give trouble-free service, and are economical in use.

### Application

Chemco corrosive resistant plastic fans are specially developed to handle heavy corrosive fumes, vapours, contaminated air and aggressive gases. Such fans are suitable for use in the test laboratory, hospital, food industry, electronic industry, chemical and electroplating industry, clean rooms engineering etc. They are also suitable for air conditioning application in the building industry.

### Quality

Chemco supply a complete range of highly quality and efficient radial tip backward curve fans, which offer an excellent performance with a low noise level. All fans drive and accessories are produced to strict quality standards. Only the best quality materials are used and all fans are tested and rated in accordance with DIN 24163, ISO 5801 and AMCA 210.

### Products and Performance

Chemco centrifugal fans and roof fans with horizontal or vertical outlet have performance capacity of up to 180,000 cmh and operating at a static pressure of up to 7500 Pa.

Thermoplastic materials such as PP, PE, PVC, PVDF or GRP that offer the best guarantee to resist most chemicals are available.

### Sound Level

In order to make possible an assessment of sound projection adequate to human ear the A-assessed description of sound level according to DIN 45635 has been chosen.

The ascertaining of the sound power level follows the enveloping surfaces method according to DIN 45635 section 38, section 9 or AMCA 300 45635.

## Standardbaureihen und Ausführungen Standard Models and Designs

### Typ CHEM LS 125-160 DD

- mit Direktantrieb
- Kunststoff Spritzgussgehäuse standardmäßig aus PP
- Gehäuse passend für beide Drehrichtungen, montiert auf verzinktem Stahl-Bock, mit angeflanschem Normmotor
- Laufrad fliegend auf Motorwelle montiert
- Ventilator-Bock mit Stützwinkeln

### Typ CHEM LS 125-160 BD

- mit Riemenantrieb
- Kunststoff Spritzgussgehäuse standardmäßig aus PP
- Gehäuse passend für beide Drehrichtungen, montiert auf verzinktem Stahl-Bock, Doppel-Flanschlager aus Gußaluminium
- Laufrad fliegend auf Welle montiert
- Ventilator-Bock mit Kanal-Lagerung und Motormontageplatte.

### Model CHEM LS 125DD to 160DD

- With direct drive
- Plastic injection moulded casing with PP as standard.
- Casing suitable for dual rotations mounted on the galvanised steel support comes with flanged standard motor
- Impeller mounted overhung on the motor shaft.
- Fan base with angle support

### Model CHEM LS 125BD to 160BD

- With belt drive.
- Plastic injection moulded casing with PP as standard.
- Casing are mounted on the galvanised steel support come with aluminium cast flanged-on twin bearing housing.
- Impeller fixed overhung on the shaft.
- Fan base with channel support include motor mounting plate.

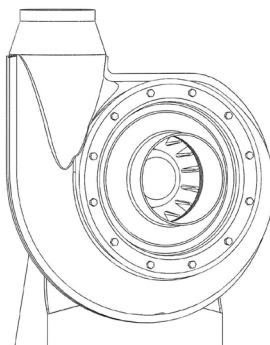

CHEM LS 125 - 160

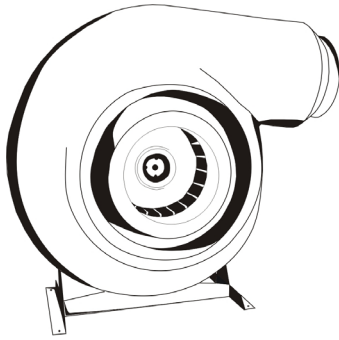

CHEM LS 200 - 315

### Typ CHEM LS 200-315 DD

- mit Direktantrieb
- Glasfaserverstärkt (GFK/FFK)
- Gehäuse mit angeflanschem Normmotor, montiert auf verzinktem Stahl-Bock
- Laufrad fliegend auf Motorwelle montiert
- Ventilator-Bock mit Stützwinkeln

### Model CHEM LS 200DD to 315DD

- With direct drive
- Glass-Reinforced Plastic (GRP/FRP) casing
- Casing mounted on the galvanised steel support comes with flanged standard motor.
- Impeller mounted overhung on the motor shaft.
- Fan base with angle support

### Typ CHEM LS 200-315 BD

- mit Riemenantrieb.
- Glasfaserverstärkt (GFK/FFK)
- Gehäuse montiert auf verzinktem Stahl-Bock, Doppel-Flanschlag aus Gußaluminium
- Laufrad fliegend auf Welle montiert
- Ventilator-Bock mit Kanal-Lagerung und Motor-montageplatte

### Model CHEM LS 200BD to 315BD

- With belt drive.
- Glass-Reinforced Plastic (GRP/FRP) casing
- Casing mounted on galvanised steel support comes with aluminium cast flanged-on twin bearing housing.
- Impeller fixed overhung on the shaft.
- Fan base with channel support include motor mounting plate

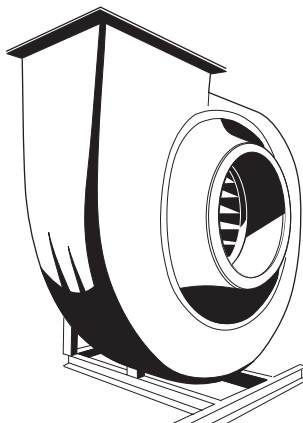

CHEM LS 355 - 630

### Typ CHEM LS 355-630 DD

- mit Direktantrieb.
- Gehäuse als maschinell geschweißte Kunststoff-Konstruktion oder aus glasfaserverstärktem Kunststoff (GFK/FFK)
- Gehäuse an verzinktem Lagerbock montiert, mit Norm-Fußmotor
- Laufrad fliegend auf Motorwelle montiert
- Ventilator-Bock mit Kanal-Lagerung

### Model CHEM LS 355DD to 630DD

- With direct drive.
- Casing in plastic mechanically welded construction or Glass-Reinforced Plastic (GRP/FRP)
- Casing mounted on galvanised steel support come with foot mounted standard motor.
- Impeller mounted overhung on the motor shaft.
- Fan base with channel support

### Typ CHEM LS 355-1000 BD

- mit Riemenantrieb.
- Gehäuse als maschinell geschweißte Kunststoff-Konstruktion oder aus glasfaserverstärktem Kunststoff (GFK/FFK)
- Gehäuse an verzinktem Lagerbock montiert, Welle mit Pendelkugel-Stehlager
- Laufrad fliegend auf Welle montiert
- Ventilator-Bock mit Kanal-Lagerung und Motor-montageplatte

### Model CHEM LS 355BD to 1000BD

- With belt drive.
- Casing in plastic mechanically welded construction or Glass-Reinforced Plastic (GRP/FRP)
- Casing mounted on galvanised steel support frame come with "pedestal" mounted self-aligning ball bearing units.
- Impeller fixed overhung on shaft.
- Fan base with channel support include motor mounting plate

Bei allen CHEM LS 200 bis CHEM LS 1000 ist das Laufrad standardmäßig aus PP oder GFK G1 und G3. Das Ventilatorgehäuse gewöhnlich aus GFK/FFK, bietet gute Säure- und Laugenfestigkeit. Es kann ebenso mit Einlagen vermischt werden um Anforderungen an Hochtemperatur-, UV-Beständigkeit oder Schutz vor elektrostatischer Entladung zu genügen. Je nach Kundenwunsch.

All CHEM LS 200 to CHEM LS 1000 impeller come with PP as standard, GRP G1 and G3 as optional. The fan casing usually of GRP/FRP material, good for chemical resistance, can also be blended with composites to overcoming high temperature, flame retardant, UV or Electrostatic Discharge protection to suit customer's requirements.

### Standard Farben

sämtliche PP - entsprechend PANTONE warm grau 1C,  
sämtliche GFK - entsprechend PANTONE 430  
Andere Farben wenn erforderliche.

### Standard Colour

All PP - Equivalent to PANTONE Warm Grey 1C,  
All GRP - Equivalent to PANTONE 430  
Other colour as optional required.

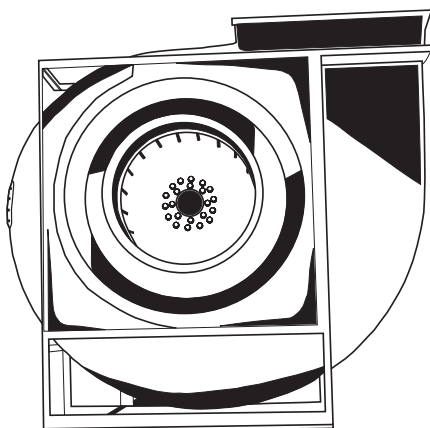

CHEM LS 710 -1000

### Sicherheitstechnische Besonderheiten

Sämtliche Riementriebe, Scheiben, vorstehend Stellschrauben, Keile und andere rotierende Teile haben Verkleidungen aus strapazierfähigem perforiertem Blech, um sicherheitstechnische Forderungen zu erfüllen. Jeder Ventilator hat ein festmontiertes Typenschild mit Seriennummer und Modellbezeichnung, Lüfter + Antriebsdaten, Luftmenge und Fabrikationsdatum.

### Safety Features

All drive-belts, pulleys, projecting set screws, keys and other rotating parts have heavy-duty perforated sheet as protective guards to meet safety requirement. All fans are labelled with nameplate securely attached on each fan showing the serial and model number, fan & drive duties, rotation of flow and date of manufacture.

### Konstruktion der chemisch beständigen Radiallüfter

#### Gehäuse

Das Ventilatorgehäuse ist entweder aus thermoplastischen Kunststoffen wie PP, PVC, PE, PVDF oder Glasfaserverstärkten Kunststoffen - Vinyl Ester Klasse (GFK oder FFK). Das Ventilatorgehäuse hat die Form einer echten Spirale und hat eine Hochleistungsansaugdüse um eine gleichmäßige Luftverteilung über die volle Laufradbreite zu erreichen.

Die kleineren Gehäuse, Typ **CHEM LS 125 - 160** sind vollständig aus Spritz-Kunststoff und passen sowohl für rechte als auch für linke Drehrichtung. Die Rückscheibe und Ansaugdüse, beide aus Spritzkunststoff, können leicht entfernt und getauscht werden um die Drehrichtung anzupassen oder bei Wartungsarbeiten. Ventilatorgehäuse mit Ausblasflansch werden mit chemisch beständiger Dichtung zur Vermeidung von Luftleckage geliefert. Standardmaterial des Gehäuses ist PP.

Die **CHEM LS 200 - 315** Gehäuse sind gewöhnlich aus GFK oder vacuumgeformt und maschinell geschweißt. Die Rückscheibe und Ansaugdüse, beide aus Spritzkunststoff, können für Wartungsarbeiten leicht entfernt werden. Thermoplastische Kunststoff-Ventilatorgehäuse mit Ausblasflansch werden mit chemisch beständiger Dichtung zur Vermeidung von Luftleckage geliefert. Die GFK Ventilatorgehäuse haben einen runden geraden Ausblas passend zur direkten Montage eines elastischen Verbinders.

Die Gehäuse der größeren Ventilator-Baureihen (Typen **CHEM LS 355 - 1000**) sind standardmäßig aus GFK oder, wenn erforderlich, maschinell geschweißte.

Das Chemco Ventilatorgehäuse ist äußerst starr, mit angemessener Dicke, speziell versteift, um Schwingungen oder Poltern während des Betriebes auszuschließen. Um das Risiko der Korrosion zu verringern ist das Gehäuse so gebaut, dass sich keine Metallteile im Luftstrom befinden. Die Gehäuse können aus GFK oder einem thermoplastischen Material vermengt mit Füllstoffen sein um Anforderungen an Hochtemperatur-, UV-Beständigkeit oder Schutz vor elektrostatischer Entladung zu genügen. Je nach Kundenwunsch.

Der Ansaug und Ausblas haben Standard-Durchmesser, welche während der Montage leicht mit passenden elastischen Verbindern angeschlossen werden können.

Alle Gehäuse können am tiefsten Punkt der Spirale mit einem Kondensatablaufstutzen versehen werden. Dies erleichtert die Entwässerung von Kondensat bei Aufstellung im Freien.

#### Rückwärtsgekrümmte Radiallaufräder

Chemco Lüfterlaufräder sind einflutrig mit konstanter Breite (SISW). Die Herstellung erfolgt durch Präzisions-spritzguß mit eingegossener Metallnabe (Typen **CHEM LS 125 - 315**) oder maschinell geschweißte (Typen **CHEM LS 355 - 1000**). Sie entsprechen höchsten Qualitätsstufen und haben ausgezeichnete aerodynamische Eigenschaften.

Als Standard wird PP für das Laufrad verwendet, je nach Einsatzfall können auch Pa, PC, PVC oder PVDF Verwendung finden. Entsprechend den Anforderungen des Kunden an Hochtemperatur-, UV-Beständigkeit oder Schutz vor elektrostatischer Entladung können die Laufräder auch aus einem thermoplastischen Material vermengt mit Füllstoffen sein. Jedes Laufrad ist, nach Q2,5 (VDI 2060) oder Gütegrad G2,5 (BS 5625 Teil 1 (1979)), statisch und dynamisch in zwei Ebenen gewuchtet. Die Radnaben sind für die Verwendung von Taper-lock-Naben vorgesehen und sind aus hochwertigen Gußplatten. Dies gewährleistet einen zuverlässigen Lauf auch bei hoher Umfangsgeschwindigkeit.

#### Ventilatorbock und Lager

Die Ventilatorenböcke und Grundrahmen sind aus schweren Walzstahlprofilen hergestellt und feuerverzinkt. Dies bietet besten Schutz bei widrigsten Bedingungen. Spezielle Oberflächenbehandlungen sind auf Wunsch möglich. Der Ventilator kann in verschiedene Ausblasrichtungen gedreht werden.

#### Achsenwelle und Lager

Abgedrehte Präzisionswellen nach DIN 17210 - C45 mit einem glatten Anstrich. Beide Wellenenden haben Norm-Durchmesser nach DIN 748, Blatt 1 und Nuten nach DIN 6885, Blatt 1. Die Wellen sind zur Vermeidung von Korrosion chemisch widerstandsfähig beschichtet. Auf Anfrage können auch Wellen aus rostfreiem Stahl geliefert werden.

Die riemengetriebenen Ventilatoren der Typen **CHEM LS 125 - 200** besitzen Flanschlager aus Gußaluminium. Die Antriebswelle hat zwei spielfreie Standard-Rillenkugellager mit säurebeständiger Dichtung. Diese Konstruktion sichert störungsfreien Betrieb, ruhigen Lauf und minimale Schwingungen.

Für **CHEM LS 250** und größer werden die Antriebswellen mit Bocklager aus Gußeisen auf dem Ventilatorbock montiert. Es werden entweder Pendelrollen- oder Pendelkugellager verwendet.

#### Antriebe

Genau gewuchtete Standard-Keilriemen-Scheiben mit Spannhülse, nach ISO 4183-1980. Alle Keilriemen entsprechend ISO 4148. Die Riementriebe werden entsprechend der benötigten Leistungen ausgewählt und korrekt verspannt was lange Standzeiten sicherstellt.

### Chemical Resistant Centrifugal Plastic Fan Design

#### Casing

The fan casing is constructed from thermoplastic such as PP, PVC, PE, PVDF or Glass reinforced plastic -Vinyl ester grade (GRP or FRP). The fan casing is built to a true volute form and has high efficiency inlet cone to give an even distribution of air over the full width of the runner.

The smaller range of casing, model **CHEM LS 125 - 160** are completely plastic injection moulded suitable for dual rotation at any position. The plastic injection moulded backplate or inlet cover can be easily removed for changing of rotation, maintenance and services. Fans casing with outlet flange come with chemical resistant seal to prevent air leakage. Casing usually with PP as standard.

The **CHEM LS 200 to 315** casing usually of GRP construction or vacuum-formed and automatic machine welded. The plastic injection moulded backplate can be easily removed for maintenance and services. Thermoplastic fans casing with outlet flange come with chemical resistant seal to prevent air leakage. The GRP fans casing come with round straight outlet suitable for direct connection to flexible connector.

For larger range of fans (Models **CHEM LS 355 - 1000**), the casing is usually of GRP construction as standard or by mechanically machine welded as when required.

Chemco fan casing is extremely rigid with adequate thickness, properly stiffened to ensure it is free of vibration or drumming during operation. The casing is also constructed in a way that no metal parts are situated in the airflow to eliminate the risk of corrosion. Casing can be of GRP or any thermoplastic material blended with composites to overcome high temperature, flame retardant resistant, ultraviolet or Electrostatic Discharge protection to suit customer's requirements.

The inlet and outlet are of standard diameter sizes, which can be easily connected together with flexible connector during installation.

All casings can be fitted with drain outlets at the lowest point of the scrolls. This is to facilitate the drainage of condensation build-up or rainwater when installed in the open.

#### Radial Tip Backward Curve Impellers

Chemco fan impellers are of single inlet Single width (SISW) type. Impellers are of precision plastic injection moulded design with cast-in metal hub (Models **CHEM LS 125 - 315**) or mechanically welded construction (Models **CHEM LS 355 - 1000**) to highest quality standard with excellent aerodynamic properties.

Impeller is usually of PP however, depending on the type of applications; impeller can be made of PA, PC, PVC or PVDF. Impeller can be thermoplastic material blended with composites to overcome high temperature, flame retardant resistant, ultraviolet or Electrostatic Discharge protection to suit customer's requirements. Each impeller is statically and dynamically balanced in two planes in accordance with Q2.5 of VDI 2060 or Grade G2.5 of BS 5625 Part 1 (1979). The hubs are designed for use with taper-bushes and are made of high-grade cast plates to guarantee high reliability at the high peripheral speeds.

#### Fan Base and Support

The fan supporting steel stands and fan bases are manufactured from heavy gauge mild steel and are hot dipped galvanised to provide maximum protection in the most adverse condition. Special surface treatment can be done on request. Fans can be rotated to suit different discharge directions.

#### Drive shaft and bearing

All precision solid shafts complying to DIN 17210 - C45 are trued and have a smooth finish. Both shaft ends have as standard feature diameters complying with DIN 748, Sheet 1 and grooved to DIN 6885, Sheet 1. The shafts are chemical resistant coated with protective cover to prevent corrosion. Upon requested, stainless steel shaft can also be provided.

**CHEM LS 125 - 200** belt driven fans come with flange mounted aluminium cast bearing housings type. The drive shaft is fitted with two standards anti-friction grooved balls bearing unit with acid proof seal. This design ensures trouble-free service, silent operation and minimum vibration.

For **CHEM LS 250** and above, the drive shafts are mounted on fan pedestal with cast iron housing of plummer block units. These bearings are of self-aligning heavy-duty ball or spherical roller type.

#### Drives

Standard pulley drive with taper bush type, accurately balanced and conform to ISO 4183-1980 standards. All Vee belts are conform to ISO 4148. Belt section is selected with correct ratings and tensioning to ensure prolonged usage.

### Motor

Je nach Anwendung sind Norm-Motoren von IP44, IP45, IP54 oder IP55 auf Anfrage lieferbar.

Bei direktgetriebene Ventilatoren werden B5 Flansch-Motore eingebaut, für riemengetriebene Ventilatoren, B3 Fuß-Motore. Alle Motoren sind vollständig geschlossen und luftgekühlt und erfüllen BS 2613. Die Standard-Motoren sind einphasig/dreiphasig, 50/60 Hertz passend für 240/415 oder 220/380 Volt. Andere Spannungen sind auf Anfrage lieferbar.

### Tropenfestigkeit

Die Motor-Wicklungen sind mit Harz-Lacken ummantelt, welche den Motor passend für tropische Atmosphären machen. Zusätzlich Behandlungen können durchgeführt werden, wenn Motoren in extreme-tropischer Umgebung arbeiten sollen.

### Explosionsschutz

Alle Ventilatoren mit Ex-Motoren sind für die folgenden Bereiche zugelassen:

- 1) BS 4683 Part II zertifiziert für die Gruppen IIa und IIb
- 2) BS 4683 Part IV, mit EXE bezeichnet und passed zum Gebrauch in Bereichen der Zone 1 für die Gruppen IIa und IIb.
- 3) BS 5000 Part 16 und BS 4683 Part III, mit EXN bezeichnete Typen, passend zum Gebrauchen in Bereichen der Zone 2.

EX-Schutz-Bereiche Zone 1 und 2, wenn innerhalb nicht explosionsgefährdeter Bereiche der Temperaturklassen T1-T3 installiert, aber nur unter den folgenden Bedingungen:

- a) Reduzierung der maximal erlaubten Drehzahl um 20%
- b) Reduzierung der erlaubt Antriebsleistung  $P_w$  um 30%
- c) nur Ventilatoren mit horizontalem Kanal verwenden
- d) der Ventilator muß mit Schutzgittern ausgestattet sein, die das Hineinfallen oder Angesaugtwerden von Fremdkörpern in den Ventilator wirkungsvoll verhindern.

### Inspektionsöffnung/klappe

für Instandhaltung und Wartung. An den Typen CHEM LS 450 und größer kann auf Anfrage eine Inspektionsklappe angebracht werden. Diese Klappe erfüllt die allgemeinen Sicherheits- und Unfallverhütungsvorschriften, da sie nur unter der Verwendung von Werkzeuge geöffnet werden kann.

### Zubehör

- Anbau von Feder-Schwingungsdämpfer
- Kondensatablaufstutzen mit Verschluss
- Motor, Motorschutz, Spannschlitten -Schienen, Riemenschutz, Riemenantrieb
- Lager, Abdeckung für Lager und Welle
- Ventilatorgrundrahmen
- Ansaugflansch, Ansaugmanschette mit Klemmband
- Splitter Schutzhaube.

### wahlweise

- andere Farbe aus der gesamten Farbpalette
- flammhemmend
- Hochtemperatur
- elektrostatische Entladung – Anti-statisch, statisch verlustbehaftet oder leitend
- UV-beständig

### Thermische und chemische Beständigkeit

Die Temperatur der Luft oder der Gase dürfen den für den Werkstoff angegebenen Wert nicht überschreiten:

Werkstoff	max. Temp. [°C]
PVC	60
PP	80
GFK	100
PVDF	120

Für eine ausführliche Liste der chemischen Anwendung wenden Sie sich bitte an unsere örtliche Vertretungen.

### Motor

Depending on the application, standard electric driven motor of IP44, IP45, IP54 or IP55 can be supplied upon request.

For direct driven fans, motor are usually of B5 flange mounting and for belt driven fans, motor are of B3 foot mounting. All motors are totally enclosed and fan cooled complying with BS 2613. The motors are single/three phase, 50/60 Hz suitable for 240/415 or 220/380 volts standards. All other voltage can be supplied upon request.

### Tropicalisation

Motor windings are coated with resin varnishes, which make the motor suitable for tropical atmospheres. Additional treatment can be carried out where motors are required to operate in severe tropical environments.

### Flameproof

All fans mounted with flameproof motors are suitable in the following areas:

- 1) BS 4683 Part II certified for Groups IIa and IIb
- 2) BS 4683 Part IV designated EXE and are suitable for use in Zone 1 areas for group IIa and IIb.
- 3) BS 5000 Part 16 and BS 4683 Part III designated type EXN and suitable for use in Zone 2 areas.

Flameproof areas zone 1 and 2, when installed in non-explosion hazardous area for temperature categories T1-T3, but only under the follow conditions:

- a) the maximum allowed revolutions must be reduced by 20%
- b) the allowed drive power  $P_w$  should be reduced by 30%
- c) only fans with horizontal shafts are to be used
- d) fans must be equipped with guards to prevent foreign particulars falling in or being sucked in.

### Inspection Door/Cover

For servicing and inspection purposes. For model CHEM LS 400 and above, an inspection cover can be included upon request. This cover is complies in general with safety and accident prevention regulations, as it can only be opened by using tools.

### Accessories

- Anti-vibration spring mounting
- Condense water drain socket and plug
- Motor, motor guard, slide rails, belt guard, belt drive
- Bearing, bearing and shaft cover
- Fan and motor support base frame
- Inlet flanges, Inlet sleeve with clamping bands
- Splinter protection cover.

### Optional

- Full range of colour matching
- Flame Retardant
- High Temperature
- Electrostatic Discharge - Anti-static, Static dissipative or Conductive
- Ultra Violet

### Thermal and Chemical resistant

The temperature of the air and gases must not exceed that specified for the materials:

Material	max. Temp. [°C]
PVC	60
PP	80
GFK	100
PVDF	120

Please contact our local sales engineers for detailed list of Chemical Application Information.

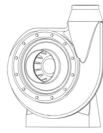

Fan test laboratory AMCA 210/99 Fig.12, Test Chamber. Performance certified is for installation type B-Free inlet, Ducted outlet.

Power rating (kW) does not include transmission losses, Performance ratings do not include the effects of appurtenances (accessories). The A-weighted sound ratings shown have been calculated per AMCA International Standard 301. Values shown are for inlet L<sub>WA</sub> sound power levels for installation Type B: free inlet, ducted outlet.

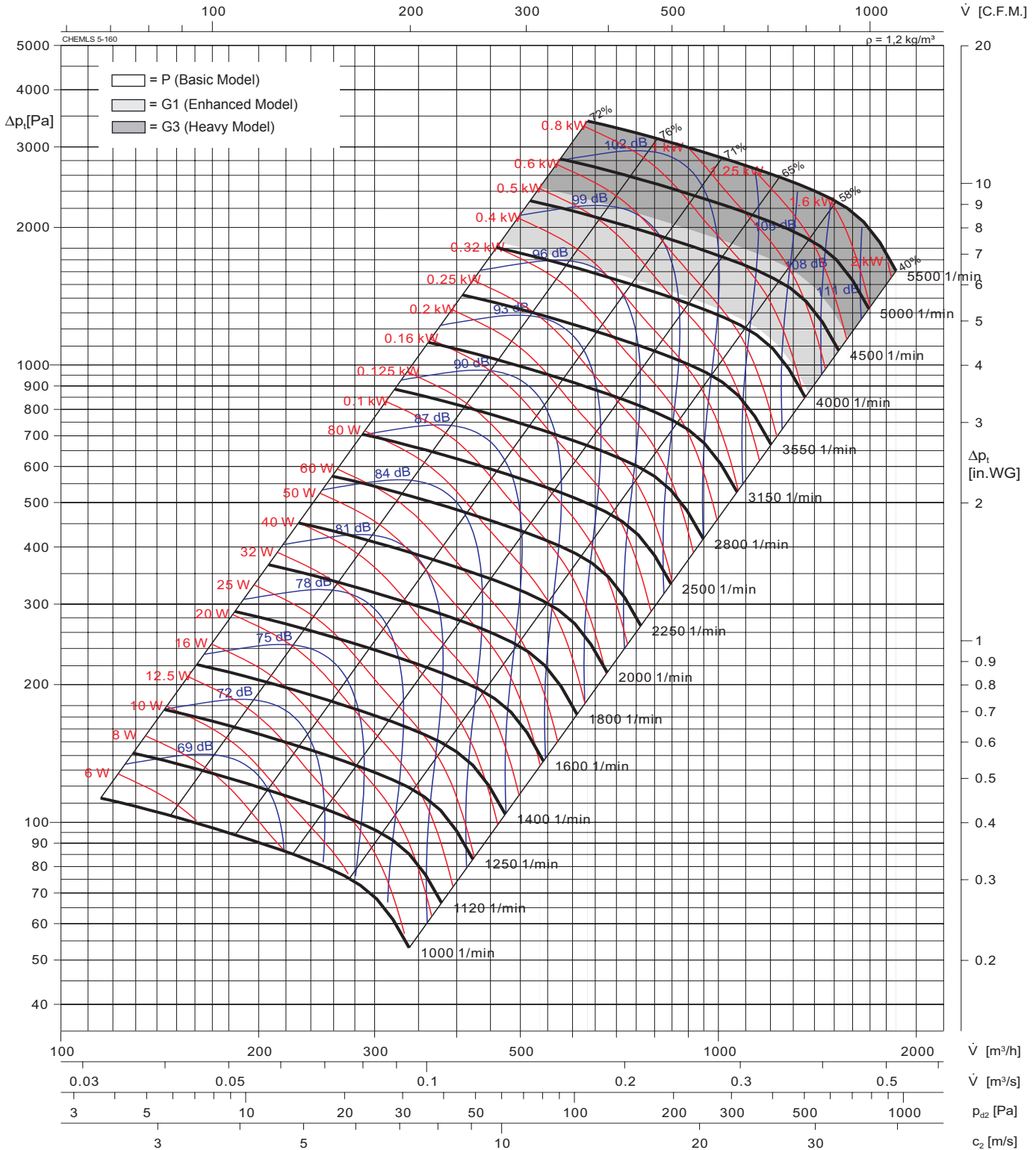

Im Kennfeld ist der A-bewertete Schalleistungspegel  $L_{WA}$  angegeben. A-weighted Sound power level  $L_{WA}$  is quoted in the diagram.

Schalldruckpegel  $L_{PA}$  in 1 m Entfernung A-Sound pressure level  $L_{PA}$  at 1 meter distance

$$L_{PA} [dB(A)] = L_{WA} [dB(A)] - 7 [dB]$$

Oktavpegels  $L_{Wokt}$ : Octave sound power level  $L_{Wokt}$ :

$$L_{Wokt} [dB] = L_{WA} [dB(A)] + \Delta L [dB]$$

**Relative Frequenzspektrum**  
relative frequency spectrum  $\Delta L$  in dB/Okt

n [1/min] rpm	Oktav.-Mittenfrequ. / Octave b. midfreq. [Hz]							
	63	125	250	500	1k	2k	4k	8k
1000 - 2500	-3	-4	-11	-19	-25	-31	-36	-42
2800 - 5500	-6	-3	-6	-14	-21	-28	-33	-38

The test data is obtained in a laboratory registered by AMCA for AMCA 210/99 air performance testing. Data is not certified by AMCA.



Fan test laboratory AMCA 210/99 Fig. 12, Test Chamber. Performance certified is for installation type B-Free inlet, Ducted outlet.

Power rating (kW) does not include transmission losses, Performance ratings do not include the effects of appurtenances (accessories). The A-weighted sound ratings shown have been calculated per AMCA International Standard 301. Values shown are for inlet L<sub>WA</sub> sound power levels for installation Type B: free inlet, ducted outlet.

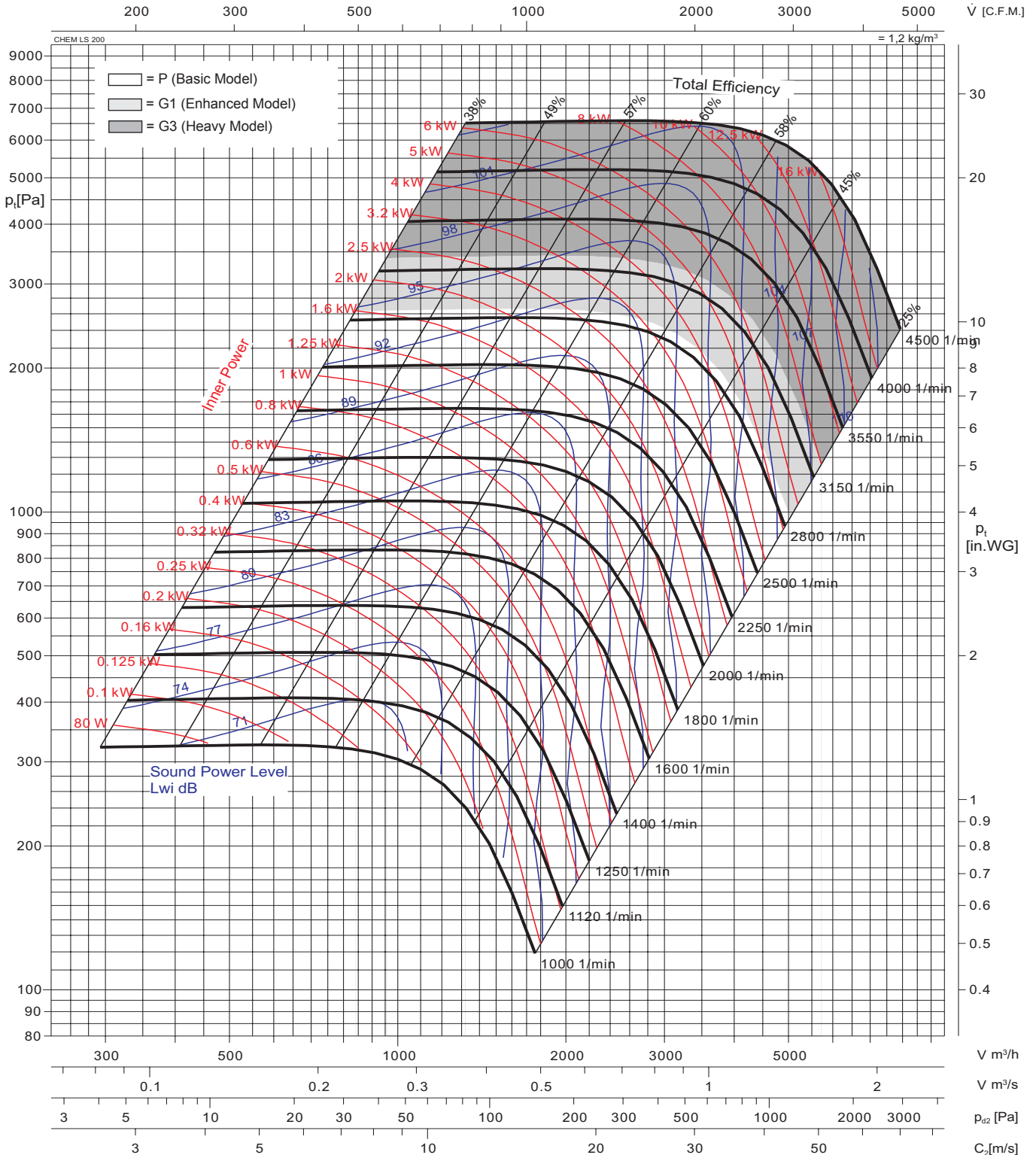

Im Kennfeld ist der A-bewertete Schalleistungspegel  $L_{WA}$  angegeben. A-weighted Sound power level  $L_{WA}$  is quoted in the diagram.

Schalldruckpegel  $L_{PA}$  in 1 m Entfernung A-Sound pressure level  $L_{PA}$  at 1 meter distance

$$L_{PA} [\text{dB(A)}] = L_{WA} [\text{dB(A)}] - 7 [\text{dB}]$$

Oktavpegel  $L_{Wokt}$ : Octave sound power level  $L_{Wokt}$ :

$$L_{Wokt} [\text{dB}] = L_{WA} [\text{dB(A)}] + \Delta L [\text{dB}]$$

**Relative Frequenzspektrum**  
relative frequency spectrum  $\Delta L$  in dB/Okt

n [1/min]	Oktavb.-Mittenfreq. / Octave b. midfreq. [Hz]							
	63	125	250	500	1k	2k	4k	8k
800 - 1800	-2	-6	-14	-21	-27	-32	-38	-44
2000 - 4500	-7	-4	-6	-13	-21	-28	-33	-38

The test data is obtained in a laboratory registered by AMCA for AMCA 210/99 air performance testing. Data is not certified by AMCA.



Fan test laboratory AMCA 210/99 Fig.12, Test Chamber. Performance certified is for installation type B-Free inlet, Ducted outlet.

Power rating (kW) does not include transmission losses, Performance ratings do not include the effects of appurtenances (accessories). The A-weighted sound ratings shown have been calculated per AMCA International Standard 301. Values shown are for inlet LwA sound power levels for installation Type B: free inlet, ducted outlet.

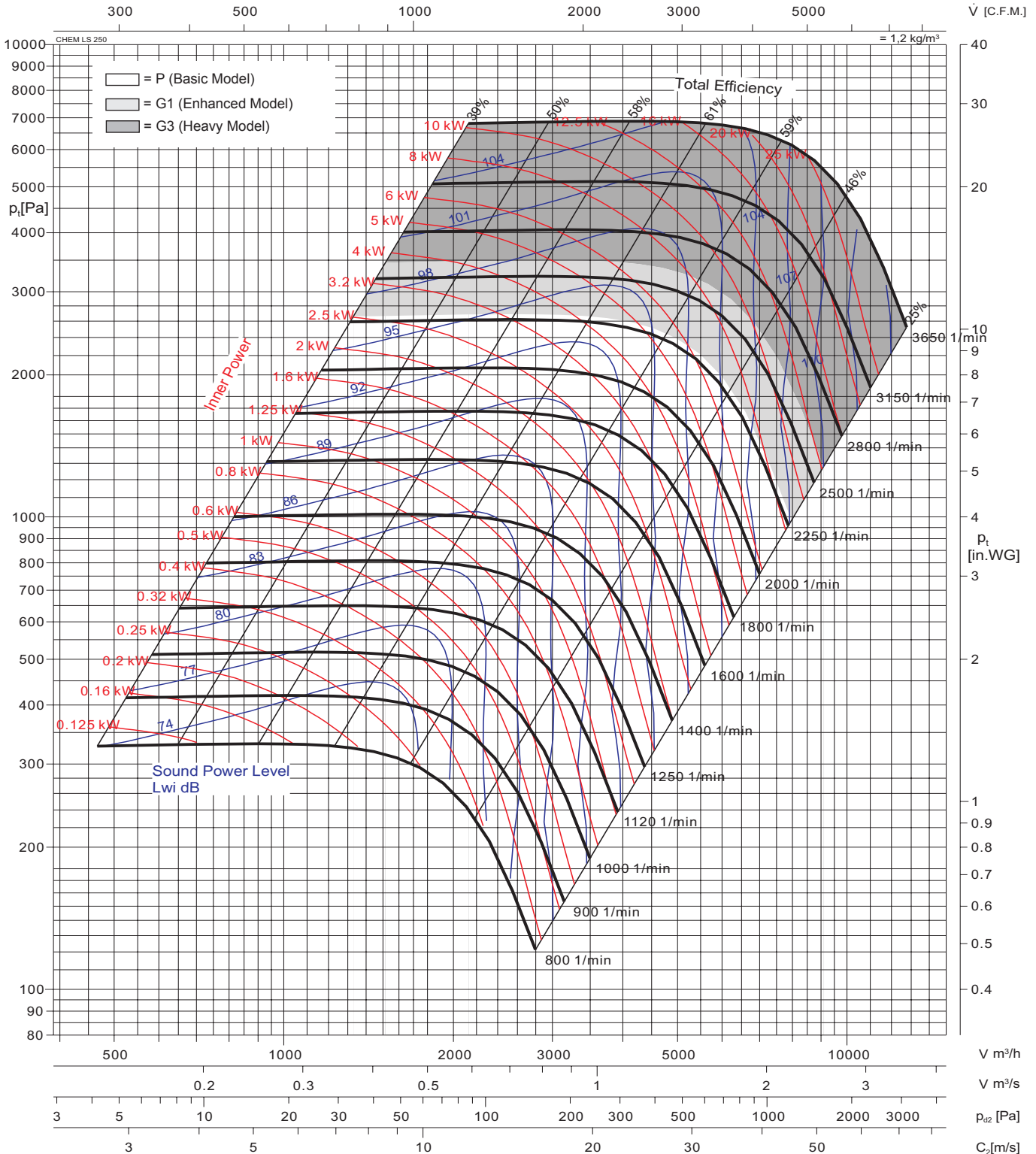

Im Kennfeld ist der A-bewertete Schalleistungspegel  $L_{WA}$  angegeben. A-weighted Sound power level  $L_{WA}$  is quoted in the diagram.

Schalldruckpegel  $L_{PA}$  in 1 m Entfernung A-Sound pressure level  $L_{PA}$  at 1 meter distance

$$L_{PA} [dB(A)] = L_{WA} [dB(A)] - 7 [dB]$$

Oktavpegels  $L_{Wokt}$ : Octave sound power level  $L_{Wokt}$ :

$$L_{Wokt} [dB] = L_{WA} [dB(A)] + \Delta L [dB]$$

Relative Frequenzspektrum  
relative frequency spectrum  $\Delta L$  in dB/Okt

n [1/min] rpm	Oktav.-Mittenfrequ. / Octave b. midfreq. [Hz]							
	63	125	250	500	1k	2k	4k	8k
800 - 1800	-2	-6	-14	-21	-27	-32	-38	-44
2000 - 4500	-4	-3	-10	-18	-25	-30	-36	-41

The test data is obtained in a laboratory registered by AMCA for AMCA 210/99 air performance testing. Data is not certified by AMCA.



Fan test laboratory AMCA 210/99 Fig. 12, Test Chamber. Performance certified is for installation type B-Free inlet, Ducted outlet.

Power rating (kW) does not include transmission losses, Performance ratings do not include the effects of appurtenances (accessories). The A-weighted sound ratings shown have been calculated per AMCA International Standard 301. Values shown are for inlet LwA sound power levels for installation Type B: free inlet, ducted outlet.

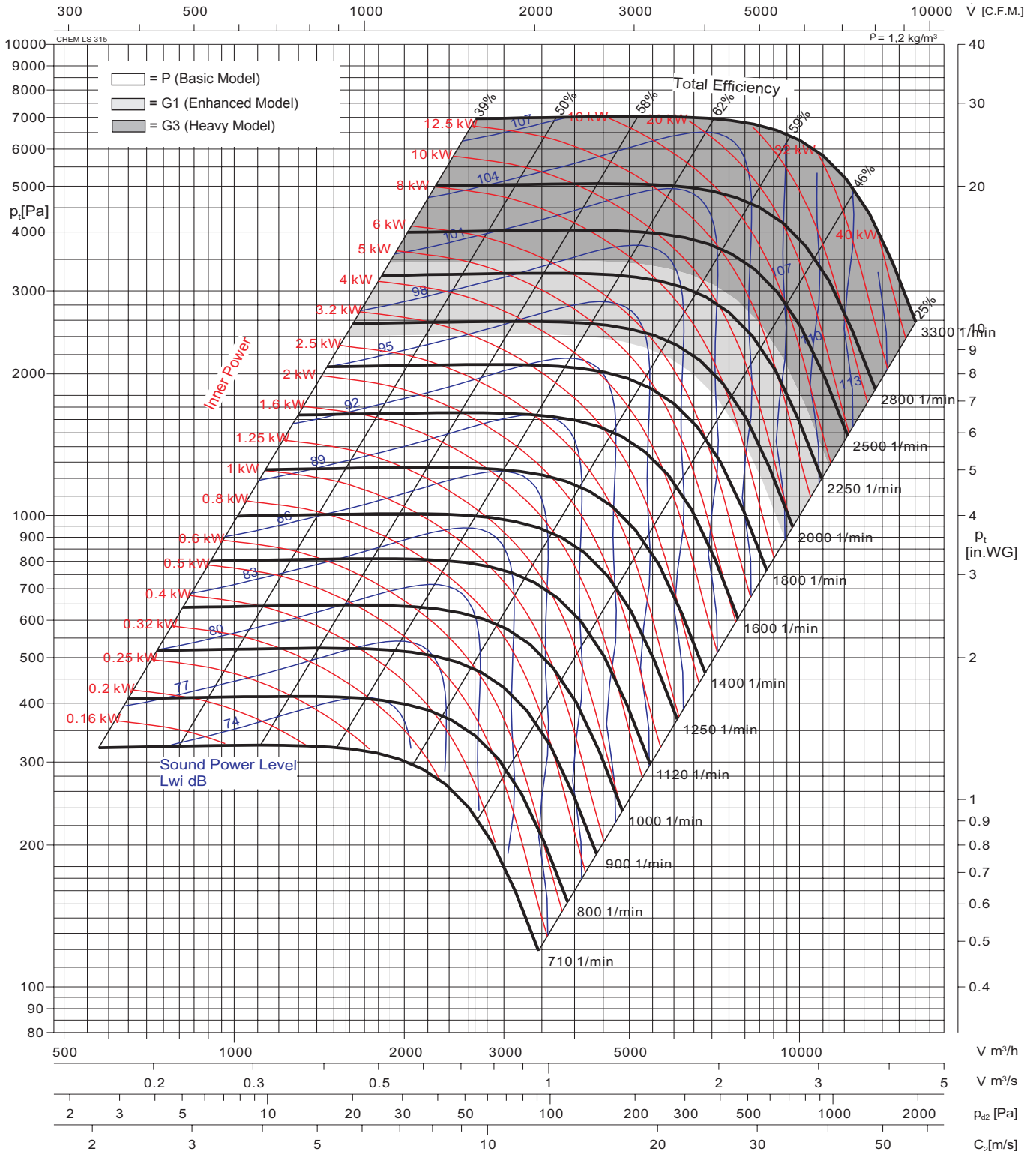

Im Kennfeld ist der A-bewertete Schalleistungspegel  $L_{WA}$  angegeben. A-weighted Sound power level  $L_{WA}$  is quoted in the diagram.

Schalldruckpegel  $L_{PA}$  in 1 m Entfernung A-Sound pressure level  $L_{PA}$  at 1 meter distance

$$L_{PA} [dB(A)] = L_{WA} [dB(A)] - 7 [dB]$$

Oktavpegels  $L_{Wokt}$ : Octave sound power level  $L_{Wokt}$ :

$$L_{Wokt} [dB] = L_{WA} [dB(A)] + \Delta L [dB]$$

**Relative Frequenzspektr**  
relative frequency spectrum  $\Delta L$  in dB/Okt

n [1/min] rpm	Oktavb.-Mittenfreq. / Octave b. midfreq. [Hz]							
	63	125	250	500	1k	2k	4k	8k
710 - 1800	-1	-7	-16	-23	-28	-34	-39	-46
2000 - 3650	-3	-4	-11	-19	-25	-31	-36	-42

The test data is obtained in a laboratory registered by AMCA for AMCA 210/99 air performance testing. Data is not certified by AMCA.



Fan test laboratory AMCA 210/99 Fig.12, Test Chamber. Performance certified is for installation type B-Free inlet, Ducted outlet.

Power rating (kW) does not include transmission losses, Performance ratings do not include the effects of appurtenances (accessories). The A-weighted sound ratings shown have been calculated per AMCA International Standard 301. Values shown are for inlet LwA sound power levels for installation Type B: free inlet, ducted outlet.

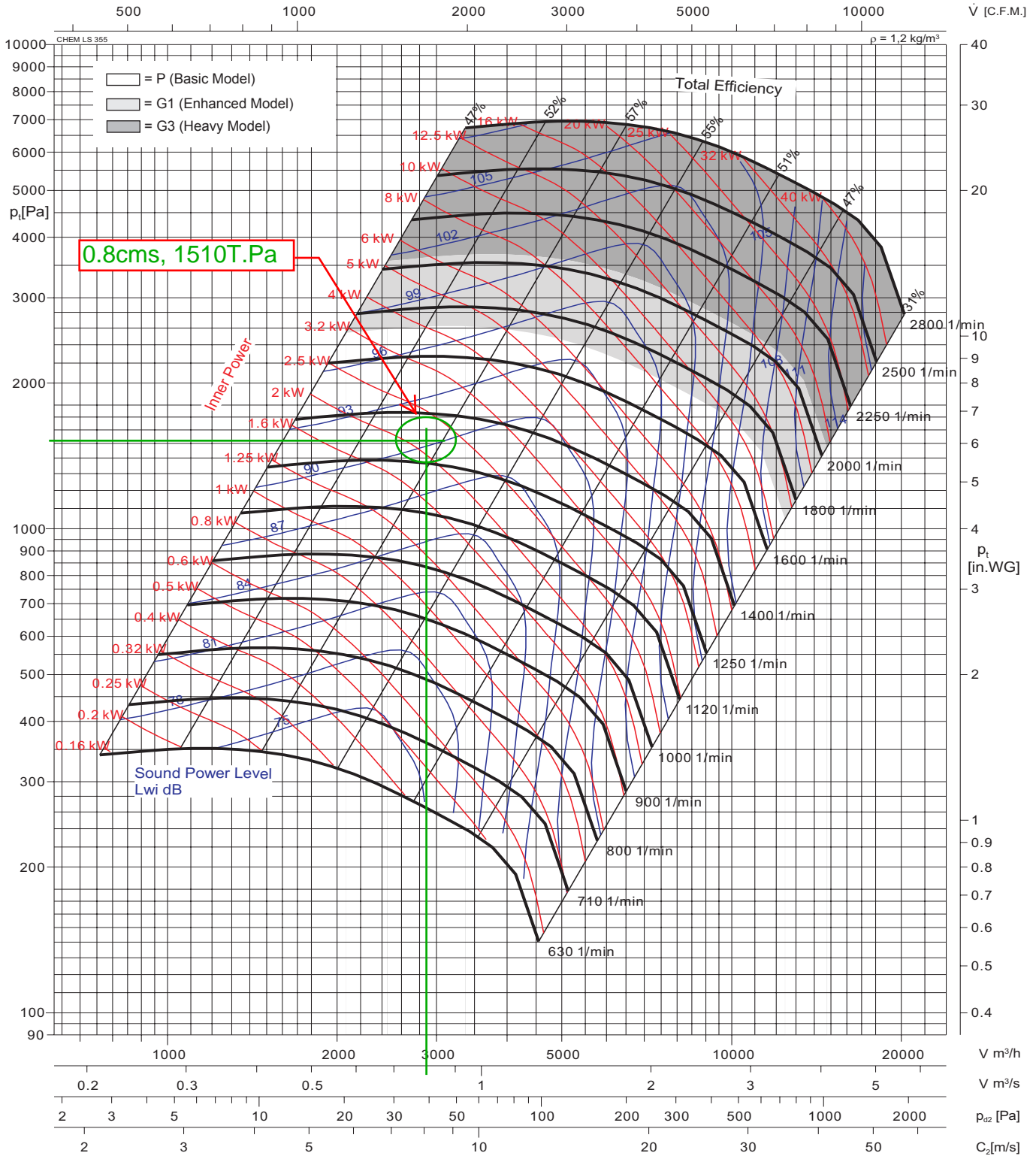

Im Kennfeld ist der A-bewertete Schalleistungspegel  $L_{WA}$  angegeben. A-weighted Sound power level  $L_{WA}$  is quoted in the diagram.

Schalldruckpegel  $L_{PA}$  in 1 m Entfernung A-Sound pressure level  $L_{PA}$  at 1 meter distance

$$L_{PA} [\text{dB(A)}] = L_{WA} [\text{dB(A)}] - 7 [\text{dB}]$$

Oktavpegels  $L_{Wokt}$ : Octave sound power level  $L_{Wokt}$ :

$$L_{Wokt} [\text{dB}] = L_{WA} [\text{dB(A)}] + \Delta L [\text{dB}]$$

Relative Frequenzspektrum  
relative frequency spectrum  $\Delta L$  in dB/Okt

n [1/min] rpm	Oktavb.-Mittenfreq. / Octave b. midfreq. [Hz]							
	63	125	250	500	1k	2k	4k	8k
560 - 1800	-2	-5	-12	-20	-26	-31	-37	-43
2000 - 3350	-6	-3	-8	-17	-24	-30	-35	-40

The test data is obtained in a laboratory registered by AMCA for AMCA 210/99 air performance testing. Data is not certified by AMCA.



Fan test laboratory AMCA 210/99 Fig. 12, Test Chamber. Performance certified is for installation type B-Free inlet, Ducted outlet.

Power rating (kW) does not include transmission losses, Performance ratings do not include the effects of appurtenances (accessories). The A-weighted sound ratings shown have been calculated per AMCA International Standard 301. Values shown are for inlet L<sub>wA</sub> sound power levels for installation Type B: free inlet, ducted outlet.

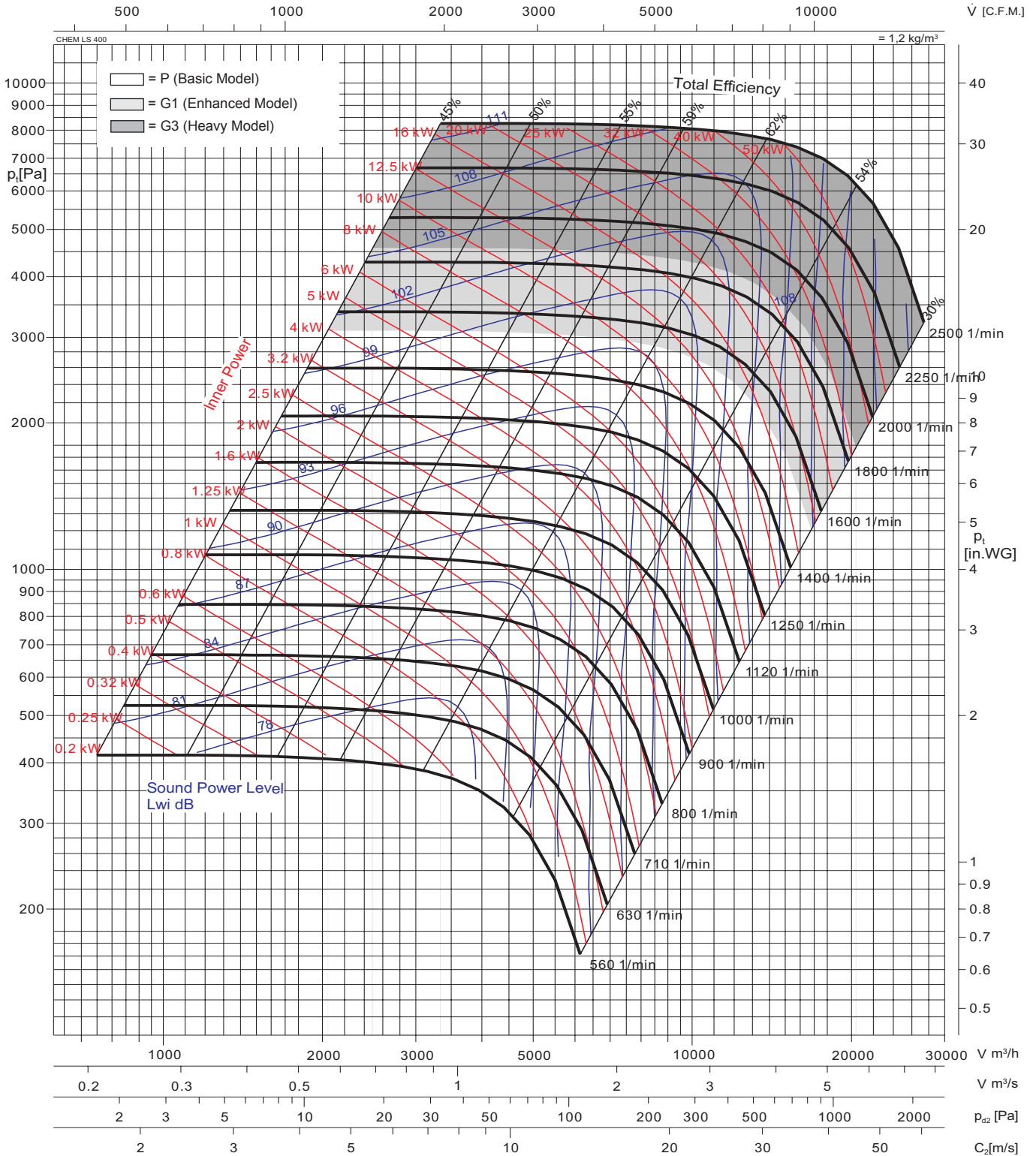

Im Kennfeld ist der A-bewertete Schalleistungspegel  $L_{WA}$  angegeben. A-weighted Sound power level  $L_{WA}$  is quoted in the diagram.

Schalldruckpegel  $L_{PA}$  in 1 m Entfernung A-Sound pressure level  $L_{PA}$  at 1 meter distance

$$L_{PA} [\text{dB(A)}] = L_{WA} [\text{dB(A)}] - 7 [\text{dB}]$$

Oktavpegel  $L_{Wokt}$ : Octave sound power level  $L_{Wokt}$ :

$$L_{Wokt} [\text{dB}] = L_{WA} [\text{dB(A)}] + \Delta L [\text{dB}]$$

Relative Frequenzspektrum relative frequency spectrum  $\Delta L$  in dB/Okt

n [1/min]	Oktavb.-Mittenfreq. / Octave b. midfreq. [Hz]								
	rpm	63	125	250	500	1k	2k	4k	8k
400 - 1000	2,5	-3,0	-1,6	-1,0	-4,3	-11,7	-17,9	-26,7	
1120 - 2250	-2,6	-2,9	-0,1	-2,9	-5,4	-10,3	-18,0	-26,0	

The test data is obtained in a laboratory registered by AMCA for AMCA 210/99 air performance testing. Data is not certified by AMCA.



Fan test laboratory AMCA 210/99 Fig.12, Test Chamber. Performance certified is for installation type B-Free inlet, Ducted outlet.

Power rating (kW) does not include transmission losses, Performance ratings do not include the effects of appurtenances (accessories). The A-weighted sound ratings shown have been calculated per AMCA International Standard 301. Values shown are for inlet LwA sound power levels for installation Type B: free inlet, ducted outlet.

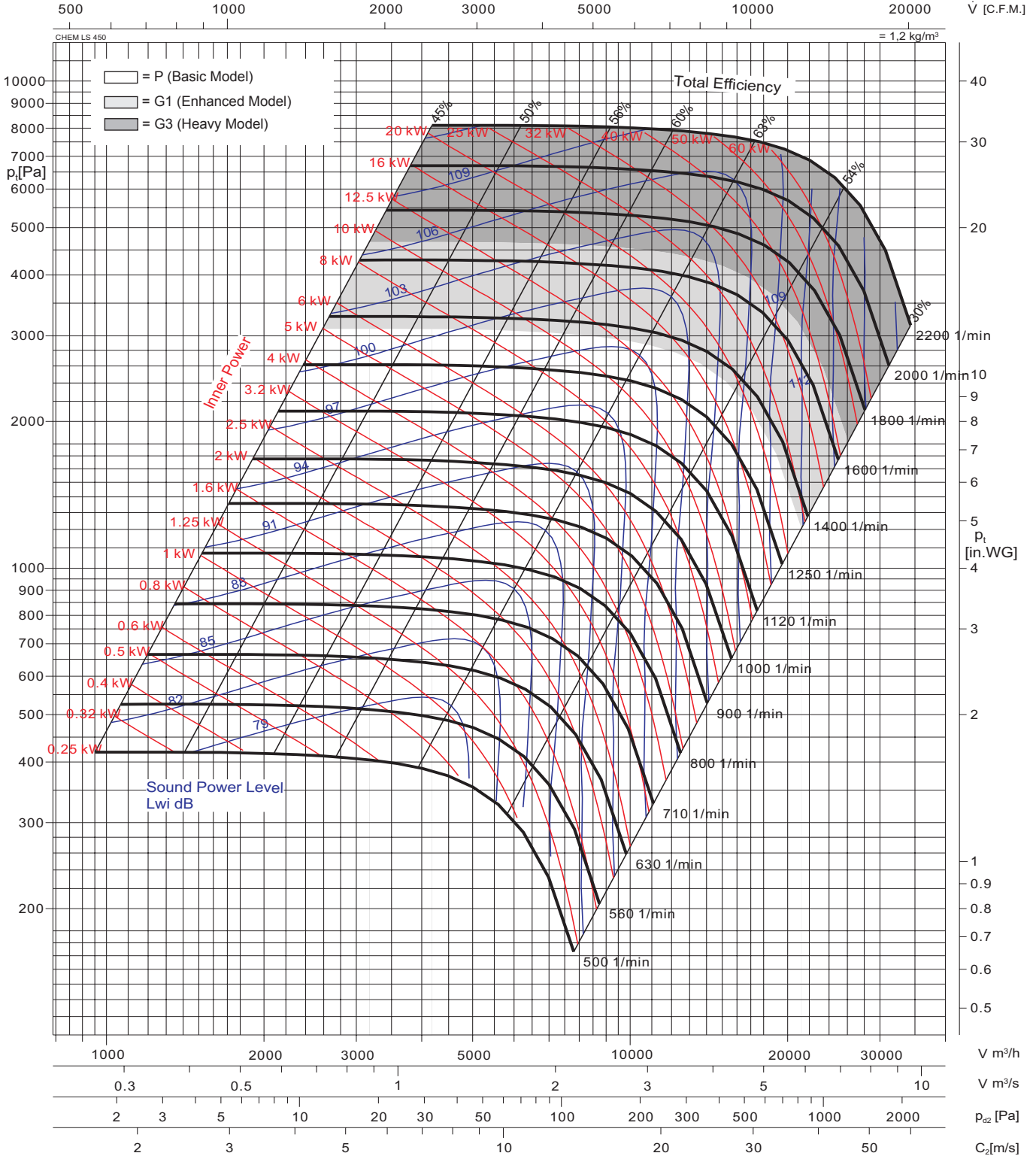

Im Kennfeld ist der A-bewertete Schalleistungspegel  $L_{WA}$  angegeben. A-weighted Sound power level  $L_{WA}$  is quoted in the diagram.

Schalldruckpegel  $L_{PA}$  in 1 m Entfernung A-Sound pressure level  $L_{PA}$  at 1 meter distance

$$L_{PA} [\text{dB(A)}] = L_{WA} [\text{dB(A)}] - 7 [\text{dB}]$$

Oktavpegels  $L_{Wokt}$ : Octave sound power level  $L_{Wokt}$ :

$$L_{Wokt} [\text{dB}] = L_{WA} [\text{dB(A)}] + \Delta L [\text{dB}]$$

Relative Frequenzspektr  
relative frequency spectrum  $\Delta L$  in dB/Okt

n [1/min]	Oktav.-Mittenfrequ. / Octave b. midfreq. [Hz]							
rpm	63	125	250	500	1k	2k	4k	8k

The test data is obtained in a laboratory registered by AMCA for AMCA 210/99 air performance testing. Data is not certified by AMCA.



Fan test laboratory AMCA 210/99 Fig. 12, Test Chamber. Performance certified is for installation type B-Free inlet, Ducted outlet.

Power rating (kW) does not include transmission losses, Performance ratings do not include the effects of appurtenances (accessories). The A-weighted sound ratings shown have been calculated per AMCA International Standard 301. Values shown are for inlet LwA sound power levels for installation Type B: free inlet, ducted outlet.

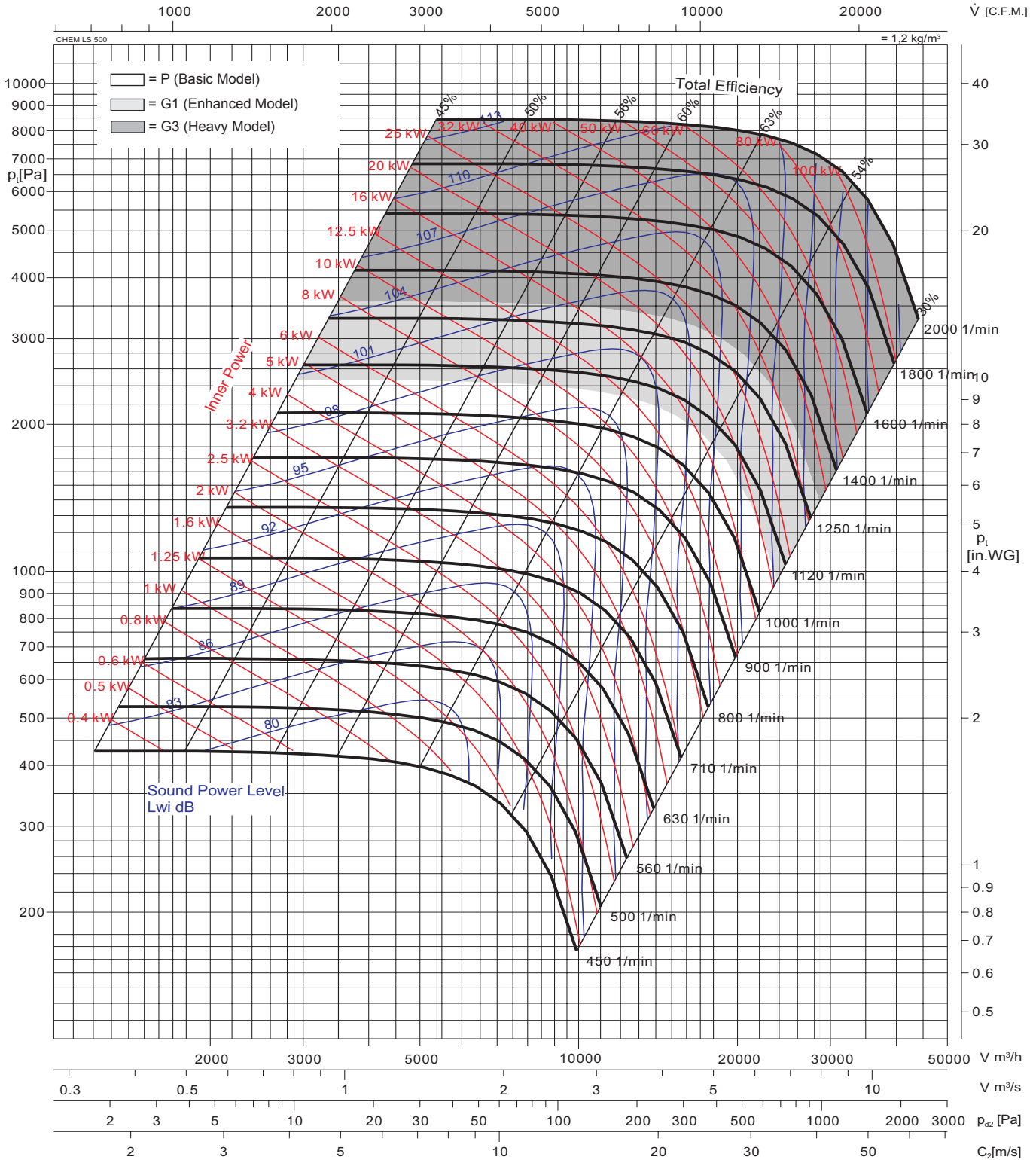

Im Kennfeld ist der A-bewertete Schalleistungspegel  $L_{WA}$  angegeben. A-weighted Sound power level  $L_{WA}$  is quoted in the diagram.

Schalldruckpegel  $L_{PA}$  in 1 m Entfernung A-Sound pressure level  $L_{PA}$  at 1 meter distance

$$L_{PA} [dB(A)] = L_{WA} [dB(A)] - 7 [dB]$$

Oktavpegels  $L_{Wokt}$ : Octave sound power level  $L_{Wokt}$ :

$$L_{Wokt} [dB] = L_{WA} [dB(A)] + \Delta L [dB]$$

**Relative Frequenzspektr**  
relative frequency spectrum  $\Delta L$  in dB/Okt

n [1/min]	Oktavb.-Mittenfrequ. / Octave b. midfreq. [Hz]								
	rpm	63	125	250	500	1k	2k	4k	8k
315 - 800		0,6	-2,2	-0,7	-1,0	-5,6	-12,6	-18,6	-28,5
900 - 1600		-5,4	-1,3	-0,4	-2,5	-3,9	-10,0	-16,8	-26,0

The test data is obtained in a laboratory registered by AMCA for AMCA 210/99 air performance testing. Data is not certified by AMCA.



Fan test laboratory AMCA 210/99 Fig.12, Test Chamber. Performance certified is for installation type B-Free inlet, Ducted outlet.

Power rating (kW) does not include transmission losses, Performance ratings do not include the effects of appurtenances (accessories). The A-weighted sound ratings shown have been calculated per AMCA International Standard 301. Values shown are for inlet LwA sound power levels for installation Type B: free inlet, ducted outlet.

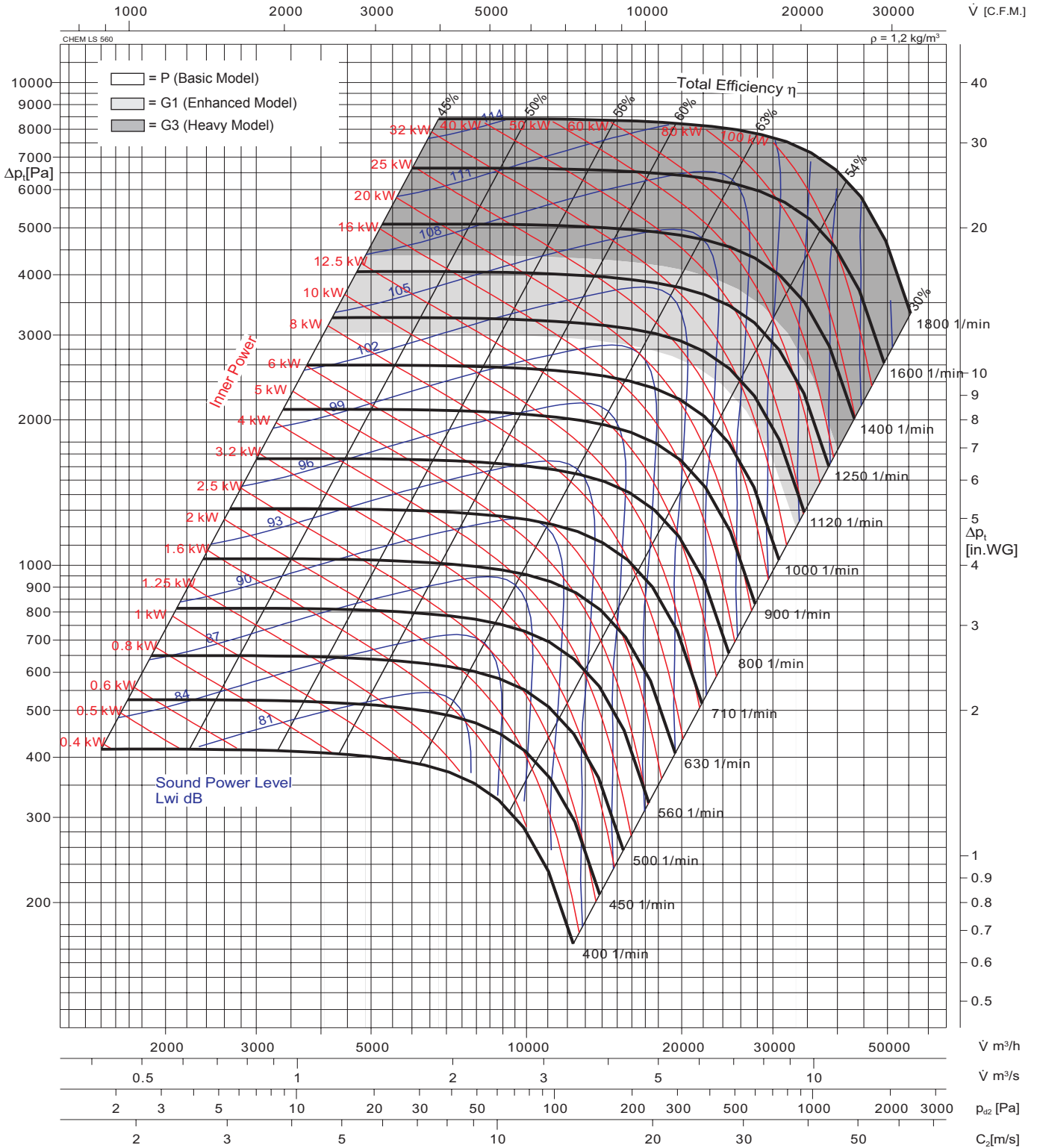

Im Kennfeld ist der A-bewertete Schalleistungspegel  $L_{WA}$  angegeben. A-weighted Sound power level  $L_{WA}$  is quoted in the diagram.

Schalldruckpegel  $L_{PA}$  in 1 m Entfernung A-Sound pressure level  $L_{PA}$  at 1 meter distance

$$L_{PA} [\text{dB(A)}] = L_{WA} [\text{dB(A)}] - 7 [\text{dB}]$$

Oktavpegels  $L_{Wokt}$ : Octave sound power level  $L_{Wokt}$ :

$$L_{Wokt} [\text{dB}] = L_{WA} [\text{dB(A)}] + \Delta L [\text{dB}]$$

Relative Frequenzspektrum  
relative frequency spectrum  $\Delta L$  in dB/Okt

n [1/min] rpm	Oktav.-Mittenfrequ. / Octave b. midfreq. [Hz]							
	63	125	250	500	1k	2k	4k	8k
400 - 1000	-1	-7	-16	-23	-28	-34	-39	-46
1120 - 1800	-1	-8	-16	-22	-28	-33	-39	-46

The test data is obtained in a laboratory registered by AMCA for AMCA 210/99 air performance testing. Data is not certified by AMCA.



Fan test laboratory AMCA 210/99 Fig. 12, Test Chamber. Performance certified is for installation type B-Free inlet, Ducted outlet.

Power rating (kW) does not include transmission losses, Performance ratings do not include the effects of appurtenances (accessories). The A-weighted sound ratings shown have been calculated per AMCA International Standard 301. Values shown are for inlet L<sub>WA</sub> sound power levels for installation Type B: free inlet, ducted outlet.

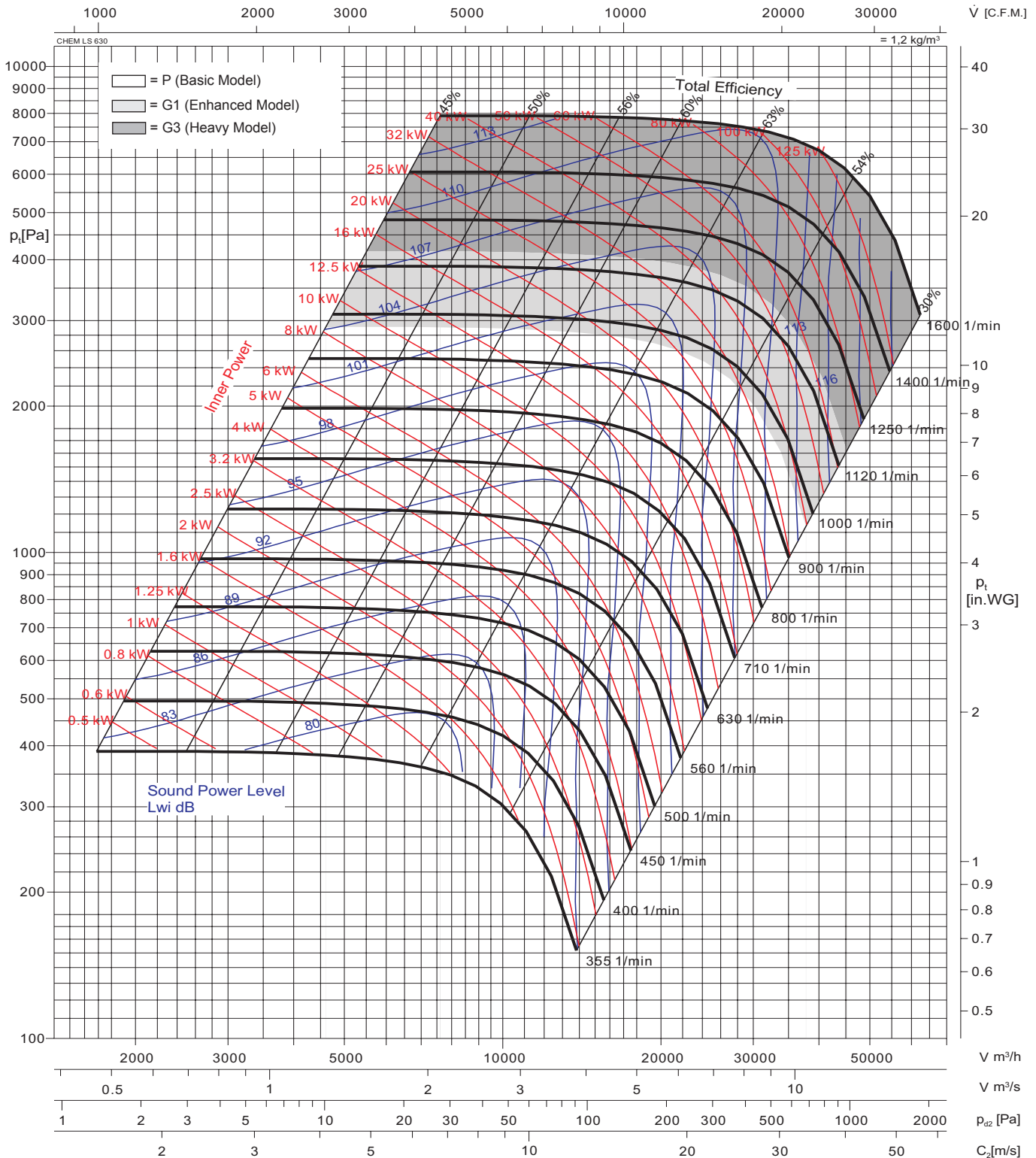

Im Kennfeld ist der A-bewertete Schalleistungspegel  $L_{WA}$  angegeben.

A-weighted Sound power level  $L_{WA}$  is quoted in the diagram.

Schalldruckpegel  $L_{PA}$  in 1 m Entfernung

A-Sound pressure level  $L_{PA}$  at 1 meter distance

$$L_{PA} [dB(A)] = L_{WA} [dB(A)] - 7 [dB]$$

Oktavpegels  $L_{Wokt}$ :

Octave sound power level  $L_{Wokt}$ :

$$L_{Wokt} [dB] = L_{WA} [dB(A)] + \Delta L [dB]$$

**Relative Frequenzspektr**  
relative frequency spectrum  $\Delta L$  in dB/Okt

n [1/min] rpm	Oktavb.-Mittenfreq. / Octave b. midfreq. [Hz]							
	63	125	250	500	1k	2k	4k	8k

The test data is obtained in a laboratory registered by AMCA for AMCA 210/99 air performance testing. Data is not certified by AMCA.

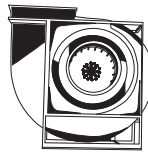

Fan test laboratory AMCA 210/99 Fig.12, Test Chamber. Performance certified is for installation type B-Free inlet, Ducted outlet.

Power rating (kW) does not include transmission losses, Performance ratings do not include the effects of appurtenances (accessories). The A-weighted sound ratings shown have been calculated per AMCA International Standard 301. Values shown are for inlet LwA sound power levels for installation Type B: free inlet, ducted outlet.

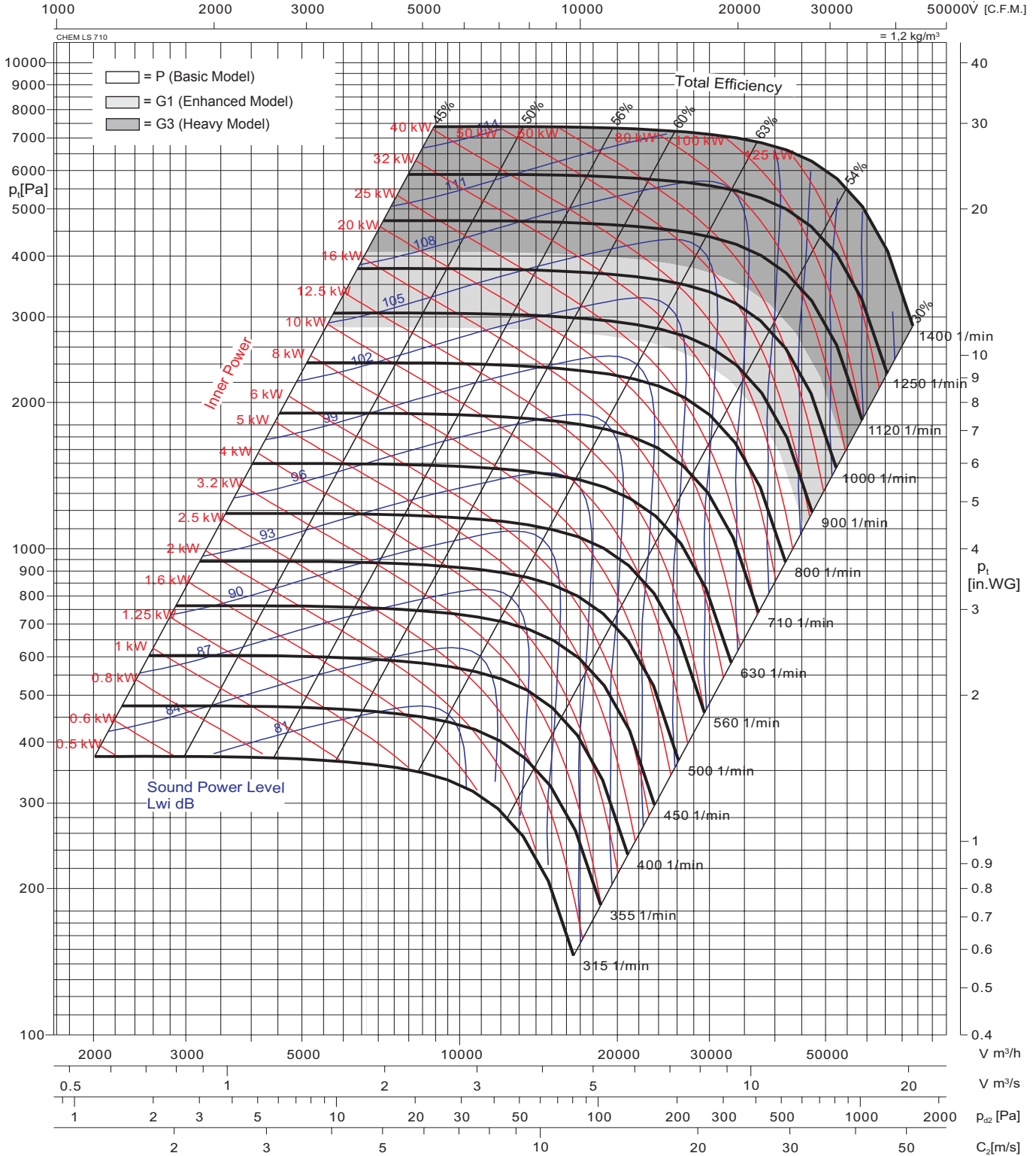

Im Kennfeld ist der A-bewertete Schalleistungspegel  $L_{WA}$  angegeben. A-weighted Sound power level  $L_{WA}$  is quoted in the diagram.

Schalldruckpegel  $L_{PA}$  in 1 m Entfernung A-Sound pressure level  $L_{PA}$  at 1 meter distance

$$L_{PA} [\text{dB(A)}] = L_{WA} [\text{dB(A)}] - 7 [\text{dB}]$$

Oktavpegels  $L_{Wokt}$ : Octave sound power level  $L_{Wokt}$ :

$$L_{Wokt} [\text{dB}] = L_{WA} [\text{dB(A)}] + \Delta L [\text{dB}]$$

Relative Frequenzspektr  
relative frequency spectrum  $\Delta L$  in dB/Okt

n [1/min]	Oktav.-Mittenfrequ. / Octave b. midfreq. [Hz]							
rpm	63	125	250	500	1k	2k	4k	8k

The test data is obtained in a laboratory registered by AMCA for AMCA 210/99 air performance testing. Data is not certified by AMCA.

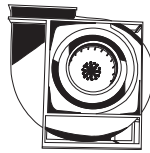

Fan test laboratory AMCA 210/99 Fig. 12, Test Chamber. Performance certified is for installation type B-Free inlet, Ducted outlet.

Power rating (kW) does not include transmission losses, Performance ratings do not include the effects of appurtenances (accessories). The A-weighted sound ratings shown have been calculated per AMCA International Standard 301. Values shown are for inlet L<sub>WA</sub> sound power levels for installation Type B: free inlet, ducted outlet.

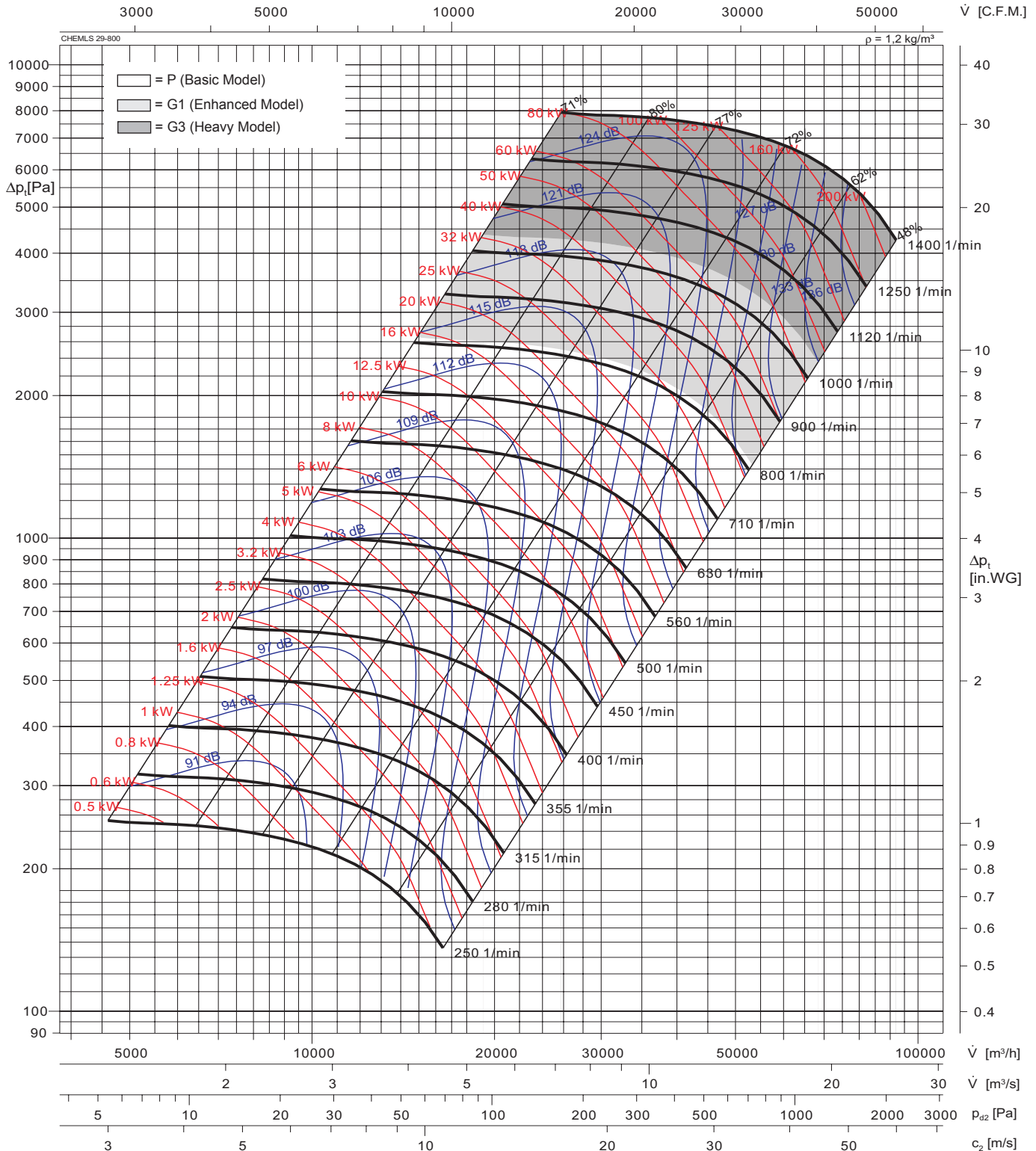

Im Kennfeld ist der A-bewertete Schalleistungspegel  $L_{WA}$  angegeben. A-weighted Sound power level  $L_{WA}$  is quoted in the diagram.

Schalldruckpegel  $L_{PA}$  in 1 m Entfernung A-Sound pressure level  $L_{PA}$  at 1 meter distance

$$L_{PA} [dB(A)] = L_{WA} [dB(A)] - 7 [dB]$$

Oktavpegels  $L_{Wokt}$ : Octave sound power level  $L_{Wokt}$ :

$$L_{Wokt} [dB] = L_{WA} [dB(A)] + \Delta L [dB]$$

**Relative Frequenzspektrum**  
 relative frequency spectrum  $\Delta L$  in dB/Okt

n [1/min]	Oktavb.-Mittenfrequ. / Octave b. midfreq. [Hz]								
	rpm	63	125	250	500	1k	2k	4k	8k

The test data is obtained in a laboratory registered by AMCA for AMCA 210/99 air performance testing. Data is not certified by AMCA.

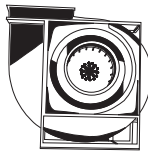

Fan test laboratory AMCA 210/99 Fig.12, Test Chamber. Performance certified is for installation type B-Free inlet, Ducted outlet.

Power rating (kW) does not include transmission losses, Performance ratings do not include the effects of appurtenances (accessories). The A-weighted sound ratings shown have been calculated per AMCA International Standard 301. Values shown are for inlet L<sub>WA</sub> sound power levels for installation Type B: free inlet, ducted outlet.

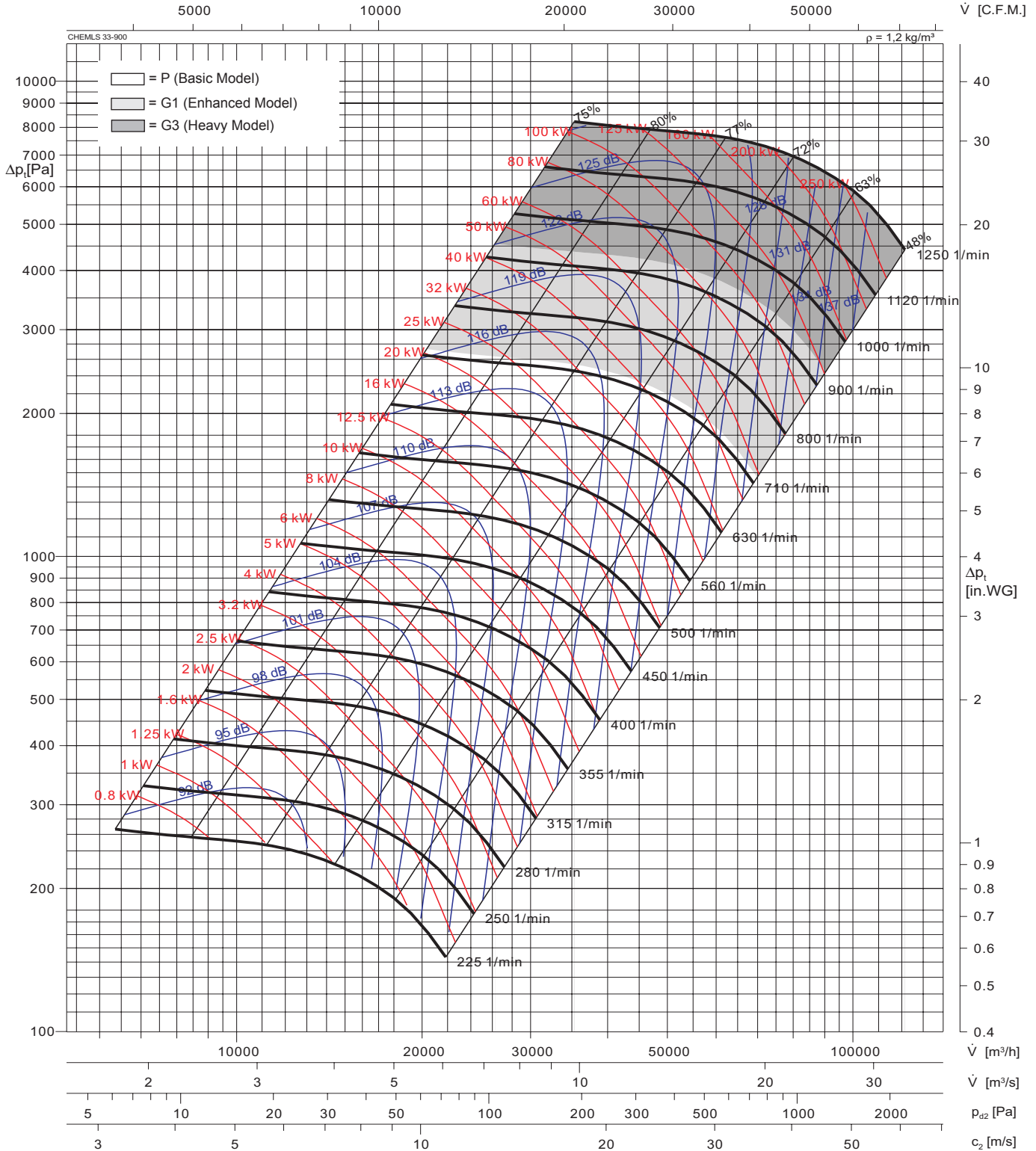

Im Kennfeld ist der A-bewertete Schalleistungspegel  $L_{WA}$  angegeben. A-weighted Sound power level  $L_{WA}$  is quoted in the diagram.

Schalldruckpegel  $L_{PA}$  in 1 m Entfernung A-Sound pressure level  $L_{PA}$  at 1 meter distance

$$L_{PA} \text{ [dB(A)]} = L_{WA} \text{ [dB(A)]} - 7 \text{ [dB]}$$

Oktavpegels  $L_{Wokt}$ : Octave sound power level  $L_{Wokt}$ :

$$L_{Wokt} \text{ [dB]} = L_{WA} \text{ [dB(A)]} + \Delta L \text{ [dB]}$$

**Relative Frequenzspektr**  
 relative frequency spectrum  $\Delta L$  in dB/Okt

n [1/min]	Oktav.-Mittenfrequ. / Octave b. midfreq. [Hz]							
rpm	63	125	250	500	1k	2k	4k	8k

The test data is obtained in a laboratory registered by AMCA for AMCA 210/99 air performance testing. Data is not certified by AMCA.

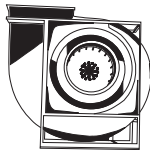

Fan test laboratory AMCA 210/99 Fig. 12, Test Chamber. Performance certified is for installation type B-Free inlet, Ducted outlet.

Power rating (kW) does not include transmission losses, Performance ratings do not include the effects of appurtenances (accessories). The A-weighted sound ratings shown have been calculated per AMCA International Standard 301. Values shown are for inlet L<sub>WA</sub> sound power levels for installation Type B: free inlet, ducted outlet.

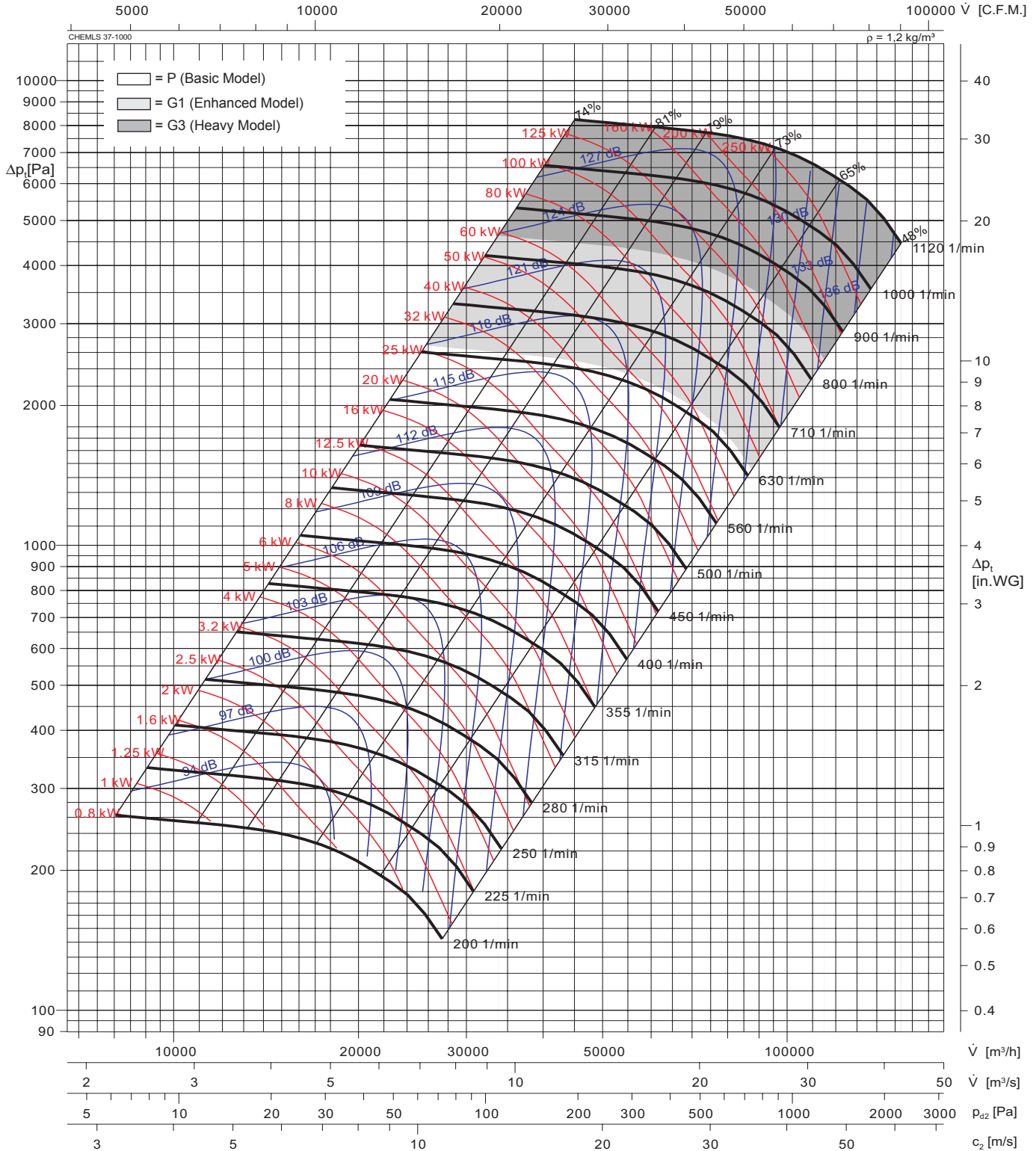

Im Kennfeld ist der A-bewertete Schalleistungspegel  $L_{WA}$  angegeben. A-weighted Sound power level  $L_{WA}$  is quoted in the diagram.

Schalldruckpegel  $L_{PA}$  in 1 m Entfernung A-Sound pressure level  $L_{PA}$  at 1 meter distance

$$L_{PA} [dB(A)] = L_{WA} [dB(A)] - 7 [dB]$$

Oktavpegel  $L_{Wokt}$ : Octave sound power level  $L_{Wokt}$ :

$$L_{Wokt} [dB] = L_{WA} [dB(A)] + \Delta L [dB]$$

Relative Frequenzspektrum relative frequency spectrum  $\Delta L$  in dB/Okt

n [1/min] rpm	Oktavb.-Mittenfrequ. / Octave b. midfreq. [Hz]							
	63	125	250	500	1k	2k	4k	8k

The test data is obtained in a laboratory registered by AMCA for AMCA 210/99 air performance testing. Data is not certified by AMCA.

### CHEM LS 125-160 PP

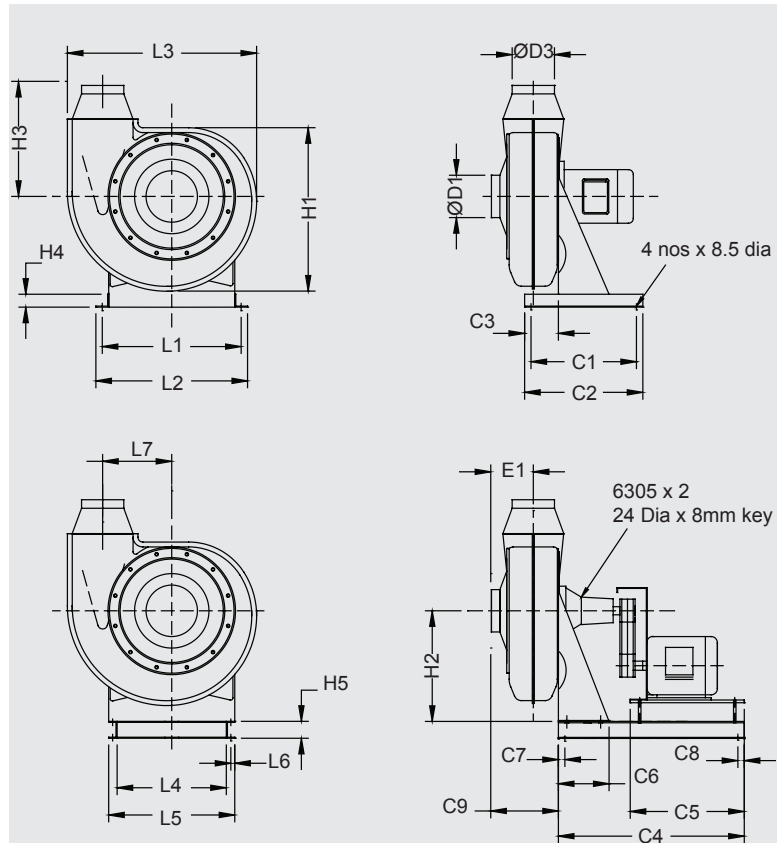

Drehrichtung von Antriebsseite aus gesehen  
 G = Gewicht des nackten Ventilators ohne Antrieb  
 The direction of rotation is as viewed from the drive side  
 G = Barefan weight approximatly

Größe	C1	C2	C3	C4	C5	C6	C7	C8	C9	D1	D2	D3	D4	E1
size	[mm]	[mm]	[mm]	[mm]	[mm]	[mm]	[mm]	[mm]	[mm]	[mm]	[mm]	[mm]	[mm]	[mm]
125	282	320	100	475	300	128	19	19	176	127	-	127	-	100
160	300	350	100	550	338	150	25	25	203	154	-	154	-	124

  

Größe	H1	H2a	H2b	H3	H4	H5	L1	L2	L3	L4	L5	L6	L7	G
size	[mm]	[mm]	[mm]	[mm]	[mm]	[mm]	[mm]	[mm]	[mm]	[mm]	[mm]	[mm]	[mm]	[kg]
125	429	291	496	315	20	50	370	408	498	282	332	12	182	32
160	537	364	500	414	20	50	453	491	622	365	415	12	227	44

Maß- und Konstruktionsänderungen, dem technischen Fortschritt dienend, bleiben uns vorbehalten.  
 We reserve the right to alter measurements without notice in case of technical improvements

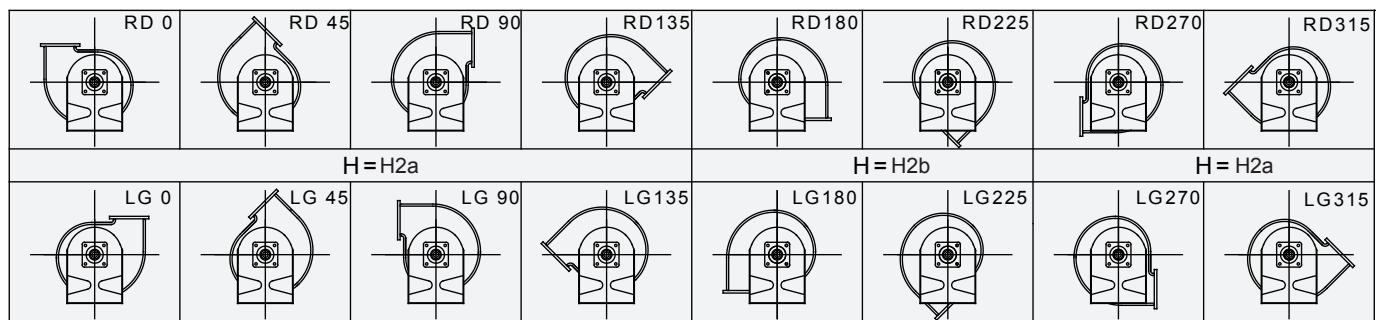

## CHEM LS 200-250 GRP

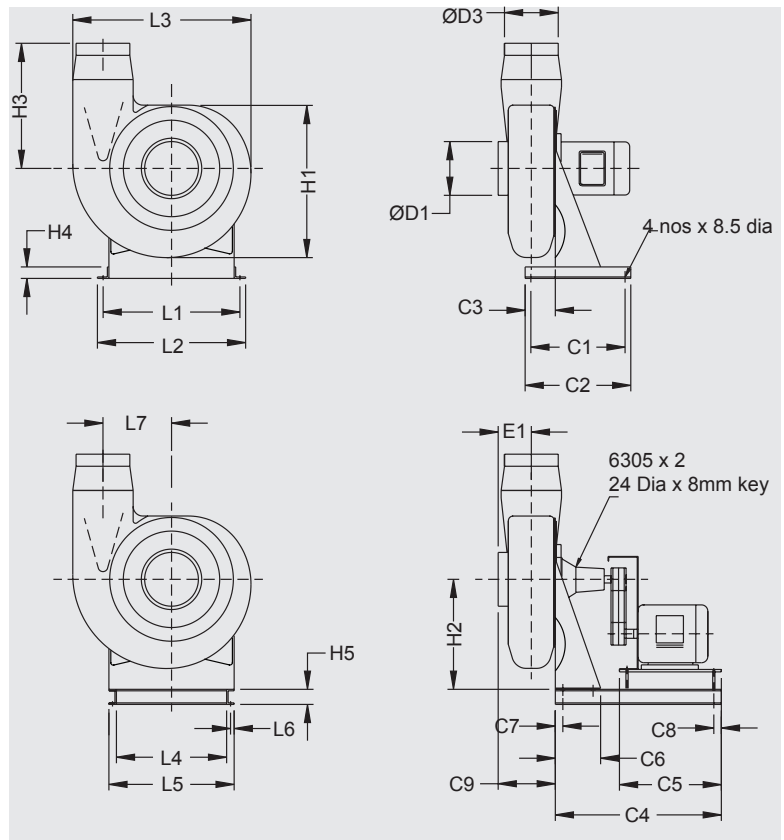

Drehrichtung von Antriebsseite aus gesehen  
 G = Gewicht des nackten Ventilators ohne Antrieb  
 The direction of rotation is as viewed from the drive side  
 G = Barefan weight approximatly

Größe	C1	C2	C3	C4	C5	C6	C7	C8	C9	D1	D2	D3	D4	E1
size	[mm]	[mm]	[mm]	[mm]	[mm]	[mm]	[mm]	[mm]	[mm]	[mm]	[mm]	[mm]	[mm]	[mm]
200	300	350	100	600	400	150	25	25	210	200	-	200	-	121
250	350	400	125	650	450	150	25	25	245	250	-	250	-	142

  

Größe	H1	H2a	H2b	H3	H4	H5	L1	L2	L3	L4	L5	L6	L7	G
size	[mm]	[mm]	[mm]	[mm]	[mm]	[mm]	[mm]	[mm]	[mm]	[mm]	[mm]	[mm]	[mm]	[kg]
200	631	454	633	491	30	75	568	618	737	442	518	19	284	58
250	795	530	720	614	50	75	659	709	930	533	609	19	358	78

Maß- und Konstruktionsänderungen, dem technischen Fortschritt dienend, bleiben uns vorbehalten.  
 We reserve the right to alter measurements without notice in case of technical improvements

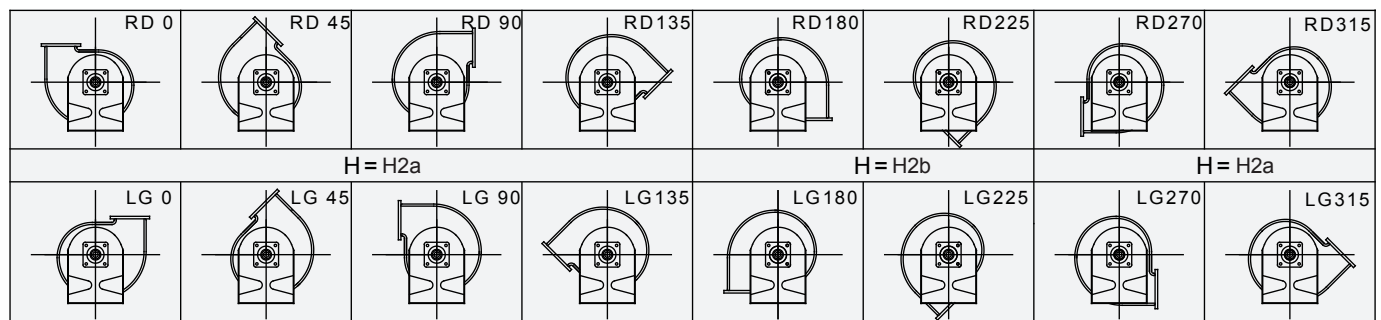

## CHEM LS 315 GRP

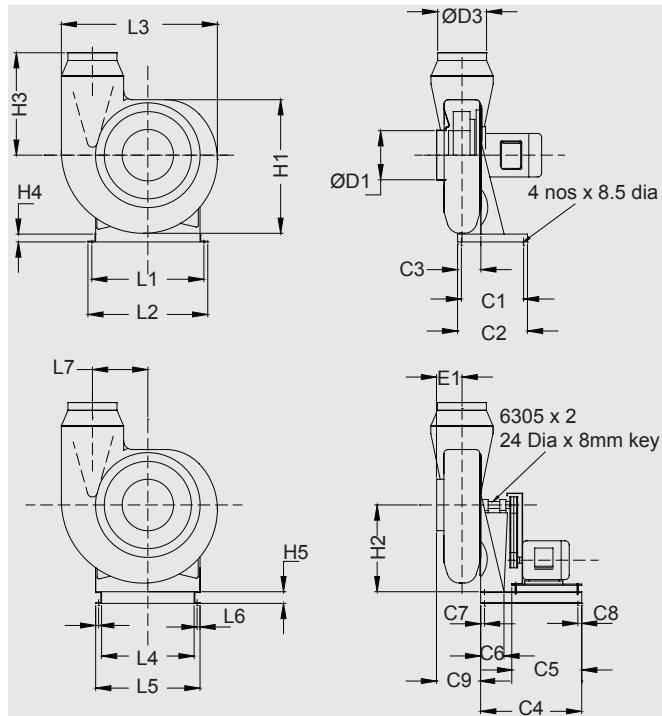

## CHEM LS 355 GRP

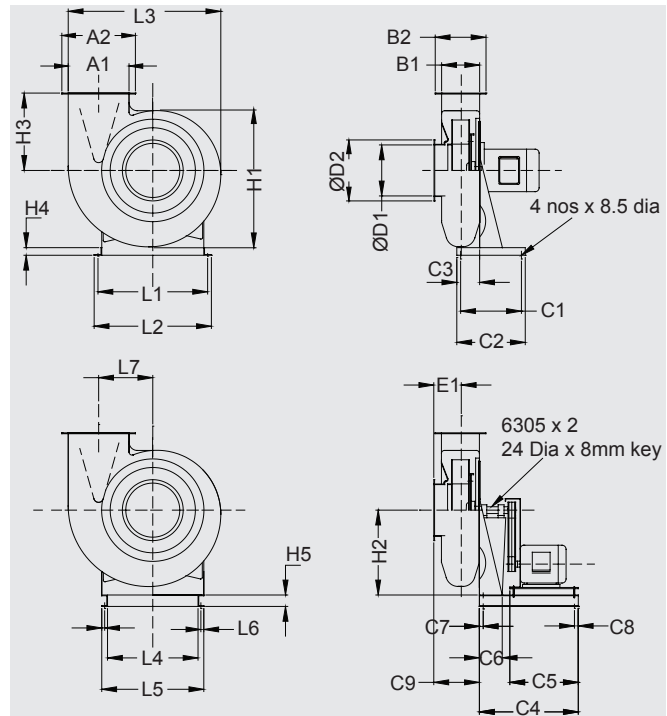

Drehrichtung von Antriebsseite aus gesehen

G = Gewicht des nackten Ventilators ohne Antrieb

The direction of rotation is as viewed from the drive side

G = Barefan weight approximatly

Größe	A1	A2	B1	B2	C1	C2	C3	C4	C5	C6	C7	C8	C9	D1	D2	D3
size	[mm]	[mm]	[mm]	[mm]	[mm]	[mm]	[mm]	[mm]	[mm]	[mm]	[mm]	[mm]	[mm]	[mm]	[mm]	[mm]
315	-	-	-	-	400	450	150	650	450	150	25	25	285	315	-	315
355	400	484	250	334	400	450	150	650	450	150	25	25	285	335	400	-

Größe	D4	E1	H1	H2a	H2b	H3	H4	H5	L1	L2	L3	L4	L5	L6	L7	G
size	[mm]	[mm]	[mm]	[mm]	[mm]	[mm]	[mm]	[mm]	[mm]	[mm]	[mm]	[mm]	[mm]	[mm]	[mm]	[mm]
315	-	166	858	557	750	658	50	75	721	771	1003	595	671	19	356	108
355	-	181	893	557	750	508	50	75	721	771	1003	595	671	19	356	121

Maß- und Konstruktionsänderungen, dem technischen Fortschritt dienend, bleiben uns vorbehalten.

We reserve the right to alter measurements without notice in case of technical improvements

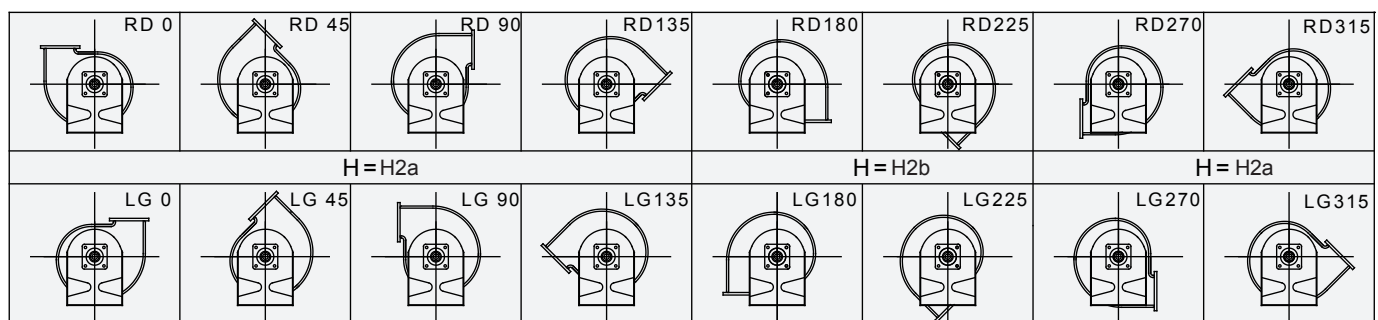

## CHEM LS 400-630 GRP

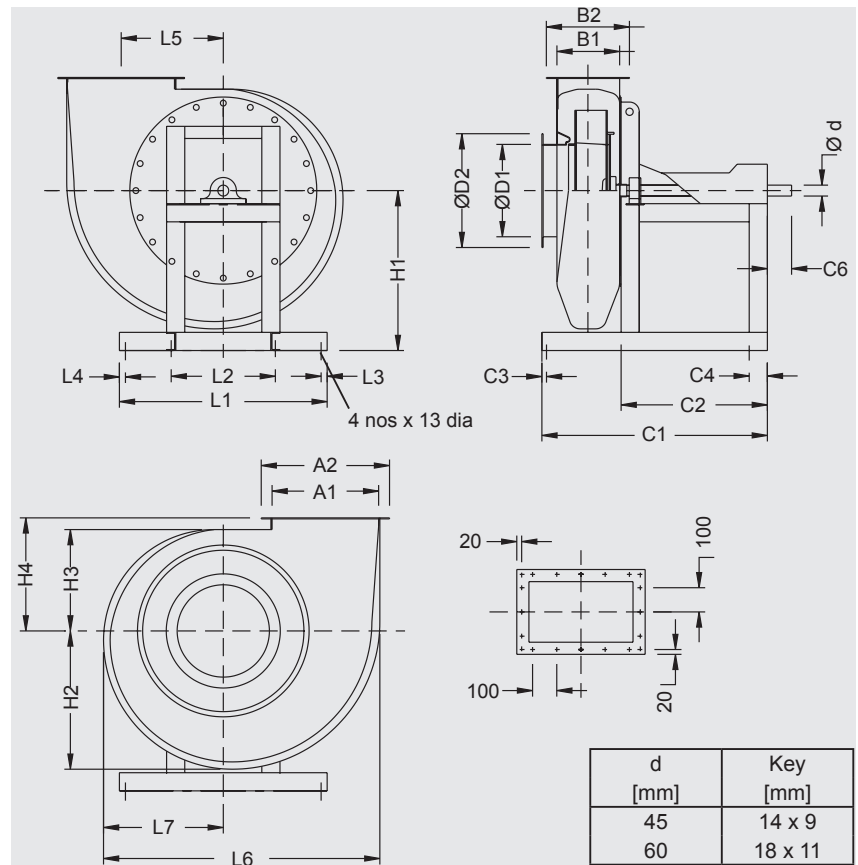

Drehrichtung von Antriebsseite aus gesehen  
 G = Gewicht des nackten Ventilators ohne Antrieb  
 The direction of rotation is as viewed from the drive side  
 G = Barefan weight approximately

Größe size	A1 [mm]	A2 [mm]	B1 [mm]	B2 [mm]	C1 [mm]	C2 [mm]	C3 [mm]	C4 [mm]	C6 [mm]	D1 [mm]	D2 [mm]	d [mm]	H1a [mm]	H1b [mm]
400	440	530	287	387	977	604	19	75	100	400	490	45	685	598
450	490	590	325	425	1013	604	19	75	100	450	540	45	783	633
500	550	650	357	457	1058	604	19	75	125	500	600	45	870	709
560	620	720	397	497	1332	761	19	75	125	560	660	60	939	775
630	710	810	439	539	1332	761	19	75	125	630	730	60	1030	900

  

Größe size	H1c [mm]	H1d [mm]	H1e [mm]	H2 [mm]	H3 [mm]	H4 [mm]	L1 [mm]	L2 [mm]	L3 [mm]	L4 [mm]	L5 [mm]	L6 [mm]	L7 [mm]	G [kg]
400	TBA	800	700	571	418	467	858	430	25	25	448	1210	494	163
450	TBA	911	786	634	465	518	970	448	25	25	570	1360	549	198
500	TBA	1005	879	710	521	580	1090	573	25	25	630	1520	615	240
560	TBA	1128	950	799	586	653	1222	507	25	25	705	1720	692	283
630	TBA	1250	1110	900	660	736	1273	573	25	25	795	1930	780	296

Maß- und Konstruktionsänderungen, dem technischen Fortschritt dienend, bleiben uns vorbehalten.  
 We reserve the right to alter measurements without notice in case of technical improvements

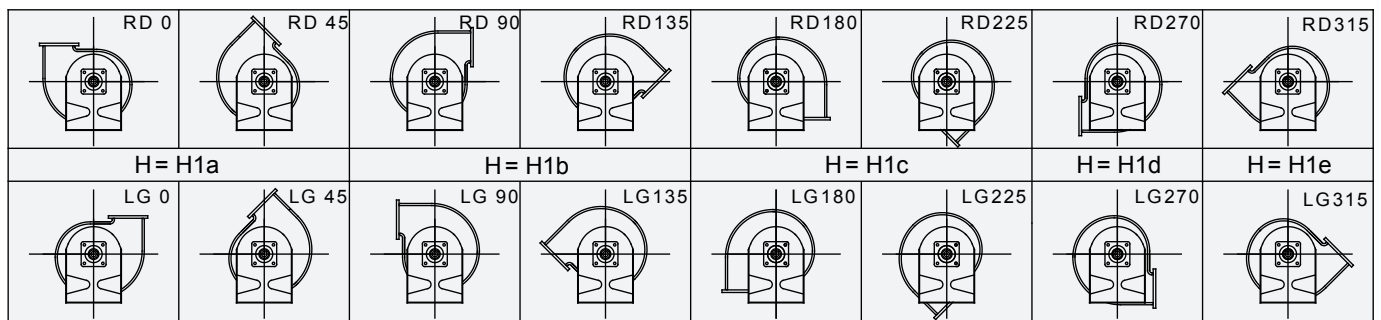

### CHEM LS 710-1000 GRP

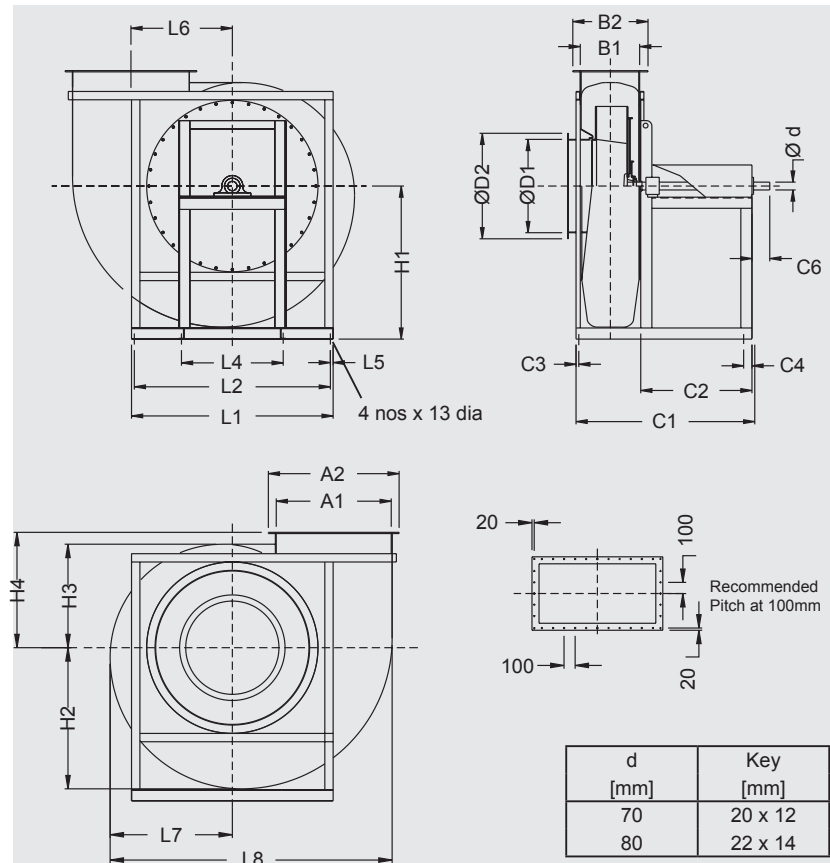

Drehrichtung von Antriebsseite aus gesehen  
 G = Gewicht des nackten Ventilators ohne Antrieb  
 The direction of rotation is as viewed from the drive side  
 G = Barefan weight approximatly

Größe size	A1 [mm]	A2 [mm]	B1 [mm]	B2 [mm]	C1 [mm]	C2 [mm]	C3 [mm]	C4 [mm]	C6 [mm]	D1 [mm]	D2 [mm]	d [mm]	H1a [mm]	H1b [mm]
710	830	940	477	577	1417	761	25	75	160	710	810	70	1130	1000
800	935	1065	538	638	1756	1000	25	75	160	800	900	70	1278	1105
900	1034	1176	615	715	1833	1000	25	75	160	900	1000	70	1375	1200
1000	1160	1302	677	777	1896	1000	25	75	200	1000	1100	80	1550	1350

Größe size	H1c [mm]	H1d [mm]	H1e [mm]	H2 [mm]	H3 [mm]	H4 [mm]	L1 [mm]	L2 [mm]	L4 [mm]	L5 [mm]	L6 [mm]	L7 [mm]	L8 [mm]	G [kg]
710	TBA	1280	1230	1014	744	829	1450	1400	721	25	729	2029	879	430
800	TBA	1428	1362	1141	837	933	1632	1582	818	25	821	2282	989	520
900	TBA	1560	1500	1268	930	1037	1813	1763	914	25	912	2536	1099	650
1000	TBA	1760	1600	1420	1041	1161	2030	1980	1030	25	1021	2840	1231	752

Maß- und Konstruktionsänderungen, dem technischen Fortschritt dienend, bleiben uns vorbehalten.  
 We reserve the right to alter measurements without notice in case of technical improvements

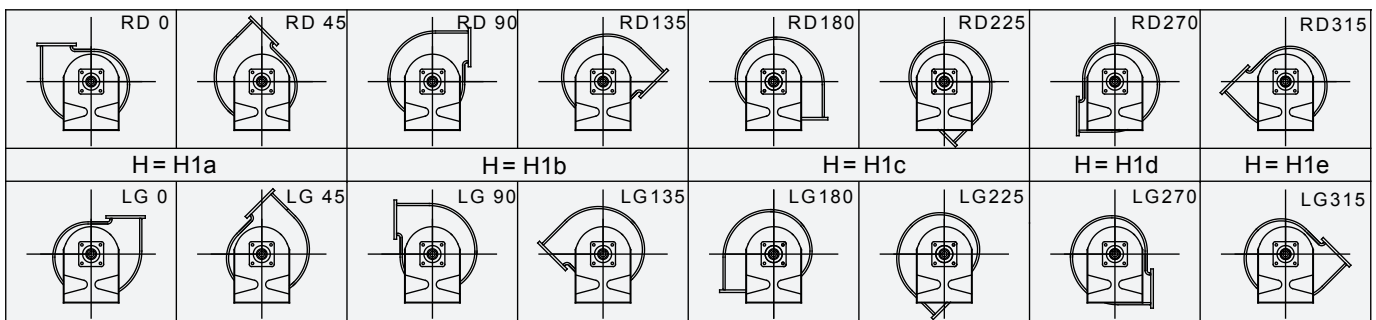

# SPECIFICATION



Description	Specified	Offered						
<b>CHEMCO Chemical Resistant Centrifugal Fan Model CHEM LS 125 ~ 160DD (Direct Driven)</b>	Polypropylene Plastic Fan							
Fan Location								
Volume m <sup>3</sup> /h External static pressure Pa Fan speed min <sup>-1</sup> Brake-Input kW Motor-Output kW Full load Current A A-weighted Sound power level dB(A) Fan Weight Kg Standard Colour - Grey RAL 7032	PANTONE warm Grey 1C							
Type of Casing Precision plastic injection moulded, suitable for dual rotation at any position. Injection moulded back plate & inlet cover can be removed for changing of rotation and maintenance. Outlet flange comes with chemical resistant seal to prevent air leakage. No metal parts are situated in the airflow to eliminate the risk of corrosion. Casings with drain outlets at lowest point. Can be rotated to suit different discharge positions. <sup>c/w</sup> back draft rubber seal between casing and drive shaft.	Polypropylene							
Type of Impeller Impellers are of Single Inlet Single Width (SISW) type. Precision plastic injection moulded with cast-in hub. The hubs are designed for use with taper-bushes to guarantee high reliability at high peripheral speeds	Polypropylene Radial Tip Backward Curve							
Performance tested Fan rated in accordance with: Impeller is statically and dynamically balanced in two planes.	ISO 5801 G2.5 of VDI 2060							
Fan Base and Support Heavy gauge mild steel with maximum protection in the most adverse condition	Hot-dipped galvanised							
Type of Drive	Direct Driven							
Motor Drive Shaft Solid type ground and polished to give tight, accurate bearing fit.	DIN17210-C45 or AISI C-1045							
Motor Bearing Fitted with two standard anti-friction bearings with acid proof seal. L10 life	Grooved balls							
Electric motor Standard Flameproof Tropicalised  Single Phase: Three Phase:	Yes/No Yes/No Yes/No 220~240 volts 50/60 Hz 380~415 volts 50/60 Hz							
Special Accessories Required  Anti-vibration spring mounting Inlet sleeve with clamping bands Splinter protection cover	Yes/No Yes/No Yes/No							
Optional Requirement  Temperature (°C) Casing material Impeller material Fan Base and Support	80 PA / PC / PVC / PVDF PA / PC / PVC / PVDF SS304 / SS316							
Flame Retardant Ultra Violet protection	Yes/No Yes/No							
Electrostatic Discharge  Anti-static Static dissipative Conductive	Yes/No Yes/No Yes/No							
Maximum operating sound power level (dB re10 <sup>-12</sup> W):								
Octave band mid frequency (Hz)	63	125	250	500	1K	2K	4K	8K
Specified								
Offered								

Description		Specified	Offered					
<b>CHEMCO Chemical Resistant Centrifugal Fan Model CHEM LS 125 ~ 160BD (Belt Driven)</b>		Polypropylene Plastic Fan						
Fan Location								
Volume	m <sup>3</sup> /h							
External static pressure	Pa							
Fan speed	min <sup>-1</sup>							
Brake-Input	kW							
Motor-Output	kW							
Full load Current	A							
A-weighted Sound power level	dB(A)							
Fan Weight	Kg							
Standard Colour - Grey RAL 7032		PANTONE warm Grey 1C						
<b>Type of Casing</b> Precision plastic injection moulded, suitable for dual rotation at any position. Injection moulded back plate & inlet cover can be removed for changing of rotation and maintenance. Outlet flange comes with chemical resistant seal to prevent air leakage. No metal parts are situated in the airflow to eliminate the risk of corrosion. Casings with drain outlets at lowest point. Can be rotated to suit different discharge positions. C/W back draft rubber seal between casing and drive shaft.		Polypropylene						
<b>Type of Impeller</b> Impellers are of Single Inlet Single Width (SISW) type. Precision plastic injection moulded with cast-in hub. The hubs are designed for use with taper-bushes to guarantee high reliability at high peripheral speeds		Polypropylene Radial Tip Backward Curve						
<b>Performance tested</b> Fan rated in accordance with: Impeller is statically and dynamically balanced in two planes.		ISO 5801 G2.5 of VDI 2060						
<b>Fan Base and Support</b> Heavy gauge mild steel with maximum protection in the most adverse condition		Hot-dipped galvanised						
<b>Type of Drive</b>		Belt Driven						
<b>Drive Shaft</b> Solid type ground and polished to give tight, accurate bearing fit.		DIN17210-C45 or AISI C-1045						
<b>Bearing</b> Belt driven flange mounted bearing housings type. Fitted with two standard anti-friction bearings with acid proof seal. L10 life		Aluminium cast type Grooved balls						
<b>Fan Drive</b> Fan and Motor Pulley drive come with taper bush type balanced to: Vee belts conform to:		ISO 4183-1980 ISO 4148						
<b>Electric motor</b> Standard Flameproof Tropicalised		Yes/No Yes/No Yes/No Single Phase: Three Phase:	220~240 volts 50/60 Hz 380~415 volts 50/60 Hz					
<b>Special Accessories Required</b> Anti-vibration spring mounting Motor guard Motor slide rails Belt guard Inlet sleeve with clamping bands Splinter protection cover		Yes/No Yes/No Yes/No Yes/No Yes/No Yes/No						
<b>Optional Requirement</b> Temperature (°C) Casing material Impeller material Stainless steel shaft Fan Base and Support		80 PA / PC / PVC / PVDF PA / PC / PVC / PVDF SS304 / SS316 SS304 / SS316						
Flame Retardant Ultra Violet protection		Yes/No Yes/No						
<b>Electrostatic Discharge</b> Anti-static Static dissipative Conductive		Yes/No Yes/No Yes/No						
Maximum operating sound power level (dB re10 <sup>-12</sup> W):								
Octave band mid frequency (Hz)	63	125	250	500	1K	2K	4K	8K
Specified								
Offered								

# SPECIFICATION



Description	Specified	Offered						
<b>CHEMCO Chemical Resistant Centrifugal Fan Model CHEM LS 200 ~ 315DD (Direct Driven)</b>	GRP / PP Plastic Fan							
Fan Location								
Volume m <sup>3</sup> /h External static pressure Pa Fan speed min <sup>-1</sup> Brake-Input kW Motor-Output kW Full load Current A A-weighted Sound power level dB(A) Fan Weight Kg Standard Colour - Volcano Grey	PANTONE 430							
Type of Casing Fibre Glass-Reinforced Plastic (GRP/FRP), Vinyl ester grade. Come with Injection moulded PP back plate can be removed for changing of rotation and maintenance. Straight outlet flange for easy duct connection. Max. Temp. 100°C. No metal parts are situated in the airflow to eliminate the risk of corrosion. Casings with drain outlets at lowest point. Casing can be rotated to suit different discharge positions. C/W back draft rubber seal between casing and drive shaft.	GRP							
Type of Impeller Impellers are of Single Inlet Single Width (SISW) type. Precision plastic injection moulded with cast-in hub. The hubs are designed for use with taper-bushes to guarantee high reliability at high peripheral speeds	Polypropylene Radial Tip Backward Curve							
Performance tested Fan rated in accordance with: Impeller is statically and dynamically balanced in two planes.	ISO 5801 G2.5 of VDI 2060							
Fan Base and Support Heavy gauge mild steel with maximum protection in the most adverse condition	Hot-dipped galvanised							
Type of Drive	Direct Driven							
Motor Drive Shaft Solid type ground and polished to give tight, accurate bearing fit.	DIN17210-C45 or AISI C-1045							
Motor Bearing Fitted with two standard anti-friction bearings with acid proof seal. L10 life	Grooved balls							
Electric motor Standard Flameproof Tropicalised Single Phase: Three Phase:	Yes/No Yes/No Yes/No 220~240 volts 50/60 Hz 380~415 volts 50/60 Hz							
Special Accessories Required Anti-vibration spring mounting Inlet sleeve with clamping bands Splinter protection cover	Yes/No Yes/No Yes/No							
Optional Requirement Temperature (°C) Casing material Impeller material Fan Base and Support	80 PA / PC / PVC / PVDF PA / PC / PVC / PVDF SS304 / SS316							
Flame Retardant Ultra Violet protection	Yes/No Yes/No							
Electrostatic Discharge Anti-static Static dissipative Conductive	Yes/No Yes/No Yes/No							
Maximum operating sound power level (dB re10 <sup>-12</sup> W):								
Octave band mid frequency (Hz)	63	125	250	500	1K	2K	4K	8K
Specified								
Offered								

Description		Specified	Offered					
<b>CHEMCO Chemical Resistant Centrifugal Fan Model CHEM LS 200 ~ 315BD (Belt Driven)</b>		GRP / PP Plastic Fan						
Fan Location								
Volume	m <sup>3</sup> /h							
External static pressure	Pa							
Fan speed	min <sup>-1</sup>							
Brake-Input	kW							
Motor-Output	kW							
Full load Current	A							
A-weighted Sound power level	dB(A)							
Fan Weight	Kg							
Standard Colour - Volcano Grey		PANTONE 430						
<b>Type of Casing</b> Fibre Glass-Reinforced Plastic (GRP/FRP), Vinyl ester grade. Come with Injection moulded PP back plate can be removed for changing of rotation and maintenance. Straight outlet flange for easy duct connection. Max. Temp. 100°C. No metal parts are situated in the airflow to eliminate the risk of corrosion. Casings with drain outlets at lowest point. Casing can be rotated to suit different discharge positions. $C/W$ back draft rubber seal between casing and drive shaft.		GRP						
<b>Type of Impeller</b> Impellers are of Single Inlet Single Width (SISW) type. Precision plastic injection moulded with cast-in hub. The hubs are designed for use with taper-bushes to guarantee high reliability at high peripheral speeds		Polypropylene Radial Tip Backward Curve						
<b>Performance tested</b> Fan rated in accordance with: Impeller is statically and dynamically balanced in two planes.		ISO 5801 G2.5 of VDI 2060						
<b>Fan Base and Support</b> Heavy gauge mild steel with maximum protection in the most adverse condition		Hot-dipped galvanised						
<b>Type of Drive</b>		Belt Driven						
<b>Drive Shaft</b> Solid type ground and polished to give tight, accurate bearing fit. <b>Bearing</b> Belt driven flange mounted bearing housings type. Fitted with two standard anti-friction bearings with acid proof seal. L10 life		DIN17210-C45 or AISI C-1045  Aluminium cast type Grooved balls						
<b>Fan Drive</b> Fan and Motor Pulley drive come with taper bush type balanced to: Vee belts conform to:		ISO 4183-1980 ISO 4148						
<b>Electric motor</b> Standard Flameproof Tropicalised		Yes/No Yes/No Yes/No Single Phase: 220~240 volts 50/60 Hz Three Phase: 380~415 volts 50/60 Hz						
<b>Special Accessories Required</b> Anti-vibration spring mounting Motor guard Motor slide rails Belt guard Inlet sleeve with clamping bands Splinter protection cover		Yes/No Yes/No Yes/No Yes/No Yes/No Yes/No Yes/No						
<b>Optional Requirement</b> Temperature (°C) Casing material Impeller material Stainless steel shaft Fan Base and Support		80 PA / PC / PVC / PVDF PA / PC / PVC / PVDF SS304 / SS316 SS304 / SS316						
Flame Retardant Ultra Violet protection		Yes/No Yes/No						
<b>Electrostatic Discharge</b> Anti-static Static dissipative Conductive		Yes/No Yes/No Yes/No						
Maximum operating sound power level (dB re10 <sup>-12</sup> W):								
Octave band mid frequency (Hz)	63	125	250	500	1K	2K	4K	8K
Specified								
Offered								

# SPECIFICATION



Description	Specified	Offered
<b>CHEMCO Chemical Resistant Centrifugal Fan Model CHEM LS 355 ~ 630DD (Direct Driven)</b>	GRP / PP Plastic Fan	
Fan Location		
Volume m <sup>3</sup> /h External static pressure Pa Fan speed min <sup>-1</sup> Brake-Input kW Motor-Output kW Full load Current A A-weighted Sound power level dB(A) Fan Weight Kg Standard Colour - Volcano Grey	PANTONE 430	
Type of Casing Fibre Glass-Reinforced Plastic (GRP/FRP), Vinyl ester grade. Come with Injection moulded PP back plate can be removed for changing of rotation and maintenance. Straight outlet flange for easy duct connection. Max. Temp. 100°C. No metal parts are situated in the airflow to eliminate the risk of corrosion. Casings with drain outlets at lowest point. Casing can be rotated to suit different discharge positions. C/W back draft rubber seal between casing and drive shaft.	GRP	
Type of Impeller Impellers are of Single Inlet Single Width (SISW) type. Precision plastic injection moulded with cast-in hub. The hubs are designed for use with taper-bushes to guarantee high reliability at high peripheral speeds	Polypropylene Radial Tip Backward Curve	
Performance tested Fan rated in accordance with: Impeller is statically and dynamically balanced in two planes.	ISO 5801 G2.5 of VDI 2060	
Fan Base and Support Heavy gauge mild steel with maximum protection in the most adverse condition	Hot-dipped galvanised	
Type of Drive	Direct Driven	
Motor Drive Shaft Solid type ground and polished to give tight, accurate bearing fit.	DIN17210-C45 or AISI C-1045	
Motor Bearing Fitted with two standard anti-friction bearings with acid proof seal. L10 life	Grooved balls	
Electric motor Standard Flameproof Tropicalised  Three Phase:	Yes/No Yes/No Yes/No 380~415 volts 50/60 Hz	
Special Accessories Required  Inspection Door/Cover Anti-vibration spring mounting Inlet sleeve with clamping bands Splinter protection cover	Yes/No Yes/No Yes/No Yes/No	
Optional Requirement  Temperature (°C) Casing material Impeller material Fan Base and Support	80 PA / PC / PVC / PVDF PA / PC / PVC / PVDF SS304 / SS316	
Flame Retardant Ultra Violet protection	Yes/No Yes/No	
Electrostatic Discharge  Anti-static Static dissipative Conductive	Yes/No Yes/No Yes/No	
Maximum operating sound power level (dB re10 <sup>-12</sup> W):		
Octave band mid frequency (Hz)	63	125
Specified		
Offered		

# SPECIFICATION



Description	Specified	Offered						
<b>CHEMCO Chemical Resistant Centrifugal Fan</b> <b>Model CHEM LS 355 ~ 1000BD (Belt Driven)</b>  Fan Location	GRP / PP Plastic Fan							
Volume m <sup>3</sup> /h External static pressure Pa Fan speed min <sup>-1</sup> Brake-Input kW Motor-Output kW Full load Current A A-weighted Sound power level dB(A) Fan Weight Kg Standard Colour - Volcano Grey	PANTONE 430							
<b>Type of Casing</b> Fibre Glass-Reinforced Plastic (GRP/FRP), Vinyl ester grade. Come with Injection moulded PP back plate can be removed for changing of rotation and maintenance. Straight outlet flange for easy duct connection. Max. Temp. 100°C.  No metal parts are situated in the airflow to eliminate the risk of corrosion. Casings with drain outlets at lowest point. Casing can be rotated to suit different discharge positions. °/w back draft rubber seal between casing and drive shaft.	GRP							
<b>Type of Impeller</b> Impellers are of Single Inlet Single Width (SISW) type. Precision plastic injection moulded with cast-in hub. The hubs are designed for use with taper-bushes to guarantee high reliability at high peripheral speeds	Polypropylene Radial Tip Backward Curve							
<b>Performance tested</b> Fan rated in accordance with: Impeller is statically and dynamically balanced in two planes.	ISO 5801 G2.5 of VDI 2060							
<b>Fan Base and Support</b> Heavy gauge mild steel with maximum protection in the most adverse condition	Hot-dipped galvanised							
<b>Type of Drive</b>	Belt Driven							
<b>Drive Shaft</b> Solid type ground and polished to give tight, accurate bearing fit. <b>Bearing</b> Belt driven flange mounted bearing housings type. Fitted with two standard anti-friction bearings with acid proof seal. L10 life	DIN17210-C45 or AISI C-1045  Aluminium cast type Grooved balls							
<b>Fan Drive</b> Fan and Motor Pulley drive come with taper bush type balanced to: Vee belts conform to:	ISO 4183-1980 ISO 4148							
<b>Electric motor</b> Standard Flameproof Tropicalised  Three Phase:	Yes/No Yes/No Yes/No 380~415 volts 50/60 Hz							
<b>Special Accessories Required</b>  Inspection Door/Cover Anti-vibration spring mounting Motor guard Motor slide rails Belt guard Inlet sleeve with clamping bands Splinter protection cover Manual / Semi / Automatic greasing system	Yes/No Yes/No Yes/No Yes/No Yes/No Yes/No Yes/No Yes/No							
<b>Optional Requirement</b>  Temperature (°C) Casing material Impeller material Stainless steel shaft Fan Base and Support	80 PA / PC / PVC / PVDF PA / PC / PVC / PVDF SS304 / SS316 SS304 / SS316							
Flame Retardant Ultra Violet protection	Yes/No Yes/No							
<b>Electrostatic Discharge</b>  Anti-static Static dissipative Conductive	Yes/No Yes/No Yes/No							
Maximum operating sound power level (dB re10 <sup>-12</sup> W):								
Octave band mid frequency (Hz)	63	125	250	500	1K	2K	4K	8K
Specified								
Offered								

# Sales Network

## Deutschland

Wolter GmbH.  
Maschinen-und Apparatebau KG.  
DE-76316 Malsch  
T +49 (0) 72 04 / 92 01 0  
F +49 (0) 72 04 / 92 01 11  
info@wolter.eu

## Europe

### Denmark:

L.ØLAND VENTILATION A/S  
DK-2605 Brøndby  
T +45 (0) 70 / 20 19 11  
salg@airforce.dk

### Netherlands:

DE WIT Ventilatoren BV  
NL-3821 CG Amersfoort  
T +31 (0) 33 / 76 00 240  
info@dewitventilatoren.nl

### Sweden:

Nordisk Ventilator AB  
SE-142 50 Skogås  
T +46 (0) 8 / 72 70 250  
se@nordiskventilator.se

### Switzerland:

Anson AG Zürich  
CH-8055 Zürich  
T +41 (0) 44 / 46 11 111  
F +41 (0) 44 / 46 13 111  
info@anson.ch

### OZ Tech SA

CH-1122 Romanel-sur-Morges  
T +41 (0) 76 / 41 11 572  
info@oztech.ch

### United Kingdom:

Wolter (UK) Ltd.  
GB-Leicestershire LE65 1AL  
T +44 (0) 15 30 / 41 24 73  
info@wolteruk.com

## Middle East

### UAE, Saudi Arabia, Qatar, Lebanon:

Please contact Wolter head office

### Wolter GmbH.

Maschinen-und Apparatebau KG.  
DE-76316 Malsch  
T +49 (0) 72 04 / 92 01 0  
F +49 (0) 72 04 / 92 01 11  
info@wolter.eu

## Asia

### China:

Guangdong Wolter Chemco Ventilation Ltd.  
Boluo, Huizhou, Guangdong

Dongguan Wolter Chemco Ventilation Ltd.

Shipai, Dongguan, Guangdong  
T +86 (0) 769 / 8655 7298  
F +86 (0) 769 / 8655 7278  
info@wolter.com.hk

Taizhou Wolter Ventilation Co. Ltd.

Hengjie, Luqiao District,  
Taizhou, Zhejiang  
T +86 (0) 576 / 26 22 666 (26 52 888)  
F +86 (0) 576 / 26 56 830

### China - Hong Kong, Macau:

Wolter Asia Ltd  
Kowloon, Hong Kong  
T +852 (0) 2456 0198  
F +852 (0) 2456 0290  
info@wolter.com.hk

### China - Taiwan:

Waxlink International Co., Ltd.  
8F-2 No.218 Roosevelt Rd.,  
Sec.6, Taipei, Taiwan  
T +886 (0) 2 / 8932 1196  
F +886 (0) 2 / 8932 1197  
waxlink@mail.waxlinktw.com

## India:

Wolter Ventilators India Pvt. Ltd.  
867 D, Block-A, Sushant Lok, Phase-I,  
Gurgaon - 122009 (Haryana)  
T +91 (0) 124 2577797, 4261001-3  
sales@wolterindia.in

## Korea:

Kaceco-Wolter  
14-1, Dang-dong, Gunpo-shi,  
Gyeonggi-do  
T +(82) 0 31 / 4773 104  
F +(82) 0 31 / 4773 132  
wolter@kaceco.com  
info@kaceco.com

## Malaysia:

Vibrantech (M) Sdn Bhd.  
47200 Petaling Jaya Selangor  
T +603 (0) 7847 3500  
F +603 (0) 7847 3380  
sales@vibrantech-sb.com

## Singapore:

Wolter Pte. Ltd.  
SG-569738 Singapore  
T +65 (0) 63 / 52 95 48  
F +65 (0) 63 / 52 95 47  
info@wolterfans.com.sg

## Thailand:

Wolter Ventilation Co., Ltd.  
Thamai Kratumban Samutsakorn  
741 10 Thailand  
T +66 (0) 84 555 2936  
kongsakol@wolterfan.com

## Australia

The Sydney Fan Company.  
NSW 2147, Sydney, Australia  
T +61 (0) 2 / 9624 4000  
F +61 (0) 2 / 9624 4100  
sales@thesydneyfancompany.com

## Wolter GmbH Maschinen-und Apparatebau KG

Am Wasen 11  
DE-76316 Malsch / Germany  
T +49 (0) 72 04 / 92 01 0  
F +49 (0) 72 04 / 92 01 11  
www.wolter.eu  
info@wolter.eu

