



OPERATION AND MAINTENANCE MANUAL

- In-Line Tube Fans with EC Motor

With Plastic Casing - Type RK

With Steel Casing - Type RS



M-Tube.EC V2023/Dec

TABLE OF CONTENTS



1	General Notes.....	3
1.1	Exclusion of Liability.....	3
1.2	Technical Data.....	3
1.3	Nameplate.....	4
1.4	Product Dimensions.....	4
2	Safety.....	6
2.1	Symbol.....	6
2.2	Basic Safety Rules.....	7
3	Storage and Transport Guidelines.....	8
4	Assembly and Installation.....	9
4.1	Installation Recommendations.....	9
4.2	Mains Supply Guidelines.....	10
4.2.1	Mains Fuse Protection.....	11
4.2.2	Usage of Motor Protection Switches.....	11
4.2.3	Additional Protection with a Residual Current Protective Device (RCD).....	12
4.3	Control Signal.....	12
4.4	Fault Relay.....	12
4.5	High Potential Test / Insulation Resistance Test.....	12
4.5.1	High Voltage Test.....	12
4.5.2	Insulation Resistance Test.....	12
5	Wiring Diagram.....	13
6	Commissioning.....	14
6.1	Configuration to External Device.....	15
6.2	Speed Adjustment Characteristics.....	15
6.2.1	Determination of the Speed Setpoint Input U (setpoint) for a Given Target Speed n (setpoint).....	15
6.2.2	Determination of the Nominal Speed n (target) for a Given Speed Setpoint U (setpoint).....	15
6.3	Alarm Relay Characteristics.....	15
7	Protective Features.....	16
8	Maintenance, Repair.....	16
9	Disposal.....	17
9.1	Disassembly.....	17
9.2	Disposal of Components.....	17
10	Failure.....	18
11	Troubleshooting.....	19
12	CE Marking.....	21
12.1	Declaration of Conformity.....	21
12.2	Declaration of Incorporation.....	21

Introduction

This publication is for use on standard duct fan and all information are subjected to changes or amendment with or without notification.

It is the users responsibility to ensure this documents are most updated and it is only serve as a guideline for installation, use, maintenance and repair work.

Always consult the manufacturer, if necessary and thus the manufacturer cannot be held responsible for any damage resulting of this publication or either for any errors occurring in this publication. All rights reserved.

1 General Notes

Duct fans were especially developed for use in modern ventilation systems. By using external rotor motors there are significant technical advantages in operation. All duct fans are 100% speed controllable and are statically and dynamically balanced as a composite unit in our factory. The fans are also available with motor/impellers to be folded out for maintenance.

Prior to installing and using this fan, please ensure that you thoroughly read this operating manual. Note that this manual pertains specifically to certain units and does not apply to the entire system. It includes crucial safety guidelines and operational information necessary for trouble-free use. This document should be considered an integral part of the device and must be provided if the device is sold or transferred.

1.1 Exclusion of Liability

Wolter assumes no responsibility for any damage resulting from misuse, improper use, unauthorized modifications, repairs, or any issues arising from the design of the end product / system.

1.2 Technical Data

The fan technical data are shown as per below:

Nr	Model	Poles (-)	Phases (-)	Voltage (VAC)	Frequency (Hz)	Input Power (W)	Current (A)	Speed (r/min)	Perm.Amb.T (°C)	IP (-)	I.C (-)	Weight (kg)
1	RK-EC 100L	2	1	230	50/60	120	0.95	3500	-25~50	IP54	F	2.0
2	RK-EC 125L	2	1	230	50/60	120	0.95	3500	-25~50	IP54	F	2.1
3	RK-EC 150M	2	1	230	50/60	120	0.95	3500	-25~50	IP54	F	3.2
4	RK-EC 150L	2	1	230	50/60	115	1.00	2750	-25~50	IP54	F	3.8
5	RK-EC 160M	2	1	230	50/60	120	0.95	3500	-25~50	IP54	F	3.3
6	RK-EC 160L	2	1	230	50/60	115	1.00	2750	-25~50	IP54	F	3.8
7	RK-EC 200M	2	1	230	50/60	115	1.00	2750	-25~50	IP54	F	3.8
8	RK-EC 200L	2	1	230	50/60	150	1.10	2750	-25~50	IP54	F	4.4
9	RK-EC 250M	2	1	230	50/60	115	1.00	2750	-25~50	IP54	F	3.8
10	RK-EC 250L	2	1	230	50/60	150	1.10	2750	-25~50	IP54	F	4.4
11	RK-EC 315M	2	1	230	50/60	265	1.90	2800	-25~50	IP54	F	5.4
12	RK-EC 315L	2	1	230	50/60	245	1.70	2600	-25~50	IP54	F	6.8

GENERAL NOTES



Nr	Model	Poles (-)	Phases (-)	Voltage (VAC)	Frequency (Hz)	Input Power (W)	Current (A)	Speed (r/min)	Perm. Amb. T (°C)	IP (-)	IC (-)	Weight (kg)
1	RS-EC 100	2	1	230	50/60	100	0.85	3500	-25~50	IP54	F	3.5
2	RS-EC 125	2	1	230	50/60	115	1.20	3500	-25~50	IP54	F	3.5
3	RS-EC 160	2	1	230	50/60	125	1.10	2750	-25~50	IP54	F	5.0
4	RS-EC 200	2	1	230	50/60	120	1.20	2750	-25~50	IP54	F	5.2
5	RS-EC 250	2	1	230	50/60	190	1.65	2800	-25~50	IP54	F	5.5
6	RS-EC 315	2	1	230	50/60	230	2.10	2600	-25~50	IP54	F	6.5
7	RS-EC 355	4	1	230	50/60	320	1.40	1800	-25~50	IP54	F	14.2

1.3 Nameplate

Exemplary description of the fan nameplate.

Wolter Asia Ltd. info@wolter.com.hk T +852 - 2456 0198		
Ref. No. : XXX-XX-02 Job No. : 23-JNxxx Art. No. : INS2023060800XX P (kW) : 0.125 n (min-1) : 2750 tR (°C) : 50	Model : RS-EC 160 I (A) : 1.1 V,ph,HZ : 230,1,50/60 Ins. CL : F μF, 400V : - Wt. (kg) : 5.0	
Quality Assurance and certified : ISO 9001:2015 Conformity with ISO 5801, AMCA 210 & GB/T 1236 Wolter GmbH Maschinen - und Apparatebau KG Guangdong Wolter Chemco Ventilation Ltd Dongguan Wolter Chemco Ventilation Ltd www.wolter.com.hk		

1.4 Product Dimensions

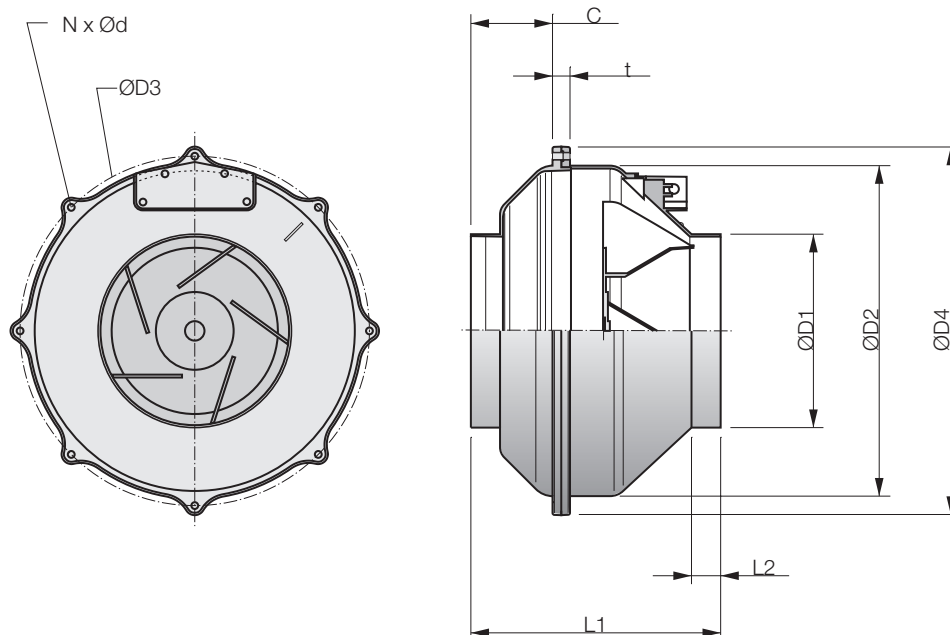

GENERAL NOTES



RK-EC

Model Size	C [mm]	d [mm]	D1 [mm]	D2 [mm]	D3 [mm]	D4 [mm]	L1 [mm]	L2 [mm]	N [mm]	t [mm]
RK-EC 100L	101	7	99	251	270	288	247	30	6	18
RK-EC 125L	101	7	124	251	270	288	247	30	6	18
RK-EC 150M	84	7	149	340	360	379	230	30	8	18
RK-EC 150L	84	7	149	340	360	379	230	30	8	18
RK-EC 160M	84	7	159	340	360	379	230	30	8	18
RK-EC 160L	84	7	159	340	360	379	230	30	8	18
RK-EC 200M	84	7	199	340	360	379	230	30	8	18
RK-EC 200L	84	7	199	340	360	379	258	30	8	18
RK-EC 250M	84	7	249	340	360	379	230	30	8	18
RK-EC 250L	84	7	249	340	360	379	255	30	8	18
RK-EC 315M	106	7	314	404	426	452	275	30	8	18
RK-EC 315L	106	7	314	404	426	452	275	30	8	18

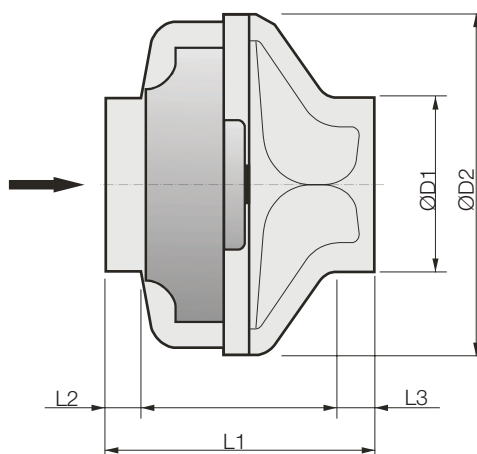

RS-EC















Model Size	D1 [mm]	D2 [mm]	L1 [mm]	L2 [mm]	L3 [mm]
RS-EC 100	97	242	195	23	23
RS-EC 125	125	242	190	23	23
RS-EC 160	160	332	230	25	25
RS-EC 200	200	332	225	25	25
RS-EC 250	248	332	235	25	25
RS-EC 315	315	402	270	28	28
RS-EC 355	355	500	400	32	32

Note: We reserve the right to alter drawings / measurements without notice in case of technical improvements.

2 Safety

Observe the following safety warnings to prevent personal injury or equipment faults.

2.1 Symbols

	Attention Danger Safety advice	Indicates an immediate hazard that could lead to serious injury or death if not avoided. Compliance is mandatory.
	Warning	Procedures which, if not carried out with the necessary caution, may damage the product or cause serious personal injury.
	Warning	Fire hazard! Important warning to prevent fire.
	Attention	Identifies information about practices or circumstances that can cause an explosion in a hazardous environment, which may lead to personal injury, death, property damage, or economic loss.
	Attention	A remark with additional information for the user. A remark brings possible problems to the user's attention.
	Caution	Procedures, if not carried out with the necessary caution, could damage the product, the workshop or the environment.
	Mortal danger	Electrical hazard. Serious - and also fatal - injury can result if these notes are disregarded.
	Shock hazard	Labels may be on outside or inside of fans and control boxes used in the exhaust removal system, to alert people that dangerous voltage may be present.
	ARC flash hazard	Labels may be on outside or inside of the equipment, for example control box, to alert people to potential Arc Flash. Arc Flash will cause severe injury or death. Wear proper Personal Protection Equipment (PPE). Follow ALL regulatory requirements for safe work practices and for Personal Protective Equipment (PPE)
	Crush danger	
	Danger	Do not step under hanging load!
	Danger	Hot surface!
	Attention	Use hand protection.
	Attention	Use a helmet
	Attention	Use a hearing protection

SAFETY



Tip Suggestions and recommendations to simplify carrying out tasks and actions.



Note Indicates user tips and other useful advice.

2.2 Basic Safety Rules



Do not make any additions or modifications to the equipment without Wolter's approval. Using parts not approved by Wolter places responsibility for any resulting hazards on the user.



Requirements for Personnel

Only trained and qualified personnel should undertake installation, electrical connections, maintenance, servicing, and disassembly, in accordance with relevant regulations and directives.



Before Working on the Device

- Switch off power.
- Ensure all parts and components are securely locked and enclosed.
- Verify grounding and short-circuiting of lines and equipment.
- Cover partitions or screens between adjacent sections.



Risk of injury

- Wait until the impeller stops.
- Before and after working on the unit, remove any tools or other objects from the unit.
Danger from flying parts!



Attention! During operation, the motor housing can reach high temperatures.



Rotating Impeller

- Long hair, loose items of clothing, or jewelry could become entangled in the device, causing injury.
- Do not wear any loose clothing or jewelry while working on rotating parts.
- Protect long hair by wearing a cap.



Only use the fan after it has been securely mounted and fitted with protection guards suited to the application. The protection guards must be certified to EN ISO 13857.



Protective Equipment

Ensure appropriate protective equipment is worn. A helmet is recommended when working overhead.



Wolter duct fans are produced in accordance with the latest technical standards and our quality assurance programme, which includes material and function tests, ensures that the final product is of a high quality and durability. The fan must only be used according to its design parameters, with regard to required performance stated in the name-plate and mediums passing through it! Any other use beyond this, if not contractually agreed, is deemed improper. Intended use also includes compliance with the procedures described in these operating instructions during assembly, installation, commissioning, and maintenance. The switching frequency of the fans is designed for continuous operation S1. Connected switchgear should not permit extreme switching operations. Reliable starting of fans is not guaranteed if driven in reverse. If the application requires reliable starting, the system operator or manufacturer must take suitable measures to prevent a counter-rotating drive.



Reliable starting of fans is not guaranteed if driven in reverse. If the application requires reliable starting, the system operator or manufacturer must take suitable measures to prevent a counter-rotating drive.



The unit can be installed in any position as long as ambient conditions do not lead to condensation. If condensation occurs, the unit should only be installed in the horizontal shaft or bottom rotor position to ensure that condensation can escape in a controlled manner.



According to regulation 1253/2014/EU, the fans within the scope of application must be operated in at least a 3-Stage system plus OFF mode.

The operator is responsible for compliant, multi-stage operation. Appropriate switching devices are available.

Intended Use:

- Operation in environments with clean air.
- Compliance with the specified performance limits as indicated on the type plate.
- Operation in air with low dust and grease content. It is essential for the system planner to verify correct operation and, if needed, employ a prefilter.
- For fans with the motor located outside the airflow, the transport of air containing dust and grease is permissible.
- Conveying mildly aggressive gases and vapors.
- Handling mediums with an atmospheric density up to 1.2 kg/m³.
- Handling mediums with humidity levels up to a maximum of 95%, provided there is no condensation.
- Airflow temperature in continuous operation, cooled by convection, ranges from -25°C to the temperature noted on the data plate.
- Maximum installation altitude is 2000m above sea level.



Improper Use:

The following uses of the device are prohibited and can pose hazards. This list is not exhaustive. For any uncertainties, please contact Wolter Asia Ltd directly.

- Operation in explosive atmospheres.
- Conveyance of abrasive or adhesive media, unless special exceptions are arranged.
- Operation under resonance conditions or with significant vibrations, including those transmitted from the customer's system to the fan.
- Operation in unauthorized performance ranges as specified in the product documentation.
- Operation in the presence of imbalance, such as that caused by dirt accumulation or icing.
- Painting or otherwise altering the device.
- Operation with protective devices fully or partially dismantled or modified.
- Conveyance of solids in the medium or heavily dusty air.
- Use as a safety component or for safety-critical functions as specified in ISO 13849-1.
- Operation near flammable substances or components.
- These fans are not suitable for use in kitchen exhaust systems, as per the exclusion outlined in VDI 2052.

3 Storage and Transport Guidelines

Storage and Handling Conditions:

- Ensure the device is safeguarded from environmental influences and contamination until its final installation.
- It is imperative to prevent high humidity and the formation of condensate.
- Environmental parameters: maintain a dry environment with temperatures ranging from -30°C to +80°C.

Transporting the Device:

- Use appropriate load-handling equipment (e.g., lift trucks, cranes) to lift the device. Secure the device adequately (e.g., with straps) to prevent movement during transport, considering the weight specified on the data plate.
- Wear suitable protective gear, including safety shoes and gloves, while handling the device

Storage Requirements:

- Store the device, whether partially assembled or fully packaged, in its original packaging in a clean, dry, vibration-free, and weather-protected location.
- For extended storage durations, periodically rotate the ball bearings (refer to Maintenance and Service instructions).



Caution! Never position yourself beneath a suspended load!

4 Assembly and Installation



Upon unpacking the fan, it is imperative to inspect it for any transport damage. Do not proceed with the installation of damaged fans.

Ensure that no objects or foreign matter fall into the inlet and outlet openings of the fan. Protection guards must comply with EN ISO 13857 standards.



Risk of Cutting and Crushing

- Carefully remove the unit from its packaging by handling the motor flange, motor support plate, or frame. Utilize suitable holding devices if needed.
- Safety shoes and protective gloves are mandatory.

Assembly Instructions

- Ensure adequate space around the intake and outlet areas to maintain efficiency (refer to installation recommendations).
- Employ appropriate assembly aids, such as specification-compliant scaffolds.
- Secure the device at the installation site and ensure all fastening screws are fully tightened.
- Do not install the fan under tension.
- Utilize only approved elastic collars for outlet or inlet connections (available as accessories). Ensure pipes connected to the inlet or outlet are independently supported.
- Avoid the application of force, such as levering or bending.
- Securely fasten the unit at all designated fastening points using appropriate mounting hardware.
- Prevent drill cuttings, screws, and other foreign objects from entering the device.
- For outdoor installations, ensure that weather protection accessories are utilized.



Risk of Electric Shock: Installation Guidelines

- Connect the device only to circuits that can be de-energized using an all-pole disconnecting switch, according to EN 60204-1.
- Ensure electrical connections comply with the technical connection conditions and relevant regulations detailed in the included circuit diagram.
- Properly insert and seal the cable within the terminal box.
- Avoid using cable glands with plastic terminal boxes.
- Accurately connect the equipotential bonding system.
- Position cables so they do not come into contact with any rotating parts.
- Utilize cables that adhere to the specified requirements for voltage, current, insulation material, load, etc.
- Properly insert and seal the cable within the electronic housing, and securely tighten the cable gland with appropriate tools.
- Prevent water ingress through the cable gland; ensure cable glands are always oriented downwards.
- Refer to product dimensions available in the product information.



During fan installation, ensure adequate space is allocated for service and maintenance. For fans equipped with an integrated terminal box, it must remain accessible post-installation. If access is restricted for technical reasons, ensure all control lines are routed to an accessible junction box.



The user is responsible for ensuring the installation and safety information comply with the applicable standards and guidelines.

4.1 Installation Recommendations

Installation and electric work only by skilled and introduced workers and in accordance to applying regulations!

Installation of fan either with mounting flange directly to the duct system, possibly by conjunctions with a sound attenuator or, in order to avoid noise transmission, with flexible connectors, installed on the inlet and outlet.

The standard method of mounting is via a pre-prepared platform or for vertical mounting channel section brackets fixed to the fan casing.

For installation on mounting flange use screws and secure properly.



Avoid sound bridges by use of isolation material (i.e. sponge rubber)

Check impeller rotation by hand for soft running. For external mounting weather protection should be used. This should be designed to suit the installation and is supplied by others.



The duct system must not be supported by the fan casing!

Electric wiring must be in accordance with technical connection regulations and local ordinances and national electric codes as per enclosed wiring diagram in the terminal box or on the casing.

- If the junction box is to be fitted to the fan casing, the holes for fixing must be drilled outside the impeller rotation area.
- Fix the junction box with screws (max. dia of 4 mm) to fan casing.
- Insert cable according to the instructions in the junction box and seal it.
- Connect thermal contacts for motor protection according to the instructions otherwise the guarantee is invalid. Connect electric supply.



Do not use metal compression-gland fittings with plastic terminal boxes!

Before control of direction of rotation:

- Remove any foreign matter from the fan.
- Install protection guards or give no entry to fan.
- Check direction of rotation as per direction arrow on the casing by short turning on.



Crush danger! Do not reach into rotating impeller!

- Close maintenance cover (if any).

4.2 Mains Supply Guidelines



Connecting EC motors directly to the mains is strictly prohibited. Operating the motor requires an external EC controller.

For fans equipped with external power electronics, both the mains connection and control leads should be connected in the terminal box of the electronic unit.



It is mandatory to ground the system using the ground wire connection (Ⓧ) to the potential ground. The ground wire must be of at least the same cross-section as the power supply wire.

The protective conductor strand should be approximately 20 mm longer than the power supply connection strands (L / N) within the area of the mains supply.



The mains connection cables must be suitable for the operational temperature range of the fan. For applications with ambient temperatures up to 60°C, use connection cables approved for at least 80°C.

- The fans must be operated within a neutral point earthed network (Transformer in Y connection) and supplied by a symmetrical sinusoidal earthing system (TNS, TN-C, TN-C-S, TN), with permissible asymmetry less than 2%.
- The fan is also approved for use in IT networks, with the permissible supply voltage asymmetry being less than 2%.
- Additionally, fans can only be operated on mains supplies where the Total Harmonic Distortion (THD) is less than 10%. This THD value applies both between the main phases (L-N) and between the phases to PE (L-PE).
- All mains supply setups must comply with technical connection regulations, local ordinances, and national electric codes.
- Systematically connect the equipotential bonding system to all conductive components.
- Ensure input voltage tolerances are complied with as specified in the Pin connection chapter. Excessive stress may cause motor failure.
- Adhere to the nameplate details (voltage, frequency, temperature range, connection cable, wiring diagram).
- Securely insert and seal the cable in the electronics housing. Use a tool to tighten the cable gland.
- Prevent water ingress through the cable gland by always positioning it downward.
- Cable Installation in Vertical Built-In Fans:
 - The clamping range of the M20 cable gland is 6-12 mm. Choose a cable that fits within this range.
 - While assembling the cover for the cable connection, ensure no small parts, such as stripping material or assembly residues, are trapped between the cover and housing. Tighten screws to 2 Nm.



If leakage current exceeds 3.5 mA, as per EN 61800-5-1, a second earth protection cable of the same dimension as the original must be connected.

Harmonic Distortion:

As per EN 61000-3-2, no harmonic limit values apply to professionally used three-phase fans (Class A) with a rated power exceeding 1 kW.

When individual self-contained devices are installed in a rack or enclosure, they are considered individually connected to the main. The entire frame or housing does not require testing.

If three-phase nominal currents exceed 16A, contact the appropriate energy supply company for technical mains conditions. Additionally, adhere to short circuit power requirements as per EC 61000-3-12 to ensure compliance with limit values.

Recommendations from the standard IEC 61000-3-12:

The three-phase EC motor variants adhere to IEC 61000-3-12 on the condition that the short-circuit power (S_{sc}) at the interface point between the user's supply and the public system is equal to or greater than the specified value. It is incumbent upon the installer or user to ensure, potentially by consulting with the relevant energy supply company, that the equipment is connected only to a suitable supply with a short-circuit power (S_{sc}) that meets or exceeds the specified value. The three-phase EC motors comply with the requirements of IEC 61000-3-12 Table 5, which applies to both asynchronous motors and permanent magnet (PM) motors with sinusoidal back-EMF.

Supply Short-Circuit Power:

Ensure that the supply's short-circuit power (S_{sc}) is computed as follows:

$$S_{sc} = \sqrt{3} \times R_{scc} \times U_{mains} \times I_{equipment}$$

at the interface point between the user's supply and the public system (R_{scc})

The mains voltage must conform to the quality characteristics specified in EN 50160 and the standard voltages defined by IEC 60038.

4.2.1 Mains Fuse Protection



The connection to the low-voltage system shall be performed in accordance with EN 60204-1.

Installation must adhere to the applicable specifications for wire types and cross-sectional areas as per the local National Electrical Code (NEC).

The table assignments of cable cross-sections and associated fuses are intended solely for cable protection and do not substitute device protection.

Fuse		Automatic fuse	Cable cross-section	
VDE	UL	VDE	mm ²	AWG
10A	J10A	C10A	1.5	16
16A	J16A	C16A	1.5	16
20A	J20A	C20A	2.5	14
25A	J25A	C25A	4.0	12

Additional Information per UL Standards:

The equipment is suitable for use on a circuit capable of delivering no more than 5000 RMS symmetrical amperes at a maximum of 480 volts.

The integral solid-state short-circuit protection provided does not equate to branch circuit protection. Thus, branch circuit protection must be provided in accordance with the NEC and any applicable local codes.

4.2.2 Usage of Motor Protection Switches



The use of motor protection switches in the mains supply circuit of the EC fan is prohibited. For guidance on mains line protection, refer to the section "Mains Fuse Protection" for appropriate fuse selection.

4.2.3 Additional Protection with a Residual Current Protective Device (RCD)

If the motor is part of an electrical installation where an RCD is implemented for supplementary protection, the circuit breaker must be of a type that:

- Can handle leakage currents and activate with short-duration, pulse-shaped leakage.
- Trips in response to alternating fault currents and fault currents with DC content, including both pulsating DC and smooth DC fault currents.



For these types of motors, an earth leakage circuit breaker of type B must be used.

When choosing an RCD, the cumulative leakage current from all electrical equipment within the installation must be considered.

4.3 Control Signal

Cable Dimensioning:

Screw Connection M20, Cable Diameter 6-12 mm, Wire Diameter 0.5 mm² - 1.5 mm²

It is crucial to maintain a sufficient distance between the main cable and the control cable (greater than 10 cm).

The control cable must not exceed a length of 30 meters. For lengths over 20 meters, shielded cables must be used. For EMC compliance, ensure the installation is connected at one end to the signal source (e.g., the protective conductor of the fan).

4.4 Fault Relay



The fault relay is designed for a maximum voltage of 250VAC/3A with a maximum current of 3A.

Therefore, the all-pole mains isolating device according to EN 60204-1 for the connection cable of the fault relay can be omitted.

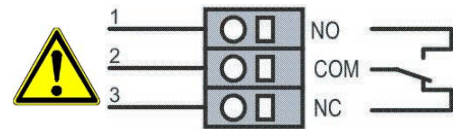

4.5 High Potential Test / Insulation Resistance Test

4.5.1 High Voltage Test



A high-voltage test was conducted at the factory as part of our comprehensive series of tests. In compliance with EN60204-1, it is permissible to disconnect the mains connection and control cable from the EC controller to avoid product damage during subsequent testing.

4.5.2 Insulation Resistance Test



Only Between Mains Connection and Protective Conductor

Testing of the control terminals is prohibited.

- The insulation resistance test must be performed in accordance with EN 60204-1, utilizing a test device compliant with EN 61180, administering 500 VDC between the bridged mains terminals and the protective earth conductor.
- For higher test voltages, it is necessary to disconnect the mains connection and control cable from the EC controller to prevent damage.



Please adhere to the guidelines specified in the "Maintenance, Repair" section when working on the fan.

5 Wiring Diagram

Standard

Single Phase EC Motor Series
(1P, 200~277V, 50/60Hz)

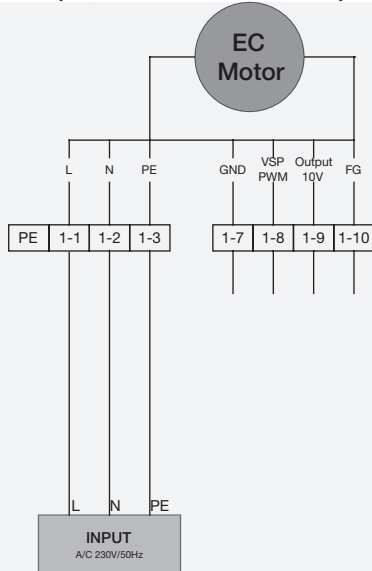

- 1 = Black
- 2 = Blue
- 3 = Yellow-green
- 4 = Red
- 5 = Grey
- 6 = Orange
- 7 = Blue
- 8 = Yellow
- 9 = Red
- 10 = White
- 11 = Green
- 12 = Black
- 13 = Brown

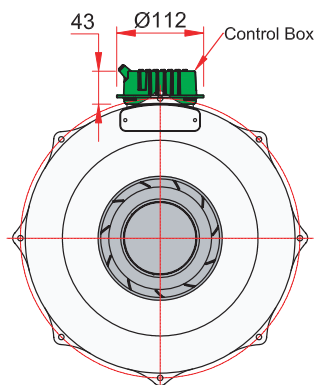

Optional

Single Phase EC Motor Series
(1P, 200~277V, 50/60Hz)

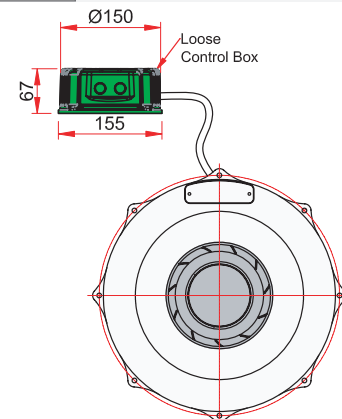
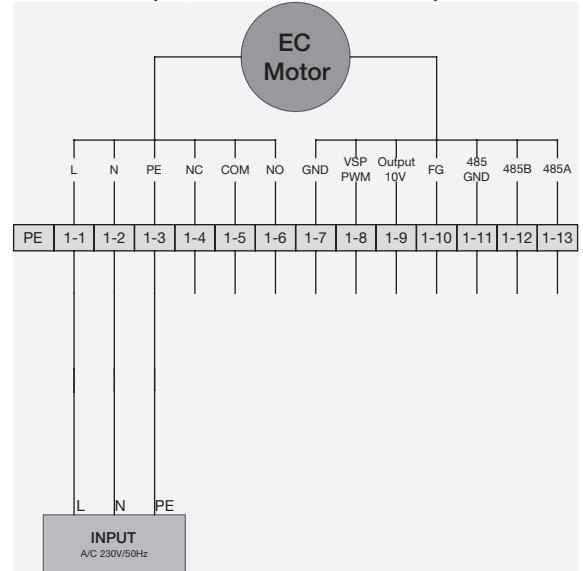

- › L, N : Single-phase supply connection, voltage range 200-277VAC, frequency 50/60Hz
- › PE : Protective earth
- › 485A : RS485 interface for MODBUS-RTU
- › 485B : RS485 interface for MODBUS-RTU
- › 485GND : Reference ground for control interface
- › NC : Status relay, mode2--close on normal, open on fault
- › COM : Common connection of status relay, contact rating 250VAC/3A
- › NO : Status relay, mode2--open on normal, close on fault
- › FG : Speed feedback output, 2 pulses per revolution, can be customized
- › +10V : 10VDC output, maximum output current 10mA
- › VSP/PWM : Speed control signal input connection, 0-10V voltage or PWM signal (amplitude 10-12V, 1-10kHz)
- › GND : Signal ground for control interface



Incorrect wiring may result in the destruction of the electronics!

6 Commissioning



Commissioning is permitted only after verifying all safety protocols and ensuring no hazards are present.



For fans with fold-out sections (such as duct fans or folding roof fans), commissioning is allowed only when the fan section is securely closed.



Emission

Installation and operational factors may result in a sound pressure level exceeding 70 dB(A) (refer to product catalog for precise information).

Risk of noise-induced hearing loss exists;

Appropriate protective measures, such as ear protection, should be taken.

Prior to initial commissioning, ensure the following:

- Installation and electrical work are properly completed.
- Safety devices, including protective guards, are in place.
- The clearance of rotating parts should be verified. Center the inlet cone if necessary.
- The fan should not contact any fixed housing components. Manually rotate the impeller to ensure smooth movement.
- Remove any installation debris and foreign objects from the fan area.
- Ensure the continuous protective conductor is connected.
- Verify cable entry and housing seals.
- Confirm connection data matches the information on the type plate.
- Only commence operation when it is installed in accordance with ordinances!
- If the fan is started under free blow conditions, i.e. prior to connecting to ducting system, the current consumption may exceed the normal maximum (forbidden area of performance curve)!
- The terminal protection of the motor may activate!

Commissioning should proceed according to the instructions in the "Configuration to external device" section by gradually increasing the set point value to verify cyclic operation and speed settings.

- The fan must operate freely and smoothly at all speeds.
- Observe correct function (smoothness of running, vibration, unbalance current consumption, possibly controllability)



By regular inspection of the fan inlet make sure debris has not collected on the guard and clean if necessary!



Note: The electronic housing may become hot after commissioning.

Fan startup involves slight forward and backward motions. Upon reaching minimum speed, continuous commutation (Field Oriented Control - FOC) is activated.

To access the electronics, loosen the cover screws and carefully remove the cover. When stripping connection wires, ensure no conductive strand residues enter the connection area of the mains and control terminals; strands must be assembled outside this area.

- The connection terminals are designed, allowing stripped wires to be easily inserted by simply pushing them into place, whether you're using tools or not.
- Solid and multi-core cables are compatible.
- Ensure correct stripping length or ferrule insertion as follows
 - Mains terminal: 15mm
 - Control terminal: 10mm
- You can remove wires with a light press using a screwdriver or similar tool.

6.1 Configuration to External Device

To activate the fan, a minimal configuration is necessary. For dual assignment of a control signal terminal, the following are permissible:

- 2 strands (rigid or flexible) in a ferrule
- 2 strands (flexible) twisted

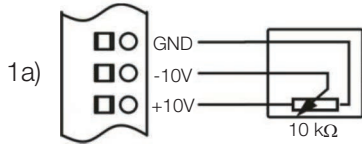

10 kΩ Potentiometer connected to terminals “+10V”, “0-10V,” and “GND” for stepless speed adjustment.

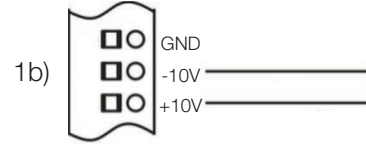

Wire jumper between terminals “+10V” and “0-10V” for maximum fan speed.

6.2 Speed Adjustment Characteristics

The desired revolution rate can be continually adjusted using the connected potentiometer. Voltage signals below 1V are interpreted by the electronics as a stop signal. With a setpoint of 9.5V, the fan operates at maximum speed.

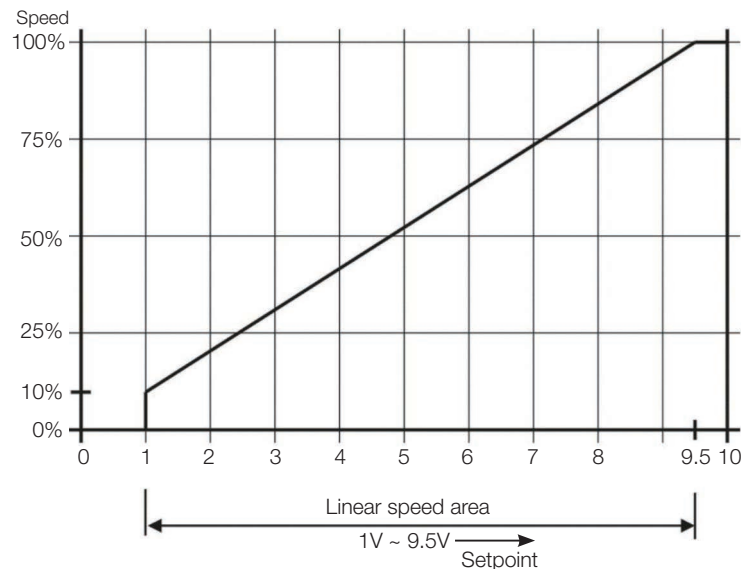

6.2.1 Determination of the Speed Setpoint Input U (setpoint) for a Given Target Speed n (setpoint)

The speed setpoint can be determined using the following calculation:

$$U(T) = \frac{n(T)}{n(R)} \times 9.5$$

U(T) = Setpoint speed setting;
 n(T) = Setpoint speed;
 n(R) = Rated speed of the fan (Nameplate)

6.2.2 Determination of the Nominal Speed n (target) for a Given Speed Setpoint U (setpoint)

The speed setpoint can be determined using the following calculation:

$$n(T) = \frac{U(T)}{9.5} \times n(R)$$

6.3 Alarm Relay Characteristics



If no motor faults are detected, the relay will switch from COM-NC to COM-NO.

Be mindful of the relay contact status changes during the startup phase of the EC Motor.

The provided table illustrates the behavior of the alarm relay under various operational conditions of the EC Motor.

	NO - COM	NC - COM
Fan is connected to power supply, no fault detected	Open	Closed
Fan is connected to power supply, fault detected	Closed	Open
Fan is not connected to power supply	Open	Closed

7 Protective Features

The unit with EC motors includes monitoring functions to protect against:

- Mains undervoltage
- Mains overvoltage
- Locked rotor
- Electronics overheating
- Motor overheating
- Overcurrent protection
- Rotation detection

8 Maintenance, Repair

Our fans are maintenance free with normal operation! When using them in the fringe range simple maintenance work may be required!

Before any maintenance work is undertaken:

- Stop fan in accordance to regulations and disconnect all poles from mains supply.
- Wait until impeller is stationary!
- Make sure that restart is not possible!

Clean fan

- Clean impeller
- Keep the motor dry!
- Do not damage impeller, blades!



Only use usual commercial cleaning material paying attention to the prescribed safety measures and do not use any abrasive tools (surface protection will be destroyed!)

General controls

- Bearing play too large?
- Grease leaking on bearings?
- Surface protection affected by medium to be ventilated too aggressive?
- Unusual operation noise?
- Fan capacity for possibly exceeded duct system still sufficient causing overloading?



All fan maintenance tasks must adhere to the safety guidelines outlined in the Safety chapter.



Our factory ensures that all fans are both statically and dynamically balanced as a complete unit.

Ball Bearings

The integrated ball bearings are engineered to be maintenance-free, with a lifespan ranging from 20,000 to 40,000 hours under standard operating conditions. For preventive maintenance, it is advised to replace the ball bearings every five years due to grease aging.

If the fan experiences extended downtimes, particularly in humid environments, it is recommended to run the fans for at least one hour per month.

Semiannual inspections should be done to ensure the bearings remain quiet, easily movable, and free of play, which can be manually checked by rotating the rotor when the fan is inactive.



In situations where noise, stiffness, or noticeable play occurs in the ball bearings, replacement is necessary. For ball bearing replacements, please contact our service department.

When connecting the fan to the mains, hazardous voltages arise. Do not open the terminal cover within the first five minutes after disconnecting all power phases.

Cleaning

- Avoid using high-pressure cleaning equipment (such as steam cleaners).
- Do not employ acid, lye, surfactants, or solvents for cleaning.
- Refrain from using sharp or pointed objects during the cleaning process.



Before any repairs are undertaken, Please:



Stop fan in accordance to regulations and disconnect all poles from mains supply. Wait until impeller is stationary!



Make sure that restart is not possible!



Only use original spare parts manufactured and supplied by Wolter!

Change of motor impeller

- Disconnect electrical supply in junction box
- Unscrew motor mounting and pull out of the casing complete with motor impeller
- Install a new motor impeller complete with motor mounting in casing
- Connect electric supply

Control whether installation is correct

- motor impeller must rotate freely
- control whether direction of rotation is correct !
- Install maintenance cover if any!

9 Disposal



Please be aware of the relevant requirements and regulations in your country when disposing of the device. Wolter is committed to environmental protection and resource conservation, so environmentally friendly design, technical safety, and health protection were considered in the development of our fans. Below are our recommendations for the ecological disposal of the machine and its components.

9.1 Disassembly

When recycling and disposing of Wolter products, comply with local requirements.

Disassembly as follows:

- 1) Contact a local waste management company to clarify the dismantling process and required quality.
- 2) Disconnect the machine from the mains and remove all cables.
- 3) If necessary, remove and properly dispose of any liquids, such as oil, according to local regulations.
- 4) Transport the machine to an appropriate disassembly location.
- 5) Disassemble the machine following standard mechanical procedures.



The machine contains heavy parts that may fall during disassembly, risking serious injury and property damage.

Ensure all parts are secured against falling prior to their removal.

9.2 Disposal of Components

Components

The machine is primarily composed of metallic materials, which are generally recyclable. Separate the components according to these categories:

- Steel and Iron
- Aluminum
- Non-ferrous metals
- Insulating material (to be incinerated during copper recycling)
- Cables and wires
- Electrical scrap (if applicable)
- Plastics

Materials and chemicals

For materials and chemicals, dispose of them as follows:

- Grease
- Paint residues

Dispose of the separated components in accordance with local regulations. This includes any cloths and cleaning substances used during maintenance.

Packing Material

Waste Management and Packaging Regulations.

- For disposal or recycling needs, please contact a waste management company.
- Sea transportation wood packaging consists of treated wood. Please adhere to local regulations.
- Foam packaging, packaging films, and cartons can be directly supplied to material recovery facilities. Contaminated packaging materials can be delivered to thermal processing facilities.

10 Failure



Risks to life and limb!

The drive unit must operate smoothly and consistently at all speeds. Any equipment malfunction in the fan can lead to damage.



All fan maintenance work must comply with the safety protocols specified in the Maintenance chapter.

Any irregularities in the fan's operation indicate a possible fault and should be investigated by service personnel.

The table below details potential fault causes and corresponding actions to address them.

To Reset a Failure:

After an error has occurred, disconnect the main power supply for at least two minutes before attempting to restart the fan.

Test mode:

The fan should function correctly during the test run. Follow the procedures below:

- Turn off the main power supply.
- Ensure the control cable is connected.
- Switch on the main power supply.

The fan should operate at nominal speed.



The electronic housing is pre-installed at the factory. Only Wolter is authorized to perform modifications or repairs. Opening the housing will void the warranty. If repairs or replacements are needed, send the unit back to Wolter without making any modifications.

11 Troubleshooting

Alarm Priority:

- Critical failures will cause the fan to stop.
- Non-critical failures will limit the fan's power.

Symptom	Cause	Elimination	Critical / Non-Critical
Fan is not rotating or stops intermittently	No supply voltage present	Supply Voltage Check: <ul style="list-style-type: none"> • Measure the supply voltage directly at the fan. • If there is a fault, check the fuses and the wiring of the service switch 	-
	Missing setpoint	Verify the setpoint and its correct polarity	-
	Missing enable signal	Ensure the "GND" is correctly connected	-
	Internal protective feature has tripped	Over Voltage: <ul style="list-style-type: none"> • If the input voltage surpasses the specified tolerance limit • Check the main supply and fuses • The failure will reset automatically once the voltage falls below the maximum limit. 	C
		Locked Rotor: <ul style="list-style-type: none"> • Inspect the fan impeller for overload caused by dirt or foreign objects and attempt to turn it by hand. • Check the fastenings of the motor and nozzle. • Reset the failure 	C
		Motor Phase Error: <ul style="list-style-type: none"> • If a winding is interrupted or there is a wire break • Contact Wolter support 	C
		Motor Over Current (I Hi Alarm): <ul style="list-style-type: none"> • For motor-side short circuits • Contact Wolter support. 	C
Over Temperature (Motor): <ul style="list-style-type: none"> • Inspect the airflow and ambient temperature limits. • Ensure adequate cooling. • Check for overload on the fan impeller due to dirt or foreign objects. • Reset the failure 	C		
Fan turns but there is no or not enough airflow	Rotation speed of the fan too low	Refer to "Fan does not run at maximum speed"	-
	Airflow interrupted	Inspect the duct system (e.g., suction, filter, sealing caps)	-
	Calculated pressure does not match the real value	Verify the fan selection	-
	Unfavorable installation conditions	Installation situation. Refer to the section "Installation Recommendation."	-
	Due to external influences, the impeller rotates in the wrong direction	<ul style="list-style-type: none"> • Wrong rotation direction • Check the installation status and restart the fan to stop converting the airflow • Reset failure 	NC / C

Symptom	Cause	Elimination	Critical / Non-Critical
Fan does not run at maximum speed	Mains voltage too low	Under Voltage: <ul style="list-style-type: none"> The input voltage drops below the allowable limit of the specified mains voltage. Measure the mains voltage directly at the fan. In the event of an error, check the main supply and fuses. The failure will reset automatically once the voltage rises above the minimum limit. 	NC
	Missing phase	Input Phase Error: <ul style="list-style-type: none"> Check the mains voltage directly at the fan. If there is an error, inspect the fuses and the correct connection of the supply cable (e.g., service switch). The failure will reset automatically once the missing phase is restored. 	NC
	Excessive airflow or ambient temperature	Over Temperature (Electronics): <ul style="list-style-type: none"> Inspect the airflow and ambient temperature limits. Ensure sufficient cooling. 	NC
	Motor power limit reached	Motor current limit, I Hi limit <ul style="list-style-type: none"> Motor operates out of specification. Failure resets automatically after the value falls under the maximum limit. 	NC
	Maximum setpoint is not present	Check the setpoint based on the pin connection and increase.	-
	Setpoint is too high	Limit the setpoint based on the pin connection.	-
Vibrations or noises in the fan	Chafing of the impeller	Check impeller for dirt and clearance. Check mounting of impeller and inlet cone.	-
	Deformation	Stop fan immediately. Contact Wolter support.	-
	Dirty impeller	Clean impeller.	-
	Damaged ball bearings	Stop fan immediately. Contact Wolter support.	-
RCD Switch or fuse trips	Ground fault or short circuit	Check whether the cable is damaged or damped.	-
	Defective motor and / or electronic components	Contact Wolter support.	-

12 CE Marking

12.1 Declaration of Conformity

We hereby declare, under our sole responsibility, that Wolter products comply with all relevant EC/EU directives. A declaration of conformity has been prepared and is available for download on the Wolter website. The declaration is valid for fans connected as per the operating instructions and independently operated with sinusoidal current supply. The conformity declaration related to the ErP directive is valid only when combined with the ErP-related data on the product information and nameplate.

12.2 Declaration of Incorporation

Wolter products are considered incomplete machines under specific provisions. Consequently, a declaration of incorporation has been issued and is only valid for products mentioned in this manual. This document serves as an assembly instruction in accordance with the machinery directive, Annex VI, intended for "Professional" use.

EC Declaration of Incorporation

as defined by the EC-Machinery Directive 2006/42/EC

The manufacturer: Guangdong Wolter Chemco Ventilation Ltd.

No.69, Miao Bian Wang Road, Shipai, Dongguan, Guangdong, P.R.China

Hereby declares that the machine described in the following EC Directives:

Designation of the machine	Model or type of machine
In-Line Tube Fan:	RK-EC, RS-EC

meets the fundamental specifications outlined in the directive 2006/42/EC, specifically:

Annex I, 1.1.2, 1.1.5, 1.3.2, 1.4.1, 1.5.1, 1.7.3

Additionally, in compliance with the applicable directives:

- **Low Voltage Directive (2014/35/EU)**
- **EMC Directive (2014/30/EU)**
- **ErP Directive (2009/125/EC)**

Furthermore, we hereby state that the pertinent technical documentation, as per Appendix VI, Part B, has been utilized, and we commit to providing these documents to market regulators upon request, either in written form or electronically.

It is important to note that commissioning of the incomplete machine is strictly prohibited until it has been incorporated into a complete machine that fulfills the requirements of the EC Machinery Directive 2006/42/EC.

Date: 27.06.2022



Nicholas Ang
Vice President

Sales Network

Deutschland

Wolter GmbH.
Maschinen-und Apparatebau KG.
DE-76316 Malsch
T +49 (0) 72 04 / 92 01 0
F +49 (0) 72 04 / 92 01 11
info@wolter.eu

Europe

Denmark:

L.ØLAND VENTILATION A/S
DK-2605 Brøndby
T +45 (0) 70 / 20 19 11
salg@airforce.dk

Netherlands:

DE WIT Ventilatoren BV
NL-3821 CG Amersfoort
T +31 (0) 33 / 76 00 240
info@dewitventilatoren.nl

Sweden:

Nordisk Ventilator AB
SE-142 50 Skogås
T +46 (0) 8 / 72 70 250
se@nordiskventilator.se

Switzerland:

Anson AG Zürich
CH-8055 Zürich
T +41 (0) 44 / 46 11 111
F +41 (0) 44 / 46 13 111
info@anson.ch

OZ Tech SA

CH-1122 Romanel-sur-Morges
T +41 (0) 76 / 41 11 572
info@oztech.ch

United Kingdom:

Wolter (UK) Ltd.
GB-Leicestershire LE65 1AL
T +44 (0) 15 30 / 41 24 73
info@wolteruk.com

Middle East

UAE, Saudi Arabia, Qatar, Lebanon:

Please contact Wolter head office

Wolter GmbH.

Maschinen-und Apparatebau KG.
DE-76316 Malsch
T +49 (0) 72 04 / 92 01 0
F +49 (0) 72 04 / 92 01 11
info@wolter.eu

Asia

China:

Guangdong Wolter Chemco Ventilation Ltd.
Boluo, Huizhou, Guangdong

Dongguan Wolter Chemco Ventilation Ltd.

Shipai, Dongguan, Guangdong
T +86 (0) 769 / 8655 7298
F +86 (0) 769 / 8655 7278
info@wolter.com.hk

Taizhou Wolter Ventilation Co. Ltd.

Hengjie, Luqiao District,
Taizhou, Zhejiang
T +86 (0) 576 / 26 22 666 (26 52 888)
F +86 (0) 576 / 26 56 830

China - Hong Kong, Macau:

Wolter Asia Ltd
Kowloon, Hong Kong
T +852 (0) 2456 0198
F +852 (0) 2456 0290
info@wolter.com.hk

China - Taiwan:

Waxlink International Co., Ltd.
8F-2 No.218 Roosevelt Rd.,
Sec.6, Taipei, Taiwan
T +886 (0) 2 / 8932 1196
F +886 (0) 2 / 8932 1197
waxlink@mail.waxlinktw.com

India:

Wolter Ventilators India Pvt. Ltd.
867 D, Block-A, Sushant Lok, Phase-I,
Gurgaon - 122009 (Haryana)
T +91 (0) 124 2577797, 4261001-3
sales@wolterindia.in

Korea:

Kaceco-Wolter
14-1, Dang-dong, Gunpo-shi,
Gyeonggi-do
T +(82) 0 31 / 4773 104
F +(82) 0 31 / 4773 132
wolter@kaceco.com
info@kaceco.com

Malaysia:

Vibrantech (M) Sdn Bhd.
47200 Petaling Jaya Selangor
T +603 (0) 7847 3500
F +603 (0) 7847 3380
sales@vibrantech-sb.com

Singapore:

Wolter Pte. Ltd.
SG-569738 Singapore
T +65 (0) 63 / 52 95 48
F +65 (0) 63 / 52 95 47
info@wolterfans.com.sg

Thailand:

Wolter Ventilation Co., Ltd.
Thamai Kratumban Samutsakorn
741 10 Thailand
T +66 (0) 84 555 2936
kongsakol@wolterfan.com

Australia

The Sydney Fan Company.
NSW 2147, Sydney, Australia
T +61 (0) 2 / 9624 4000
F +61 (0) 2 / 9624 4100
sales@thesydneyfancompany.com

Wolter GmbH Maschinen-und Apparatebau KG

Am Wasen 11
DE-76316 Malsch / Germany
T +49 (0) 72 04 / 92 01 0
F +49 (0) 72 04 / 92 01 11
www.wolter.eu
info@wolter.eu

