

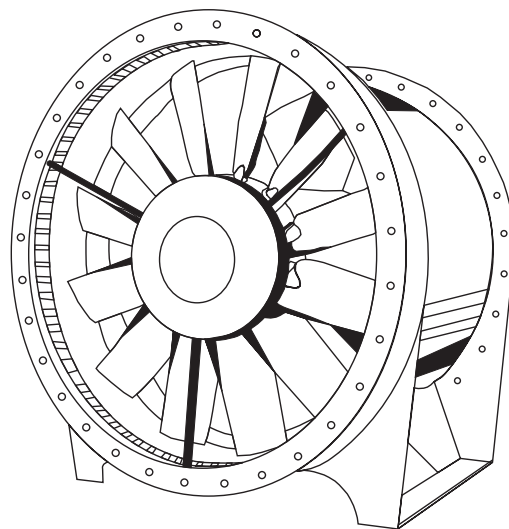

Operating Instructions for

JVT / RXJ / AXV / RXV

Tunnel Jet Fans and Axial Fans

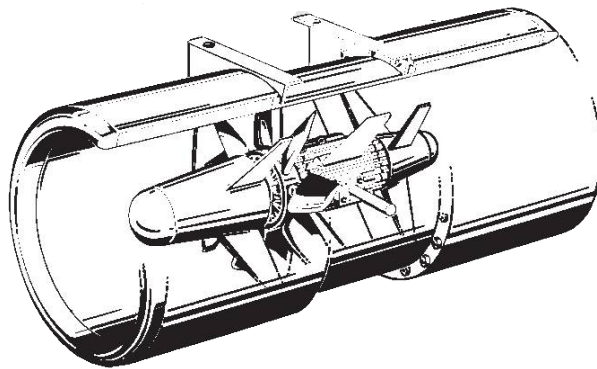

Guangdong Wolter Chemco Ventilation Ltd.

Jigongkeng Administrative Zone, Futian, Boluo, Huizhou, Guangdong, P.R.China. www.wolter.com.hk; info@wolter.com.hk

Dongguan Wolter Chemco Ventilation Ltd.

No.69, Miao Bian Wang Road, Shipai, Dongguan, Guangdong, P.R.China. Tel. +(86) 0769 8655 7298; Fax +(86) 0769 8655 7278

Contents

1	General safety notes.....	3
1.1	The Operator's Duty of Care	3
1.2	Explanation of Safety Symbols.....	3
1.3	Basic safety measures.....	3
1.4	Particular kinds of hazards.....	4
2	Product description.....	4
2.1	Stipulated usage.....	4
2.2	Construction.....	5
2.2.1	JVT / RXJ.....	5
2.2.2	AXV / RXV.....	5
2.2.3	Anti-surge System.....	5
2.3	Functional description.....	5
2.4	Technical Data.....	6
2.4.1	JVT / RXJ.....	6
2.4.2	AXV / RXV.....	7
3	EC Declaration of Conformity.....	8
4	Transportation and Storage.....	9
4.1	Transportation.....	9
4.2	Storage.....	9
4.3	Dimensions.....	10
5	Assembly.....	10
5.1	Common errors which occur during assembly.....	11
5.1.1	Inflow.....	11
5.1.2	Outflow.....	12
5.1.3	Bends.....	12
5.1.4	Changes in cross-sectional area.....	12
6	Initial Start up.....	13
6.1	Checks prior to initial start-up.....	14
6.2	Starting up the fan for the first time.....	14
6.3	Checks after initial start-up.....	14
7	Help with Malfunctions.....	15
7.1	Tabular overview of possible malfunctions and aids in eliminating those malfunctions.....	15
8	Maintenance.....	17
8.1	Surface protection.....	17
8.2	Vibration Monitoring.....	17
8.3	Bearings.....	18
8.3.1	Monitoring of bearings.....	18
8.3.2	Additional instructions for various fan bearing types.....	19
8.4	Functional description and mounting instruction for impellers and pulleys having taper lock bushes.....	19
8.5	Operation at higher temperatures (> 70 deg. C) / Smoke proof design F200 / F300 / F400 (EN 12101-3).....	20
8.6	ATEX- fans - general instructions, additional standards and instructions.....	21
8.7	Servicing.....	22
8.8	Overhaul.....	23
8.8.1	Dismantling the rotor.....	23
8.8.2	Assembling the rotor.....	24
8.8.3	Maintenance of anti-friction bearings.....	24
8.8.4	Instructions on correct bearing replacement.....	26
8.8.5	Electrical Motor and its connection.....	26
9	Tunnel Fans.....	27
9.1	Description.....	27
9.2	Assembly.....	27
9.3	Common mounting errors.....	28
9.4	Nameplate.....	28
9.5	Operation: Starting, stopping/ reversal.....	29
9.6	Operational safety.....	29
9.7	Recommended safety checks.....	29
10	Commissioning checklist.....	30
11	Instructions regarding special types of dangers.....	32
11.1	Electrical energy.....	32
11.2	Gas, dust, steam, smoke.....	32
11.3	Hydraulics, pneumatics.....	33
11.4	Noise.....	33
11.5	Oils, grease and other chemical substances.....	33
11.6	Portable machines (Machines used at different locations).....	33

1 General safety notes

1.1 The Operator's Duty of Care

The tunnel fans have been constructed and built whilst taking into account an analysis of the hazards involved, and after careful selection of the harmonised standards to be observed, as well as other further technical specifications. They thus correspond to the current level of technology and guarantee a high degree of safety.

However in operational practice, this level of safety can only then be attained if all required measures are taken. It is incumbent upon the operator's duty of care to plan these measures and to monitor their execution.

In particular, the operator must ensure that

- the fan is only used as stipulated (cf. chapter, „Product Description“)
- the fan is only operated in a faultless and functional condition and that safety fittings, especially, are regularly examined with respect to their functionality
- the operating instructions are always maintained in a readable condition and are available at the fan's location of deployment in their entirety
- only sufficiently qualified and authorised personnel operate, maintain and repair the machine
- these members of personnel are familiar with the operating instructions and especially the safety notes contained therein
- no safety and warning signs fitted to the fan are removed, and that they are kept in a readable condition.

1.2 Explanation of Safety Symbols

The following symbols are used in these operating instructions. These symbols are, above all, intended to draw the reader's attention to the text contained in the adjacent safety note.



Warning

This symbol indicates that dangers exist which are hazardous to life and health



Mortal danger

Electrical hazard. Serious and also fatal injury can result if these notes are disregarded.



Note

Indicates user tips and other useful advice.

1.3 Basic safety measures

Wolter tunnel fans are, at the moment of delivery, manufactured to the current level of technology.

Extensive materials, function and quality checks assure them of a high level of usefulness and long service life! Nevertheless, these machines can be dangerous if they are improperly used by untrained personnel or are used in a non-stipulated manner.



- Read these operating instructions carefully before putting the fans into operation!
- Only operate the fan in its enclosed state or with properly assembled protective anti-intrusion fittings, or with protective screens. (We can supply suitable, tested protective screens on request!)



- Assembly, electrical connection and maintenance may only be carried out by trained craftsmen!

- Only operate the fan in the manner stipulated and within the specified output limits (see rating plate) and with approved conveyed media!

1.4 Particular kinds of hazards

The tunnel fans are axial fans. In this respect, particular hazards are caused by the rotor and through the flow of air, which can, at times, be considerable. For this reason the following points are to be observed:

- Never reach into the rotor when it is rotating. Do not try to use your hand as a brake for the rotor during maintenance work.
- Loose clothing or light parts can be sucked in by the draught of air. That is why you should always wear tight-fitting clothing during maintenance work and during free-suction operation.
- Larger items (tools etc.) can obstruct or totally ruin the rotor. For this reason you should always fit a protective screen during free-suction or free-blowing operation.

2 Product description

2.1 Stipulated usage

Our axial fans have been specially developed for use in modern ventilation and air conditioning systems. The rotors are statically and dynamically balanced at the factory, and manufacture is subject to the strictest intermediate and end checks and is certified in accordance with DIN / EN / ISO 9001.

Conditions of use

The air should correspond to tender specifications, as the corresponding components are determined for this. If these are not listed in more detail, then the following applies:

The tunnel fans are suitable for the conveyance of

- clean air
- air which has little dust and grease content
- gases and vapours which are only slightly aggressive in nature
- media up to a maximum air density of 1.3 kg/m³
- flow volumes at temperatures ranging from - 30 °C to + 60 °C
- media up to a max. humidity of 95%

Conditions of fitting

- The fan must either be built into a ducting channel or have suction and outflow protection elements fitted to it. The fans are not designated for any types of usage other than those cited here, and any such use shall be considered as improper usage!



In particular, we especially draw your attention to the following points. Non-compliance can either result in considerable material damage or personal injury, or that the demanded fan output values are not attained.

- The fan may not be operated without the necessary safety fittings. Should there be no ducting channel connected at one end, e.g. the suction end, then a protective screen must be fitted at that end in order to prevent access to rotating parts.
- In order to avoid any damage to the fan and specially to the rotor vanes, you must prevent the possibility of loose parts being sucked in by the fan or of other items being able to find their way into the fan. The fitting notes regarding intake and outlet flow conditions are to be observed.

2.2 Construction

2.2.1 JVT / RXJ

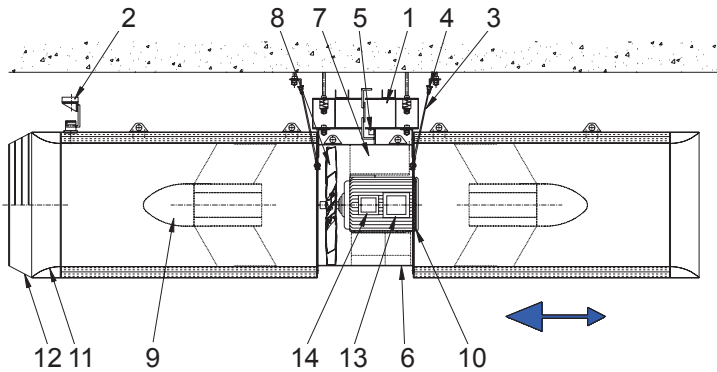

The tunnel jet fan consists of the following main parts:

- (1) Suspending construction
- (2) Anti-swing device (optional/ for silencer length > 1500 mm)
- (3) Catch ropes / Securing chains (depending on size 2,4, 6 or 8 pieces)
- (4) Mounting bracket for catch ropes / securing chains
- (5) Tear-off monitoring (electrical switch)
- (6) Jet fan housing
- (7) Guide vane
- (8) Impeller
- (9) Pre-guide vane
- (10) Motor
- (11) Suction nozzle or silencer (one side or both sides)
- (12) Protection grill (one side or both sides)
- (13) Junction box
- (14) Auxiliary junction box (if required)
- (Optional components: 1/2/3/4/5/11//12/14)

2.2.2 AXV / RXV

The AXV / RXV axial jet fan consists of the following main parts:

- (1) Motor
- (2) Guide vane
- (3) Impeller
- (4) Anti-surge system
- (5) Space section
- (6) Front rectifier
- (7) Grease nipple
- (8) Terminal box
- (9) Vibration absorber



2.2.3 Anti-surge System

Anti surge system with anti stall ring helps to ensure stable operation under all conditions especially when subjected to severe aero-dynamic loads. These rings are available upon request.

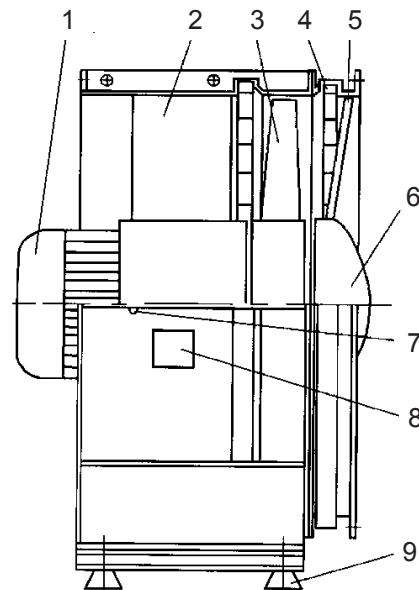

2.3 Functional description

The fan sucks air from the ducting on the suction side through the rotating rotor and conveys this air in the axial direction to the outflow side via the motor. The motor is positioned in the air flow and is cooled by the flow.

Control and regulation of the system is carried out by an external control unit. This does not form part of the fan itself. The corresponding operating instructions are to be consulted with regard to the control unit's operation. The fan itself requires no operation when it is running.

2.4 Technical Data

2.4.1 JVT / RXJ

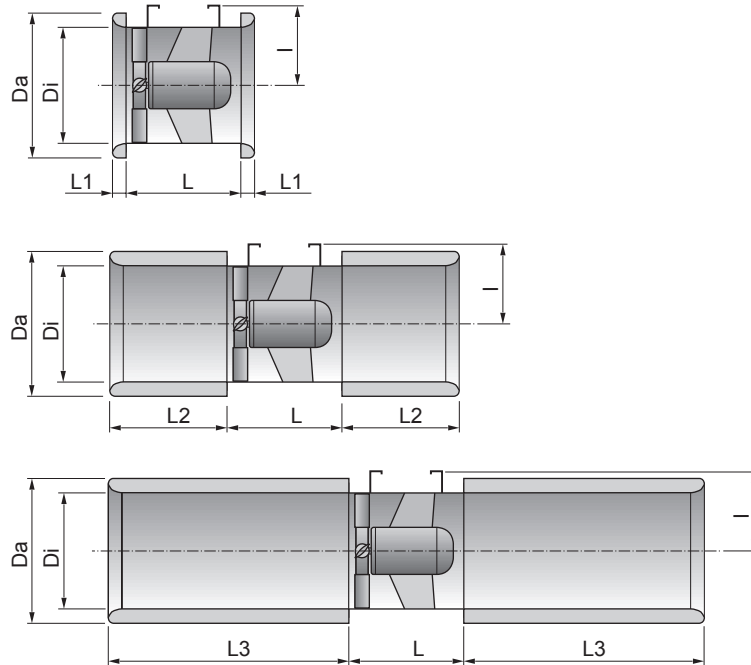

Größe size	L [mm]	Di [mm]	Da [mm]	l [mm]	L1 [mm]	⚖ [kg]	L2 [mm]	⚖ [kg]	L3 [mm]	⚖ [kg]
560	700	560	710	365	80	225	640	290	1200	390
630	700	630	780	400	80	250	710	340	1340	450
710	565	710	860	450	100	400	810	495	1520	690
800	700	800	1000	510	100	320	900	430	1700	640
900	700	900	1100	560	120	380	1020	525	1920	790
1000	780	1000	1200	610	140	620	1140	800	2140	1170
1120	1000	1120	1320	710	160	740	1280	920	2400	1340
1250	1000	1250	1450	800	160	830	1410	1100	2660	1550

2.4.2 AXV / RXV

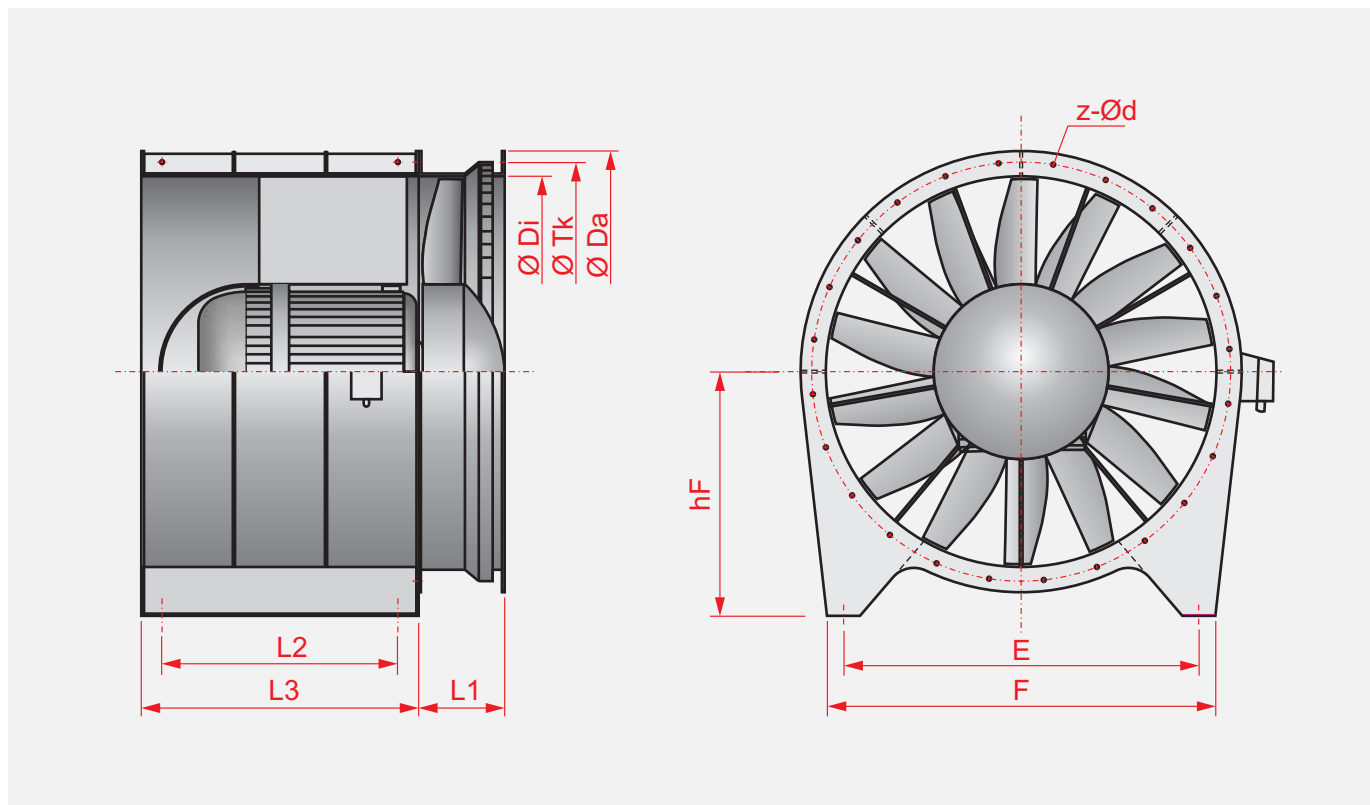

Größe size	Da [mm]	Di [mm]	hF [mm]	z x d [mm]	Tk [mm]	E [mm]	F [mm]	L1 [mm]	L2 [mm]	L3 [mm]
1400	1590	1408	880	20 x 18	1510	1280	1400	310	850	1000
1500	1690	1508	980	24 x 18	1610	1380	1500	335	1000	1165
1600	1790	1608	1050	24 x 18	1710	1460	1600	355	980	1150
1800	2010	1810	1120	24 x 18	1920	1660	1800	400	1200	1400
2000	2210	2010	1165	32 x 18	2120	1820	2000	445	1300	1550
2100	2340	2110	1215	32 x 18	2240	1880	2100	465	1350	1600
2200	2440	2210	1265	32 x 18	2340	2020	2200	490	1400	1650
2400	2630	2410	1445	34 x 22	2530	2350	2550	550	1500	1820
2500	2740	2511	1420	36 x 24	2640	2320	2500	555	1530	1800
2600	2840	2612	1470	36 x 24	2740	2380	2600	590	1580	1850
2800	3150	2815	1570	36 x 24	3000	2500	2800	1300	1680	1900

3 EC Declaration of Conformity

in accordance with Appendix II A of the EC Machinery Directive (89/392/EWG)

The manufacturer:

Wolter Asia Ltd.

Unit A4, 3rd floor, Merit Industrial Centre,
No.94 To Kwa Wan Road, Kowloon, Hong Kong

Guangdong Wolter Chemco Ventilation Ltd.

Jigongkeng Administrative Zone, Futian Town,
Boluo, Huizhou City, Guangdong Province,
P.R.China

Hereby declares that the machine described in the following:

Fans of the JVT / RXJ / AXV / RXV series

Meets the health and safety requirements of the following EC Directives:

**In accordance with Machinery Directive (98/37/EG),
Appendix II A
in accordance with the Low Voltage Directive
(73/23/EWG)**

Harmonised standards applied:

DIN EN 60335-2-2	Safety of electrical equipment for household use and similar purposes; Part 2: Special requirements for dust and water suction machinery.
DIN EN 60335-2-80	Safety of electrical equipment for household use and similar purposes; Part 2: Special requirements for fans.
DIN VDE 0700-220	Safety of electrical equipment for household use and similar purposes; Fans and associated control units for use on ships.
DIN EN 1037	Machine safety; Avoiding the unexpected start up of the machinery.
DIN EN 1088	Machine safety; Locking systems in combination with detachable protective fittings; Guiding principles for layout and selection.
DIN EN 292-1	Machine safety; Basic terms, general guiding principles of layout; Part 1: Basic terminology, methodology.
DIN EN 294	Machine safety; Safety distances for the prevention of upper limbs coming into the vicinity of danger areas.
DIN EN 811	Machine safety; Safety distances for the prevention of lower limbs coming into the vicinity of danger areas.
DIN EN ISO 11200	Acoustics; Noise irradiation of machines and appliances; Guidelines on the application of basic standards for establishing noise emission levels at the workplace and at other fixed locations (ISO 11200:1995)

Any changes in construction which have an effect on the technical data specified in the operating instructions and on the machinery's stipulated usage, i.e. those changes which essentially change the machine, shall invalidate its declaration of conformity!

Date: 15.06.2022



Nicholas Ang
Vice President

4 Transportation and Storage

4.1 Transportation

Wolter fans are packed at the factory to suit the respectively agreed mode of transportation.

Transport the fan in its original packaging. Only use suitable means of transport, such as pallet trucks or fork-lift trucks.

If the fan is to be transported by hand, ensure that supporting and carrying loads are kept within reasonable limits for the personnel involved.



The following special hazards must be taken into account when transporting the equipment:

- The transportation packaging does not prevent damage to the equipment through improper transportation. The fans must not be dropped or thrown.



- Sharp, protruding edges can lead to injury through cuts. Suspended loads can fall, which then constitutes a fatal hazard - stand clear of suspended loads!

- Parts that have been stacked too high can collapse. If load-carrying devices other than those specified here are used, this can cause serious damage to the machine.
- A risk of fire exists due to the easily flammable nature of the packaging materials - do not use naked flames and do not smoke!
- Read the chapter, "General Safety Notes".

4.2 Storage

Store the fan in a dry, weather-protected location in its original packaging or protect it from the effects of dirt and the weather until final assembly. Cover open pallets with tarpaulin sheets and protect the fans from the effects of dirt and contaminants (e.g. swarf, stones, wire etc.)

Avoid extremes of cold and heat.

Avoid lengthy storage periods (a maximum of one year is recommended) and check that the motor bearing assembly is in good functional order prior to fitting.

Care must be taken to ensure protection against moisture and dust. Large variation in temperatures must be avoided. Otherwise it might result in damage to electric motors, cable boxes, bearings, painted surfaces and seals. It must be noted that not all paints are weather resistant, e.g. mild corrosion may be caused by only a primer.

Prolonged downtime may reduce the lubrication properties of grease or oil. It could lead to corrosion of the bearings. Ball bearings can develop pits. The shaft seal rings may become dry and the belts may become brittle. In order to avoid this, the fan should be operated **for about ten minutes once in 1-2 months** and if not, at least the impeller must be turned by hand. The grease in the bearings must be changed once in 3 years. If it's not thoroughly maintained, then all the bearings must be changed after 3 years of downtime.

Precautions against accidental power supply

The operator must take appropriate measures and provide appropriate elements to avoid accidental power supply to the fan and to the accessories, especially during maintenance and mounting tasks. In order to do so, electrical power supply as well as other energy sources such as hydraulic, pneumatic, potential energy spring loads and draft in the duct system must be taken into consideration. The operator must be provided with separation, switching, grounding and net locking gear to prevent accidental connection to power. The operator must comply with EN 1037: "Safety of machines - Avoiding accidental start-up".

Long-term storage

In addition to the listed tasks the following activities must be carried out:

- The fan bearing must be filled completely with grease when it is being lubricated.
- The fan bearing must be filled with preservative oil during lubrication.
- The belts of the belt drive must be loosened.

- A signboard marked as "not in operation" must be put up.
- Inlet and exhaust openings must be closed airtight.

Commissioning after a long term storage

- After a long intermediate storage, a pre-check must be conducted to check for the presence of any faults before mounting the fan.
- Topping up the grease or the oil of the fan bearing must be carried out to allow the machine to be operational.
- Motor and fan bearing must be checked for its faultless status (vibration measurement) with the help of a trial run and if necessary must be changed.
- Fans with special sealing requirements must be checked and defective seals must be changed.
- The belts must be tightened.
- Inlet and exhaust coverings must be removed.
- The bearings must be changed, if the fan is left idle for a prolonged period of time (max after 3 years).

Storage instruction for spare reserve and abrasive parts

All the parts should be stored in a room at 15 - 25°C with a relative humidity of maximum 70%. Variations in the temperature should be limited to max. 1°C per hour. Roller bearings are delivered in the original packing of the manufacturer. The maximum storage time is two years. After one year the bearings have to be exchanged. Rubber or rubber coated spare parts such as radial packing rings, O-rings, flexible connectors, dampers and v-belts have to be protected against light and sealed in plastic wrapping. The parts should be checked for their elasticity and brittleness every year. The maximum storage is five years or less according to the manufacturer's instructions. Metallic parts such as impellers, shafts, bushes, pulleys and bearing housings have to be checked every year. If necessary, the preservation of processed surfaces has to be corrected if necessary. The bare metallic parts have to be lubricated.

4.3 Dimensions

See chapter, " Technical Data "

5 Assembly

After delivery, immediately check for external damages. Care must be taken that the fans are not mechanically deformed or subject to unwanted forces in order to prevent jamming or grinding of the impeller.

While using vibration dampers, they must be placed such that a uniform load (deflection) is obtained, and it may be necessary to insert shims. When the fans are installed the damper must not be canted, dragged over the floor or stressed on one side only; this could damage the rubber or the springs.

Flexible connections must be installed in such a way that they allow the fan to have free movement especially during the start-up. On the other hand they should not be too compressed or misaligned that they form folds that could impede the airflow. In case of high pressure and danger of abrasion, guide rings (ducts) must be provided.

The fan must be connected to the motor according to the connection diagram in the terminal box and according to the instructions of the manufacturer. All motors are to be protected with the help of motor protection devices.

Before commissioning, all the sensors and inspection devices must be connected and it must be ensured that the fan is disconnected during a given signal. In the construction planning and during the connection it must be ensured that a functional disturbance or cable disruption of a sensor is identified through a plant control and is interpreted as an alarm if required.

During the commissioning and the trial run, all the executed controls and tasks must be recorded.



Assembly and electrical work is only to be carried out by trained and instructed craftsmen and in accordance with the respectively applicable regulations!



The following points are to be observed when assembling the fan:

- Secure the fan to the assembly base plates.
- The fans must not be deformed or twisted during fitting! Use spacing plates if the need arise.
- The fitting position agreed in the lay-out is to be observed
- Only self-locking screws may be used for securing the outflow flange
- Make the electrical connection as per the enclosed terminal plan in the motor connection cabinet of terminal cabinet housing.



Attention: Make the electrical connection in accordance with the technical connection conditions and the relevant regulations!

- Feed in and seal the cable into the connection cabinet properly.
- If available, connect the thermistor / thermo-contact for motor protection, otherwise the warranty lapses.



Before checking the direction of travel:

- Remove foreign bodies from the fan area
- Assemble contact protector, protective screen (see accessories), or box in fan
- Turn the rotor through a few revolutions by hand in order to test its ease of movement
- Check the direction of travel in accordance with the arrow on the housing by switching on and off very quickly
- If necessary, alter the direction of travel for AC motors by swapping 2 phases. In the case of single-phase motors, reverse the direction of travel by swapping Z1 with Z2 (attention: the direction of current flow in the auxiliary winding also changes)

5.1 Common errors which occur during assembly

5.1.1 Inflow

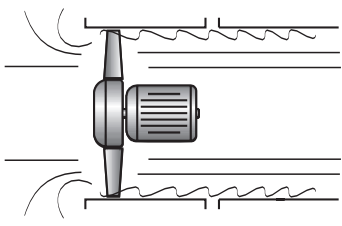
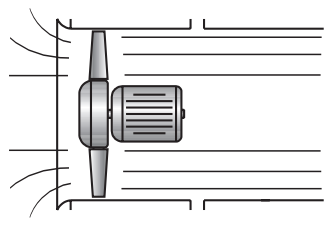
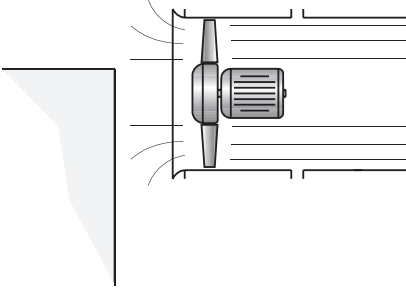
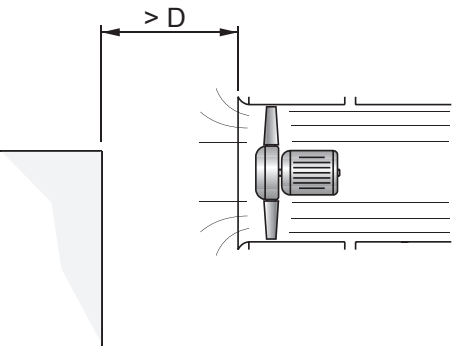
Incorrect	Correct
 <p>INCORRECT: No intake nozzle – Result: The vane edges are not in the air flow, the air output is reduced, noise output becomes greater. This can cause permanent damage to the rotor blades.</p>	 <p>RECOMMENDED: The intake nozzle enables an even flow to be achieved over the whole cross-sectional area.</p>
 <p>INCORRECT: The fan output is reduced if an obstacle is situated too close to the intake.</p>	 <p>RECOMMENDED: The distance must be at least as great as the fan diameter.</p>

5.1.2 Outflow

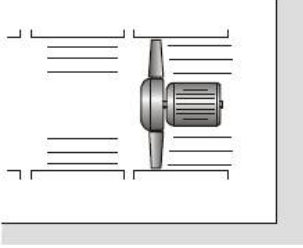
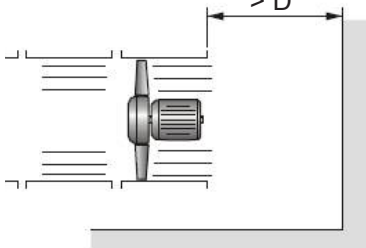
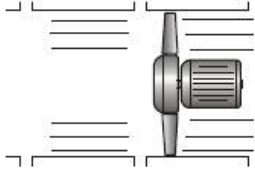
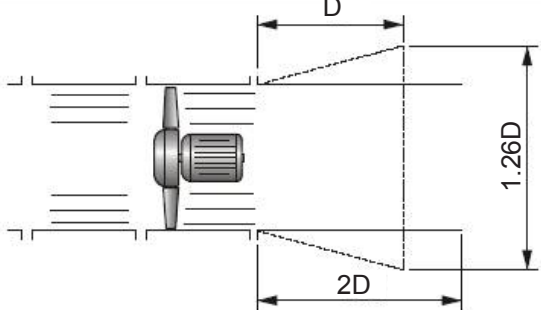
Incorrect	Correct
 <p data-bbox="108 609 710 672">INCORRECT: Any blockage of the outflow must be prevented.</p>	 <p data-bbox="794 609 1412 672">RECOMMENDED: The distance must at least be as great as the fan diameter.</p>
 <p data-bbox="108 1016 678 1079">INCORRECT: The outflow should not end at the same point as the fan.</p>	 <p data-bbox="794 1016 1444 1111">RECOMMENDED: An outflow passage having a length of $2xD$, or an outflow diffuser, as shown, both reduce outflow losses.</p>

5.1.3 Bends

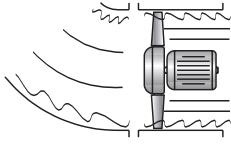
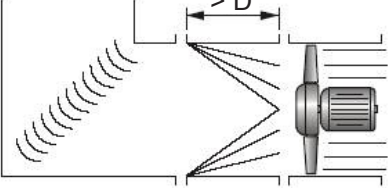
Incorrect	Correct
 <p data-bbox="108 1487 758 1574">INCORRECT: Bends with a small radius of curvature reduce fan output and increase noise levels if fitted too close in front of the vane.</p>	 <p data-bbox="794 1487 1396 1550">RECOMMENDED: A quadratic channel corner with short guide vanes is preferred.</p>

5.1.4 Changes in cross-sectional area

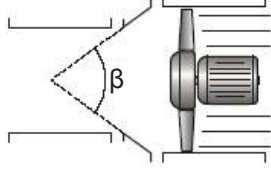
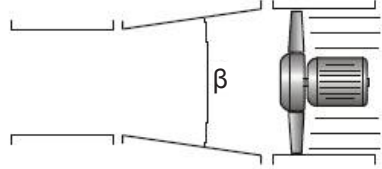
Incorrect	Correct
 <p data-bbox="108 1944 710 2007">INCORRECT: Diffusers or nozzles having an angle greater than 30° should not be used.</p>	 <p data-bbox="794 1944 1444 2007">RECOMMENDED: If possible the angle should be less than 15°.</p>

6 Initial Start up

The following points are to be observed in order to avoid damage to the machinery or life-threatening injury during initial start-up:

An arrow on the fan casing, fan protection or motor indicates the rotational direction of the fan.

Some big axial fans may be throttled appropriately; otherwise the motor can be overloaded. The reverse is true for axial fans. With free outlet they absorb less power than when throttled.

Before the rotation direction is reversed, the impeller must come to a complete standstill. The high moment of inertia can otherwise lead to damage

- Only qualified personnel may carry out the machine's initial start-up and this must take place in compliance with the safety notes.
- Prior to initial start-up, check that all tools and foreign bodies have been removed from the machine.
- Activate all safety devices and Emergency Stop switches prior to initial start-up.
- Check the motor's direction of travel prior to initial start-up.
- Read the chapter, "General Safety Notes ".

Mechanical safety

To prevent any contact between moving parts, safety devices must be installed. If they are not supplied as an integral part of the fan, they must be installed on site. This especially is applicable for inlets, outlets and access doors which must be secured on site.

Fans with belt drive

The belts must be checked to ensure they run smoothly The bearing temperature must be monitored. The temperature on the bearing housing will normally rise to 50-60 °C (warm to the touch), rarely to 70 °C or more. Be careful while touching! If the temperature rises to higher values, the system must be restarted after a cooling down period and subsequently the probable cause for the fault must be found and eliminated. The belts are to be tightly tied. It must verify that the bearings are good but not excessively lubricated.

Systems with dampers

Dampers that can interrupt the airflow completely must be connected in such a manner that the fan is automatically stopped immediately after closing the damper. Otherwise an excessive heating of the fan and excessive vibrations can occur.

Fans operating in parallel

When multiple fans are connected in parallel ensure that the non-operating fans are not rotating in the direction opposite to their intended rotational direction. Starting the fan rotating in the wrong direction can otherwise lead to overload of the power supply and motor and cause damages to the blades. Special care must be taken while carrying out maintenance activities. The impeller has to be mechanically blocked before starting any of the activities at the fan.

Maximum speed, different speeds and speed control.

The fan should not be operated at higher speeds than those stated in the data sheet.

A speed reduction is permissible only in consultation with Wolter. It must be ensured that the fan is not going to operate at a resonance frequency which can damage the fan or associated components. While controlling the speed it must be taken into account that individual frequencies of different components of fan are achieved **in the range of minimum to the maximum speed. At these corresponding speeds no permanent operation may occur.** While starting the system the variable speed control must be programmed so that these resonance speeds are quickly bypassed.

Motor protection switch

Fans have a relatively high moment of inertia. In most cases for heavy start relays are necessary. While selecting and setting the relays the whole operating range must be considered. For example a fan motor will draw 16% more current when the feed medium going through the fan is at -20° C than at 20° C because of higher atmospheric density.

Starting couplings

To avoid excessive heating and overloading of the coupling, a maximum of only 4 starts per hour is permissible. Between any 2 starts a cooling period of at least 10 minutes is required.

Explosion-proof fans

Very special care must be taken. In addition to other instructions the following must be noted. **The build-up of electrostatic charges must be avoided by grounding all relevant parts. Special care must be taken to ensure that there is adequate distance between rotating and non-rotating parts and the motors at no point become overloaded or overheated.**

6.1 Checks prior to initial start-up

Proceed with the fan's initial start-up in the following sequence:

- Check that the mechanical assembly has been carried out properly
- Remove foreign bodies located in the suction and outflow areas and in the fan space
- 
 - Check that the electrical installation has been completed in accordance with regulation
 - Does the mains voltage match the motor voltage specified on the rating plate?
 - Is the switchgear used suitable for the motor both with respect to the switching functions to be carried out and also to the switching conditions and switched output of the motor?
- Is the motor protection system set correctly with regard to the motor's nominal current? The setting must be carried out in accordance with the corresponding details contained on the motor output plate.
- Has the motor been connected correctly in accordance with the wiring diagram?
The connection schematic supplied by the motor suppliers applies for the connection of the motor.
The special connection regulations are to be observed for explosion-protected models.



Accident prevention

Protective anti-intrusion fittings, protective screens (see accessories) mounted, fan boxed in or assembled out of reach. If the fan is assembled for free suction, a protective screen must cover the suction aperture. This is the only way that the accident prevention regulation governing protection from contact has been deemed to be met.

6.2 Starting up the fan for the first time

Only put the fan into operation after it has been assembled in accordance with the regulations!

- Put the fan into operation.
- Monitor its correct function (quiet running, vibration, imbalance, power consumption, controllability) Should the required output (volume flow or pressure increase) not be achieved by the fan, e.g. through unforeseen changes in the installation system, the rotor fins can be adjusted up to the maximum fin settings specified both on the rating plate and in the technical documentation. The power consumption must be re-measured in order to avoid any possible motor overloading. The thermo-protection system may be activated if the motor power consumption is too high!
- Check the bearing temperature after a lengthy period of operation
- Always keep suction openings clear! Check protective screens or protective anti-intrusion fittings for dirt, and clean if necessary!

6.3 Checks after initial start-up

Check the mechanical connections after initial start-up, especially the joints at the fan.

7 Help with Malfunctions

The following points must be observed in order to avoid damage to the machinery or life-threatening injury when eliminating machine malfunctions:

- Only eliminate any malfunction if you have the specified qualifications necessary for the task.
- First of all ensure that the machine cannot be switched on inadvertently, by locking the equipment's off switch or control cabinet by means of a padlock.
- Secure the hazardous area with respect to moving machine parts.
- Read the chapter, "General Safety Notes".

7.1 Tabular overview of possible malfunctions and aids in eliminating those malfunctions

Problem	Cause	Elimination
Motor or motor control system switches off	Motor too hot, thermo-contact activates.	Allow the motor to cool off. Depending upon the control equipment in use, the fan will either start itself up or will have to be re-started again. Check whether: <ul style="list-style-type: none"> - The conveyed medium is too hot - All phases are evenly loaded and connected - Operating point does not match the lay-out - Rotor blocked
Air output incorrect	Incorrect direction of travel of the fan	Change the direction of travel (see electrical assembly)
	Fan assembled incorrectly	Either the rotor is incorrectly mounted on the motor shaft or the whole fan has been incorrectly fitted into the installation. Switch off the fan. Correct the incorrect assembly (rotor or complete fan).
	Rotor blocked	Switch off the fan. Remove the blockage. Ensure that the accident prevention regulations are observed in the process.
	Rotor defective	Switch off the fan. Dismantle the rotor and fit a new one.
	Lay-out does not match installation resistance	Clean or replace filters if dirty; In the event of an erroneous lay-out, the fan's output can be altered by changing the vane angle within limits. In this case the shaft output must be checked for the required vane, so that the motor is not overloaded. The rotor should be re-balanced after any alteration to the vane angle.
Fan is labouring under load, air flow is periodically interrupted	Fan is operating within an unfavourable characteristic curve range	If possible, reduce the installation resistance. If this laboured operation of the fan continues over a prolonged period, the rotor will be ruined!

Problem	Probable causes	Measure	Elimination
Too less volume flow	False direction of rotation Pressure higher than specified Rotational speed is too less Ducts are blocked Impeller is dirty	Shutdown Consult & shutdown Consult & shutdown Shutdown Shutdown	Check the motor connection Check the construction Adjust the rotational speed Clean the cables Clean the impeller
Very low pressure	False direction of rotation Volume flow is higher than spec. Density is lower than specified Rotational speed is too less Leakage in the fan Leakage in the system	Shutdown Consult & shutdown Consult & shutdown Consult & shutdown Shutdown Shutdown	Check the motor connection Check the construction Check the construction Adjust the rotational speed Change sealing Change sealing
Very high power	False direction of rotation	Consult & shutdown	Check the motor connection
Consumption	Volume flow is higher than spec. Pressure is lower than specified Density is higher than specified Rotational speed is high	Consult & shutdown Consult & shutdown Consult & shutdown Shutdown	Check the construction Check the construction Check the construction Adjust the rotational speed
Abnormal noises	Impeller grazes Defective sealing Contaminants in the casing	Shutdown Shutdown Shutdown	Check the Impeller/gap Change the sealing Eliminate contaminants Check for damages
	Bearing damages Loose clamp screws	Shutdown Shutdown	Repair Change the bearing Re-tighten the screws
Vibrations	Imbalance False direction of rotation Equipment defect Very high rotational speed Bearing damages Turbulences in the System Turbulences in the fan Loose clamp screws	Shutdown Shutdown Shutdown Shutdown Shutdown Consult & shutdown Consult & shutdown Shutdown	Clean the impeller, balancing Check the motor connection Align Check the rotational speed Change the bearing Check the air duct in the System Check the design/execution Re-tighten the screws
Rotational speed is too low	Slacking of the belt drive False transmission Motor overloaded	Consult & shutdown Consult & shutdown Shutdown	Tighten the belt or change Adjust the transmission Check the design
High bearing temperature	Too much grease/oil in the bearing	Shutdown	Adjust the grease/oil quantity
	Wrong grease/oil in the bearing Damaged bearings	Shutdown Shutdown	Change the grease/oil brands Change the bearing
	Very high temperature of the environment	Consult & shutdown	Cool down
Gas Odor	Defect of the shaft seal Defect of the casing seal Defect of the cable seal Crack in the casing or cables	Shutdown Shutdown Shutdown Shutdown	Change the shaft seal Change the seals Change the seals Repair

If there are problems not listed above, please kindly shutdown the system and contact us.

8 Maintenance

The following safety notes must be observed when maintaining the machine - life-threatening injuries to personnel, damage to the machine and other material damage, as well as environmental damage, can be avoided.

- Cleaning, lubrication and maintenance work may only be carried out by authorized operating personnel - operating instructions are to be observed.
- Repair work may only be carried out by authorized craftsmen - accident prevention regulations are to be observed.
- Secure the operational area over a large area prior to the commencement of maintenance work.
- The specified sequence of the working stages is to be observed exactly.
- Only Trained electricians can carry out electrical work on the machine's electrical equipment
- Self-locking screws and nuts are always to be renewed.
- All specified screw torque settings are to be observed precisely.
- Read the chapter, "General Safety Notes".

All impellers have been carefully balanced at the factory premises itself. Imbalance can occur due to dust, wear, abrasion and accumulation of material on the impeller leading to vibrations and damage of bearings. Therefore an operation free of vibrations must be ensured.

8.1 Surface protection

The surface protection of a component must be regularly checked and maintained if necessary. In particular, mechanical damage to the surface due to dust or chemical impact must be identified. Even stainless steel materials can be subjected to surface corrosion, e.g. when it is operating under a very moist and salty environment or aggressive gases are present.

In order to ensure that surface corrosion neither affects the general properties of the fan nor result in a situation whereby maintenance activities are urgently required, regular and suitable maintenance tasks within the period of warranty should be carried out. Corrosion can be prevented typically by cleaning the surface and by using a suitable surface conservation technique.

8.2 Vibration Monitoring

For safe operation, installation of vibration sensors are always recommended.

The increase of vibration level is always a dangerous signal.

The change of vibration can be monitored by measuring the mechanical vibration of the bearing and motor.

The continuous vibration value measured can be well monitored. Through long-term vibration monitoring, the change of fan operating conditions can be found at early stage and can be corrected if necessary. As such the equipment damage can be avoided and necessary maintenance work can be planned economically and effectively. If there are any significant changes on the vibration value, the causes can be checked ie improper installation, dirt accumulation, wear on the impeller or other components etc.

The vibration may be caused by motor misalignment, rotor imbalance, bearing defects, greasing or lubrication problems, etc

For fans, vibration can be due to unbalance, blade through frequency, turbulence, motor, belt drive, belt natural frequency, base mounting isolator etc

NB: Vibration severity range limits (ISO 2372) and balance and vibration application categories (ISO 14694).

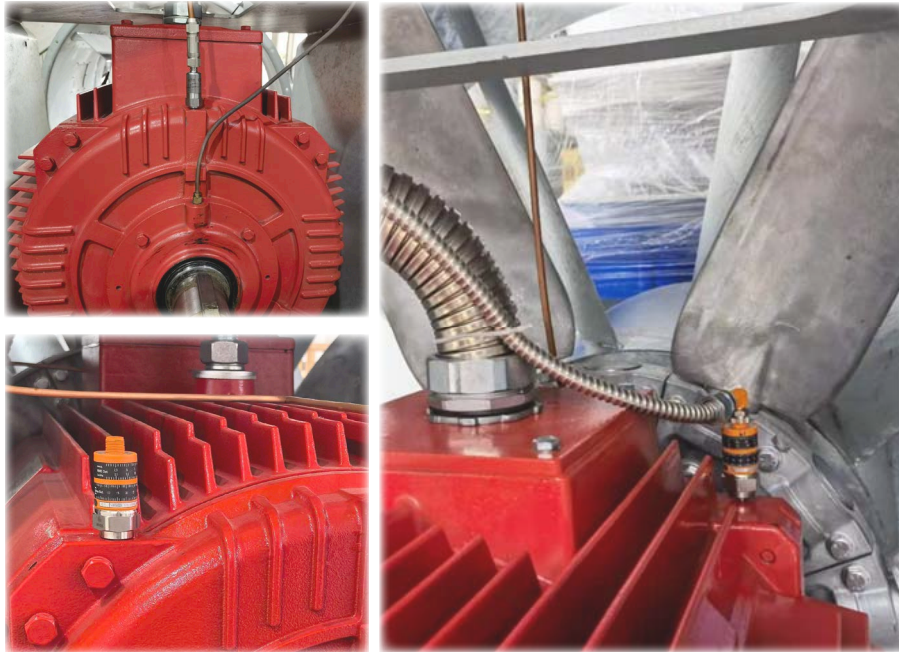

Note: Vibration Sensor should be installed at top of motor at drive end in vertical direction between -45 degree and +45 degree.

8.3 Bearings

8.3.1 Monitoring of bearings

Every bearing has to be checked regularly. Dirt particles, contaminants and moisture must not enter the bearing as they may cause premature failure. While re-lubricating or replacing bearings, utmost cleanliness must be observed. While monitoring bearings it is a great advantage to use electronic shock pulse measurement (e.g SPM-method). Measure should be made directly at the bearing unit. The special instructions of the test equipment manufacturer must be adhered to. Not only the momentary values but also the comparison of the data over a prolonged period is important since this best allows the changes in the bearing to become apparent. In rare cases SPM-measurements can lead to wrong interpretations. Bearing noise and temperature too should be recorded especially for machines that are critical. Increases in values are always a sign of danger.

The re-lubrication intervals are valid for stationary machines under normal conditions for non-ageing lithium soap lubricants, as long as the temperature on the external bearing ring remains below +70°C. For higher temperatures every increase by 15°C the greasing interval is halved. The maximum temperature limit of the grease is not to be exceeded.

The life expectancy of bearings is largely dependent on the operating conditions and the conditions at the site of installation. We strongly recommend regular bearing checks. The frequency depends on the importance of the fan. For machines of high importance we recommend annual bearing replacement even if the running time is very low and the run is satisfactory. Bearings for less important machines should be replaced less often or when a breakdown is imminent.

8.3.2 Additional instructions for various fan bearing types

The types of grease to be used and applicable re-lubricating intervals are specified in 8.3.3. Necessary re-lubrication should if possible be done while the machine is running with necessary safety precautions. If this is not possible, turn the shaft by hand. It is important that the inside of the bearings remain absolutely clean from moisture, dirt and dust. Bearings that located in the path of the airflow are provided with double-lip seals. High performance grease as mentioned in 8.3.3 must be used. At our factory all the bearings are lubricated with heavy-duty long life grease. The lubricant must be changed only after the long life of the lubricant has terminated.

Bearings with permanent lubrication

Bearings with permanent lubrication can be recognized by the absence of grease nipples and do not need re-greasing.

Pedestal block bearing with re-greasing device and grease control disc

During re-lubrication, control discs remove old grease and press it out through the openings into the bearing casing. During re-lubrication the temperature may temporarily rise due to excess grease. The temperature falls to its normal steady state level once the control disc ejects the excess grease. The re-lubrication is best done by taking the necessary precautions to avoid coming in contact with mobile parts-especially for a running machine, so that the surplus old grease that comes out can be immediately removed and not be carried away by the air stream (for fans in which the bearing lies in the path of the air stream, such as axial fans and centrifugal fans with double inlets).

Pedestal block bearing with re-greasing device and without grease control disc

Initially up to 2/3rd of the bearing is filled with grease. Re-lubrication of smaller quantities must be done at specified intervals. The correct quantity of grease should be applied, because over greasing may lead to an increase in temperature. The installed overpressure valve helps in compensating the pressure between the internal area and the atmosphere. After several re-lubrications if the casing is filled with grease, then the grease must be changed.

For this the upper part of the housing is taken off and the old grease is removed without damaging the bearing. New grease has to be squeezed by hand into the bearing. Please use clean grease and take care that no impurities come into the grease.

Pedestal block bearing with permanent lubrication and without grease nipple

For this the upper part of the housing is taken off and the old grease is removed without damaging the bearing. New grease is squeezed carefully by hand into the bearing. Please use clean grease and take care that no impurities come into the grease. The space between the lip seals too must be filled with grease so that the friction between the lips and shaft are reduced.

8.4 Functional description and mounting instruction for impellers and pulleys having taper lock bushes

Accessibility:

At first the impeller must be made accessible.

For axial fans the fan in general must be dismantled and placed on a level surface with the impeller pointing upwards. Exceptions are swing out type axial fans and fans inside jet cowls where the impeller is accessible after opening the door.

Functional description:

The hub has a conical inner bore. A conical bush that is cylindrical inside is inserted. While tightening the fixing screws, the bush is tightened and clamped between the shaft and hub.

Dismantling of impeller

- a) In case of corrosion rust solvent oil must be used. The use of hammers, crowbars or other objects of force must not be used!
- b) Detach all fixing screws. Depending on the size of the bush, unscrew one or two screws, oil them and screw them into the set bores.
- c) Tighten the screw(s) uniformly until the bush comes out of the hub so that the bush can move freely on the shaft.
- d) Remove the impeller with bush from the shaft.

Remounting of the impeller

- a) Clean and degrease all uncovered surfaces such as the bore and the conical surface of the taper lock bush as well as the conical bore of the hub. Insert the taper lock bush into the hub to coincide with all connection

bores (half-thread bores must always have half-plain bores on the opposite side).

- b) Mildly lubricate and screw in threaded stud (bush size 1008-3030) and/or cylindrical screws (bush size 3535 - 5050). Do not tighten the screws.
- c) Clean and grease the shaft. Push disc with taper lock bush onto the shaft till it sets into the desired position.
- d) While using a slot key place it first into the slot of the shaft. There must be a small play between the adjustment key and bore slot.
- e) Tighten thread studs and/or cylinder screws uniformly by using a screwdriver, DIN 911, with the torques provided in the table.
- f) After a short period of operation (1/2 to one hour) check torque of the screws and if necessary, correct it.

● Pull off Bore

○ Fixing bore with fixing screws

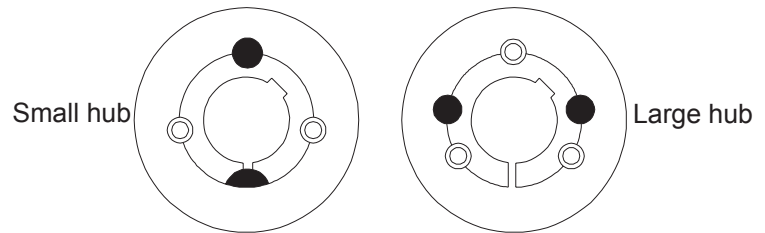

Bush	Starting torque of the screws [NM]	Fixing screws		Bush	Starting torque of the screws [NM]	Fixing screws		Bush	Starting torque of the screws [NM]	Fixing screws	
		No.	Size			No.	Size			No.	Size
1008 1108	5.6	2	1/4" BSW	2012	31	2	7/16" BSW	4040	170	3	5/8" BSW
1310 1315	20	2	3/8" BSW	2517	48	2	1/2" BSW	4545	192	3	3/4" BSW
1210 1215	20	2	3/8" BSW	3020 3030	90	2	5/8" BSW	5050	271	3	7/8" BSW
1610 1615	20	2	3/8" BSW	3535	112	3	1/2" BSW				

Table 1, Torque settings for taper hubs

Fan assembly

Carry out points 1 - 3 in reverse order. Then check the distance (measured under point 4), turn the impeller manually and check whether it turns freely.

8.5 Operation at higher temperatures (> 70 deg. C) / Smoke proof design F200 / F300 / F400 (EN 12101-3)

For fans designed for operation at higher temperatures, precautions against the touching of hot surfaces (e.g. safety guards, warning signs) must be taken. In case of cold starts, the power consumption could possibly exceed the design value and the current consumption could increase to inadmissibly high values. This is especially the case when centrifugal fans are not started against a closed flap. Careful observation of the start-up is required. The user has to secure that the cable that he inserts into the terminal box is suitable (attention if the fan unit is installed on AV mounts) and heat resistant. According to the temperature requirements, the wires inside the terminal box have to be isolated with additional glass fiber sleeve. The cable should not touch the fan casing and must be protected against mechanical damage.

Before the fan is switched off, it should be operated for some time at low gas temperatures (<100°C) until the impeller, shaft and housing have cooled down. This is to prevent heat from adversely affecting the bearings or grease at standstill. Also, the shaft shall be turned until it has cooled down, to prevent warping of the warm shaft.

The rules for correct distance away from flammable equipment must be respected at all times.



Attention: Check bearing grease in case of accidental interruption. It can liquefy or possibly leak out.

When using cooling discs for higher temperatures, it should be noted that adequate cooling is achieved only when the speed of rotation is sufficient. At higher impeller temperatures and low speeds (e.g. frequency converter) or when stopped (e.g. emergency stoppage or power failure), the user must cool the cooling disc externally, e.g. with a separate fan with a secured power supply.

8.6 ATEX - fans - general instructions, additional standards and instructions

The fan has a labeled earthing connection to which the operator must ground the fan with the entire system. To avoid danger of burning, no rust or rust film can form in the components with aluminum and no iron oxide-contained and light metal-contained paints can be used. Additional measures required by local and legal authorities, standards or edicts have to be followed. The specified distance between the rotating and stationary parts were maintained during the construction of fan. The fan must be stopped immediately when there are imbalance or abnormal fluctuations and the error must be rectified immediately. After dismantling and remounting of impeller, the distances must be checked.

As the manufacturer of fan, It must be pointed out that all relevant details about medium (components, concentration, temperature...), for operation (pressure difference, volume flow...) and for Ex-Zone are to be retained.

Instructions:

- For explosive environments, the operator must ensure that the used device category corresponds to the directive 94/9/CE of these Ex zones according to the directive 1999/92/CE.
- For fans for increasing the (earthing) gas pressure, we must refer to the "Guidelines for construction, maintenance and operation of gas compressors with an operating pressure up to 1 bar - G6" of Swiss Gas and Water Industry Association (SVGW).
- The installer/ system constructor/ operator is responsible for switches required, flaps, valves, flame blocks and detonation fuses for ensuring safety of the entire system in operation, and also during shut down and after shut down. During the construction of flame blocks and detonation fuses, special requirements are to be adhered to in accordance with EN 12874 §11.

General

- The danger zone due to flying parts in case of high pressure fans is basically in the radial direction.
- While setting up in an Ex-Zone, the fan must be suitable for this zone and must be labeled.
- In order to avoid and prevent the danger of burning, rust or rust film should not be present in fans and pipelines under any circumstances.
- Dust in the feed medium is permissible only if this is mentioned in the data sheet. The fan is fitted specially for this. There is danger of deposits in case of impermissible dust load. Thus, there can be imbalance leading to sparking. Dust clouds and deposits can get ignited.
- Undertake regular cleansing of components of adhering dust.
- Systems that are set up for operation with explosion-prone mixtures must have a grid with a max. mesh size of 12 x 12 mm at the inlet and outlet openings to keep the foreign particles away. A dust hood must be provided to protect against vertical falling in. The openings must be installed at a well-accessible and controllable site.
- The permissible feed medium and also the limiting values for temperature, if necessary, even the dust content and moisture, is to be fixed in the data sheet. Using fan for other media or outside the specified limit values is not as intended and not permissible.
- The fan is provided with corrosion protection as specified on the data sheets or a coat of paint. No iron oxide-contained and light metal-contained paints are used on fans for the ex-area even for subsequent coats. Ex-motors should not be given subsequent coats without written permission of manufacturer.
- The fan is provided with a labeled "Earth" connection to which it must be grounded with the entire system.
- The gap at the impeller inflow must be at least 2 mm. For diameters above 200 mm, the value of 1% of the largest possible contact diameter must be taken, but, a maximum of 20 mm. This is generally applicable even for shaft seal casings and safeguards.
- Inspections must be made to check whether it is maintained and is not reduced (e.g. due to bearing abrasion).
- If provided, sealing air and/or suction need to be connected to the shaft seal. Overpressure or under-pressure as well as through flow must be ensured during the operation.

- If available, automatic grease emitters are to be activated.
- Please take care of the provided gas-discharge. When there is too high or over discharge, it can lead to overload of engine and for too low or blocked discharge, it can lead to overheating of fan and dangerous high surface temperatures. If not specified otherwise, the volume flow must lie within -10% to +20% of the standard-volume flow.
- Exclusively, anti-static or electrically conducting driving belt must be used.
- The gas path of the fan must always be free so that the medium in the fan is not heated unnecessarily.
- After dismounting the fan, the remaining pipelines are to be closed. For dismantled fans, the operator needs to ensure that the deposits in the fan do not pose danger to humans and the environment. Clearance must be given by the operator in case of health-hazardous media.

Maintenance:

- In order to ensure proper operation of blower, a revision needs to be undertaken after 20000 hours of operation, latest after 36 months.
- In case the environmental temperature lies above 30°C over a longer period of time or the storage temperature exceeds 70°C, the above time periods must be reduced.

Temperature:

- The environmental temperature should not exceed 40°C.
- Fans in explosive environment must be designed and operated such that it is neither heated up unnecessarily due to inherent heating nor due to external heating at any place. The temperature class is fixed depending on the medium and the fan design in data sheet. The limit values according to EN 13463-1 are given subsequently:

Temperature class	Maximum permissible surface temperature
T1	450°C
T2	300°C
T3	200°C
T4	135°C
T5	100°C
T6	85°C

Table 2, Temperature class

- The gas temperature can increase above 70°C depending on the operating point, above all, at high pressures and small volumes. In this case, there is danger of combustion / injury in case one touches the surface. If the temperature is above 70°C during commissioning, trial runs or in later operation, the operator needs to undertake measures required for protection of people and things. (Warning signs, insulations).

8.7 Servicing

The rotor and housing are subjected to natural wear and tear through the action of dust, acidic and corrosive vapours, as well as gases which are mixed into the conveyed flow. The type and concentration of the dust, as well as the gases and vapours, can lead to deposits, abrasion and corrosion at the rotor and housing.

This natural wear and tear process can damage the materials till they can no longer fulfill the demands required of them. Unevenly distributed deposits on the rotor can lead to an imbalanced state and thus leading to noisy running and can subsequently result in damage to the motor bearings. Deposits in the housing can lead to a narrowing of the available cross-sectional area or the roughening of the housing panels and can cause an unfavourable effect on the fan's output data. Regular checks should be made depending on the conveyed media and other operating conditions, which differs on a case-by-case basis. The checks will reveal slight wear and tears, following which the individual parts can be cleaned in good time, or replaced if necessary.

Prior to all servicing work:

- Bring the fan to a halt in the prescribed manner and completely isolate the fan from the mains supply!
- Wait until the rotor has come to a halt!
- Ensure that the machine cannot be switched on again!
- Clean the fan
- Clean the suction apertures
- Clean the rotor (if necessary dismantle the protective anti-intrusion fitting)



Only use cleaning agents generally available through the trade and in compliance with the prescribed safety measures. Do not use scratching or scraping tools (protective surface coating will be ruined).

- Do not overload the motor!
- Do not bend the rotor or vanes!
- Assemble the protective anti-intrusion fitting.

General checks:

- Is there too much bearing play?
- Is the lubricant leaking from the bearings?
- Is the surface protective coating damaged?
- (Attention: Conveyed medium too aggressive!?)
- Are there any unusual noises during operation?
- Is the fan output still sufficient for possibly extended or shortened ducting system?

8.8 Overhaul

An exploded view of standard fans to facilitate dismantling - refitting. All the parts fitting together must be marked before being dismantled. Special attention must be paid to the allocation of parts. Parts that can be interchanged may cause difficulties in installation. The impeller can be installed and dismantled either by the use of an extraction disc or a clamping bush.

The bearings must not be canted. Shims that are already used must be re-used after alignment. The bearing casing and foundation must be carefully bolted. During the remounting of the impeller on the shaft, the use of graphite-based grease can be advantageous.

Caution: Taper-lock bushes should not be greased!

Axial fans with split casings must be differentiated from all other designs. The upper part can be lifted off. The impeller can then be detached either with an extraction disc or taper lock bush. The motor bolts can then be removed. Caution - Use lifting devices.

For undivided casing, the fan must be separated from other structural components such as nozzles, protection grills, silencers and ducts. If the impeller and the motor are to be removed then the fan must be placed with the vertical shaft on the floor. Next, the impeller can be detached either with an extraction disc or taper lock bush and the motor bolts removed.

Prior to all overhaul work:

- Bring the fan to a halt in the prescribed manner and completely isolate the fan from the mains supply!
- Wait for the rotor to come to a halt!
- Ensure that the machine cannot be switched on again!

Only use spare parts which have been tested and approved by us!

8.8.1 Dismantling the rotor

- Remove hub cover.
- Slacken off securing screw (Allen key), completely undo one grub screw and slacken off the tension cone using the forcing drilling.
- Pull off the rotor from the motor shaft (possibly using a puller tool).

8.8.2 Assembling the rotor

- Push the rotor onto the motor shaft
- Tighten both grub screws evenly, whilst observing the torque settings given in the adjacent table.
- Fit the hub cover

Screw	M4	M5	M6	M8	M10	M12	M16	M20
Torque setting	3.7	7.5	12	31	60	108	265	510
+0% / - 10%	NM	NM	NM	NM	NM	NM	NM	NM

Table 3, Torque settings for screws

8.8.3 Maintenance of anti-friction bearings

8.8.3.1 Fan bearing service interval / Frequency of re-lubrication:

The roller bearings of the standard AC motors are basically equipped with a permanently sealed lubrication system consisting of a high-quality, temperature-resistant, lithium-based roller bearing grease (melting point approximately 160°C). The amount of lubricant supplied to the bearing by the motor manufacturer is sufficient for 10,000 to 20,000 operating hours.

The life of grease varies greatly as a result of types of model, revolution speed, temperature, operational conditions etc. It is, therefore, impossible to be precise about replenishment intervals. However, for normal direct coupling transmission, the periods shown as Table 4 may be used as a guide.

Remarks:

- Please refer to the lubrication nameplate, if attached to the motor.
- For bearing numbers outside the range of Table 4, please contact Dongguan Wolter Chemco (Wolter Asia) at info@wolter.com.hk
- If the periods referred to in Table 4 for drive-end bearing and opposite drive-end are different, for the convenience of maintenance operation, please take the shorter one the required grease replenishment period of these bearings.

8.8.3.2 Kind of grease

a. Standard Class B & F motor

MULTEMP SRL, Shell ALVANIA R3 or Polyrex EM (polyurea base grease) will be used for all models with open bearings. Please check and follow lubrication nameplate for any special grease used in bearings. Please use identical grease or its equivalents when maintaining motor.

b. High temperature Class H motor

Mobil Polyrex EM, Exxon Polyrex EM (High temperature resistant compound lithium base grease) or DOW Corning 41 will be used for all models with open bearings. Please check and follow lubrication nameplate for any special grease used in bearings. Please use identical grease or its equivalents when maintaining motor.



Do not mix different kinds of grease.

Mixing grease with different type of thickeners may destroy its composition and physical properties. Even if the thickeners are of the same type, possible differences in the additive may cause detrimental effects.

8.8.3.3 Grease quantity

The amount of grease per replenishment depends on the type, size and construction of the bearings. The maximum amount of replenishment for each bearing is shown in Table 5.

8.8.3.4 Re-greasing



If re-lubrication is to be performed when the motor is running, stay clear of rotating parts.

It is advisable to re-grease when the motor is running to allow the new grease to be evenly distributed inside the bearing.

Before re-greasing, the inlet fitting should be thoroughly cleaned to prevent any accumulated dirt from being carried

into the bearing with the new grease. The outlet of grease drainage should be opened to allow the proper venting of old grease.

Use a grease gun to pump grease through grease nipple into the bearings. After re-greasing, operate the motor for 10-30 minutes to allow any excess grease to vent out.

Bearing Number		600 [1/min]	720 [1/min]	750 [1/min]	900 [1/min]	1000 [1/min]	1200 [1/min]	1500 [1/min]	1800 [1/min]	3000 [1/min]	3600 [1/min]
62XX	10										2000 Hrs
	12										
	13										
	14										1000 Hrs
	15										
	16										720 Hrs
	17										
	18	3000 Hrs									2000 Hrs
	20										
	22										1500 Hrs
	24										
	26										2000 Hrs
	28										
	30										1000 Hrs
32											
34										500 Hrs	
36											
38	2000 Hrs									1000 Hrs	

Table 4, Frequency of re-lubrication

Bearing Number	Amount of replenishment [g]
6210	30
6212	40
6213	50
6214	50
6215	60
6216	60
6217	80
6218	80
6220	100
6222	120
6224	120
6226	140
6228	160
6230	180
6232	200
6234	250
6236	300
6238	350
6240	400
6244	450
6248	500

Bearing Number	Amount of replenishment [g]
6310	40
6312	60
6313	80
6314	80
6315	100
6316	100
6317	120
6318	120
6320	160
6322	220
6324	270
6326	300
6328	400
6330	450
6332	500
6334	600
6336	700
6338	800
6340	900
6344	900
6348	900

Table 5, The maximum amount of replenishment

* Fill new grease until it overflows and the old grease is entirely replaced.

8.8.3.5 Oil re-lubrication (For oil lubrication types only)

Maintain proper lubrication by checking the oil level periodically and adding oil when necessary. Because of the initial clearing action of the bearing and the expansion of the oil as it comes up to operating temperature, the oil level will be higher after the motor has been in operation for a while than it is with the motor at standstill.

Overfilling should be avoided not only because of the possibility that expansion may force the oil over the oil sleeve and on to the rotor, but also because too high an operating oil level prevents the bearing from clearing itself of excess oil. The resultant churning can cause extra loss, high temperatures, and oxidized oil. If, during operation, the oil level goes above the maximum shown on the sight gauge, drain enough oil to bring the level back within the recommended operating range. **Do not permit the operating level to fall below the minimum shown on the gauge.**



Should it ever become necessary to add excessive amount of make-up oil, investigate immediately for oil leaks.

Change the oil at regular intervals. The time between oil changes depends upon the severity of operating conditions and, hence, must be determined by the motor user. Two or three changes a year is typical, but special conditions, such as high ambient temperature, may require more frequent changes. Avoid operating the motor with oxidized oil. Use only good grade, oxidation-corrosion-inhibited turbine oils produced by reputable oil companies.

8.8.4 Instructions on correct bearing replacement

Only allow work on the electric motor to be carried out by a craftsman or by a suitable motor winding workshop.

8.8.5 Electrical Motor and its connection

Electrical connection

All work must be carried out only by **qualified** technical personnel on the **idle** low voltage machine in visibly **activated** state **secured against restart**. This is applicable even for auxiliary circuits (for e.g. standstill heating). **Check whether the system is disconnected!**

Adhere to specifications on the rating plate as well as the wiring diagram in junction box. Exceeding the tolerances in EN 60034-1/DIN VDE 0530, Part 1 - Voltage $\pm 5\%$, Frequency $\pm 2\%$, and also unfavorable curve shape or missing symmetry - increases the heating and influences the electromagnetic tolerance. The connection must be undertaken such that a **permanent, secure** electrical connection is obtained (no dangling wire ends); use dedicated cable ends. Make **ground wire connection**.

The smallest air gaps between blank, live parts and against earthing should not be less than the following values: 8 mm for UN ≤ 550 V, 10 mm for UN ≤ 725 V, 14 mm for UN ≤ 1000 V. The junction box must be free from foreign bodies, dirt and humidity. Close cable glands that are not used and the box such that they are **dust-and water-proof**. Secure **half keys** for trial run without downthrust elements. **Check** the smooth functioning of brakes for low voltage machines with **brakes** before commissioning.

Operation

Vibration levels $V_{eff} \leq 3,5$ mm/s (PN ≤ 15 kW) or 4,5 mm/s (PN > 15 kW) are safe for normal operation. In some cases, higher values are to be expected, refer to ISO 14 694. In case of changes compared to the normal operation - for e.g. **increased temperatures, noises, vibrations** - the cause must be established, if necessary, referring to the manufacturer. Safety devices should not be disconnected even in trial operation. Switch off fan in **case of doubt**. Clean the air passages regularly if dirty. Regrease bearings with regreasing device when motor is **running**. Adhere to type of lubrication! In case the grease outlet bores are closed with stoppers (IP 54 Shaft side: IP 23 Shaft side and cooling side), **remove stoppers** before greasing and then close again thereafter. Bearings must be replaced in case of continuous lubrication (2Z-bearing) after about 10,000 hours (2 pole) or after 20,000 hours (higher-poled) or according to the specifications of the manufacturer.

Minimum speed / maximum speed

If a fan has been designed for speed-controlled operation, **the minimum speed** should not be less than **30% of the nominal speed**. If lower speeds are required for the system, special permission (= recalculation of drive motor/ checking the bearing) is required for the same.

Starting / Stopping / Reversing

Due to high moment of inertia of fan- impellers, a fan may be started, stopped or reversed maximum 4 times in an hour. At least a time span of 2 minutes must be maintained between two subsequent switching processes. If higher

switching cycles are required for the system, special permission (= recalculation of drive motor/ checking the drive motor) is required for the same.

Transport, storage

Damages found must be reported **immediately** to us. The commissioning may be delayed. Tighten the screwed transport bolts securely. They are designed according to the weight of the low voltage machine and do **not** apply additional loads. **Remove transport fastenings** before commissioning. Re-use for further transports. If low voltage machines are stored, ensure **dry, dust-free** and **vibration-free** environment ($V_{eff} \leq 0.2$ mm/s). Measure the insulation resistance before commissioning. Dry the winding for values $\leq 1k\Omega$ per Volt of measured voltage. Follow the "Storage instructions".

9 Tunnel Fans

9.1 Description

See the Chapter "2.2.1 JVT / RXJ"

9.2 Assembly

1. The type, number and size of anchor bolts depend on the quality of tunnel ceiling. If the pin is not given in our drawings, please ask the civil engineer.
2. The bore holes are to be marked on the tunnel ceiling using a template and drilled according to the instructions of the manufacturer (back cut, cleaning etc.).
3. Fasten the anchor bolts, undertake load test according to the manufacturer's specification (by load device / torque or the like).
4. Lift the jet fan and the suspending construction to the tunnel ceiling/ adjust all loose bolt connections.
5. Tighten all screw connections (refer to the following table for torques).
6. Check the alignment again and if need be, re-adjust the screw connections on the suspending construction.
7. Mount the anti-swing device (if available).
8. Install tear-off monitoring, adjust the electrical switch.
9. Mounting the catch rope/ chains on the tunnel ceiling with appropriate mounting angles, thimbles and rope grips (Details refer to drawing on the right). A slack of about 10 mm must be maintained.
10. Make all electrical connections
11. Inspect surface protection. If necessary, improve the paint supplied with fan.

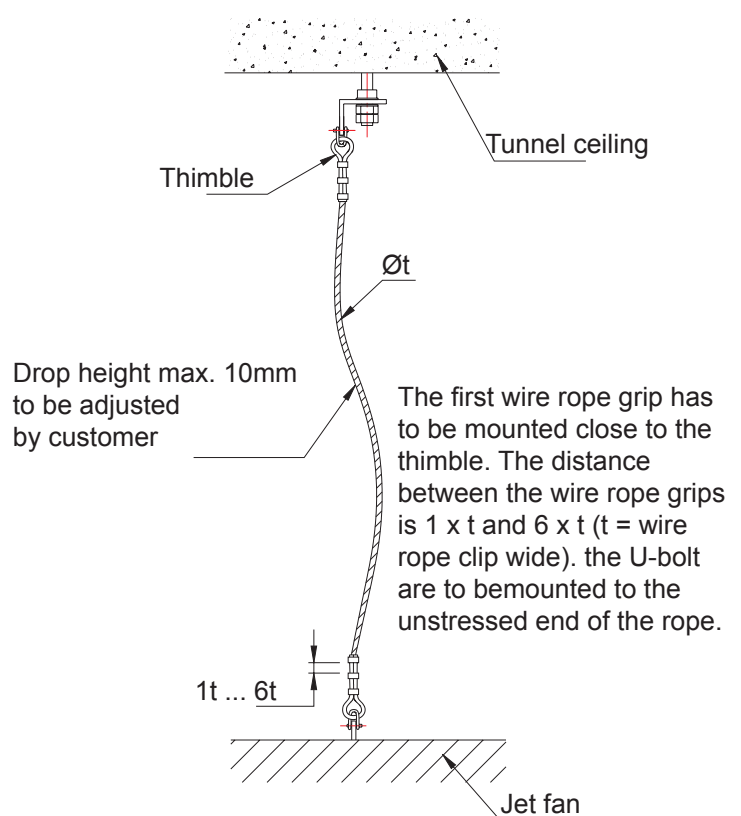

Rope - Ø t	Torque figure [Nm]	Units of wire rope grips
5	2	2
6,5	3,5	3
8	6	4
10	9	4
13	33	4
16	49	4

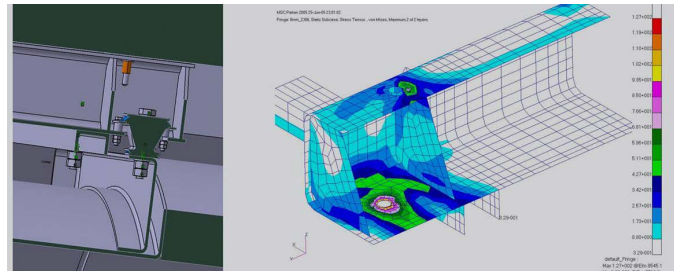
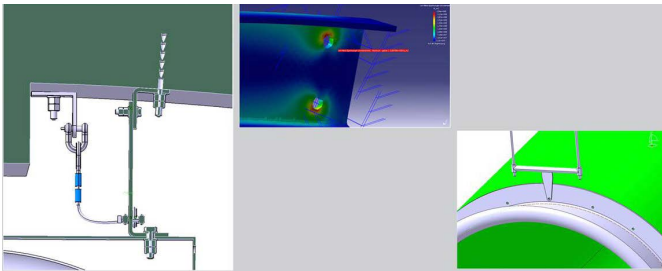
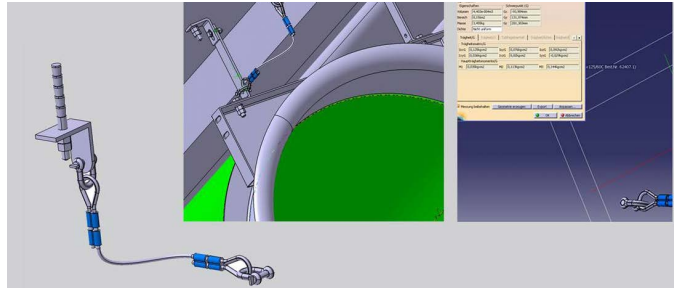
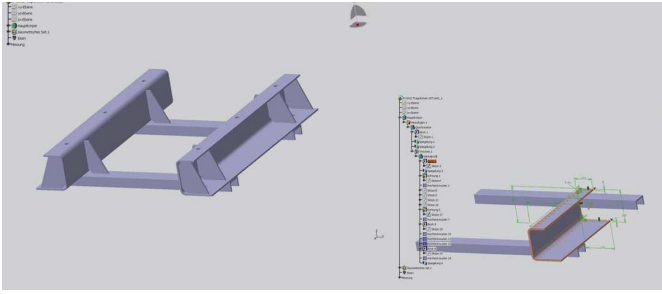

Torque figure in Nm (not binding value)											
Screws quality	8,8 (zink plated)	8,8 (hot dip galv)	A2/A4/A5 - 50 (turned)		A2/A4/A5 - 70 (rolled)		A2/A4/A5 - 8 (cold formed)		1.4529 (turned)		
friction coefficient	~ 0,14 (non greased)	~ 0,12 (greased)	~ 0,2 (non greased)	~ 0,1 MOS2-Paste (thread & head)	~ 0,2 (non greased)	~ 0,1 MOS2-Paste (thread&head)	~ 0,2 (non greased)	~ 0,1 MOS2-Paste (thread&head)	~ 0,2 (non greased)	~ 0,1 MOS2-Paste (thread&head)	
Wind size	M4	3,3	2,4	1,3	0,8	2,6	1,7	3,5	2,3	1,7	1,1
	M5	6,5	4,6	2,4	1,6	5,1	3,4	6,9	4,6	3,4	2,3
	M6	11,3	8,1	4,1	2,8	8,8	5,9	11,8	8	6,0	4,0
	M8	27,3	20	10,1	6,8	21,4	14,5	28,7	19,3	14,4	9,5
	M10	54	39	20,3	13,7	44	30	58	39,4	28,5	18,9
	M12	93	66	34,8	23,6	74	50	100	67	49	32,5
	M14	148	106	56	37,1	119	79	159	106	78	52
	M16	230	164	86	56	183	121	245	161	121	80
	M18	329	235	122	81	260	174	346	232	173	115
	M20	465	332	173	114	370	224	494	325	245	162
	M22	634	453	227	148	488	318	650	424	334	221
	M24	798	570	284	187	608	400	810	534	421	279
	M27	1176	841	-	-	-	-	-	-	-	-
	M30	1597	1142	-	-	-	-	-	-	-	-
	M33	2161	1545	-	-	-	-	-	-	-	-
M36	2778	1986	-	-	-	-	-	-	-	-	
M39	3597	2572	-	-	-	-	-	-	-	-	

Table 6, Attention: Subsequent control just with 80 % of the above-mentioned values

9.3 Common mounting errors

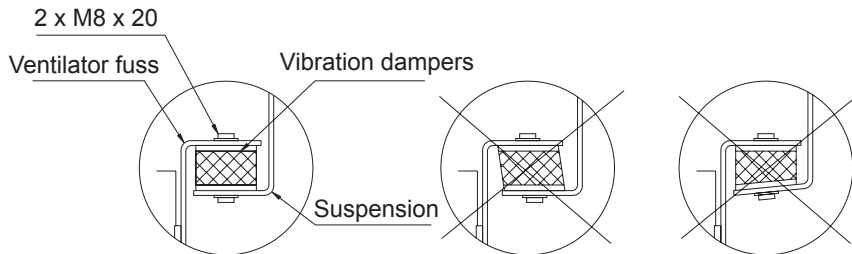

9.4 Nameplate

All jet fans have a name plate near the terminal box stating all important information such as the rated power of the electrical drive motor and also the rated current that enables the electrician to connect the jet fan to the switchboard with these two parameters.

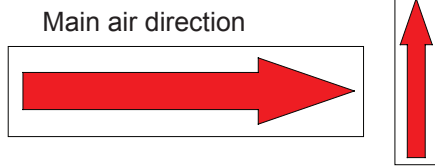

Wolter GmbH & Co. KG Am Wasen 11 D-76316 Malsch Germany Tel: +49 (072 04) / 9201-0 Fax: +49 (072 04) / 9201-11					
CE		Date: / / DD/MM/YY			
Model: _____		S/N: _____			
Volume: _____	c.m.s.	Pressure: _____	Total / Static		
Power: _____	Volt / Ph / hz	Thrust: _____	N	OV: _____	
Speed: _____	r.p.m.	Motor: _____	Kw	IP: _____	
Angle: _____	Degrees	Temp: _____	j°C/hr	Cl: _____	Insl.
Form: _____	running	FLC: _____	amps.	Wt: _____	Kg
Quality Assurance and certified - ISO 9001:2000. Conformity with DIN24 163 and ISO5801, Pt. 1 Cat D					

All jet fans have a main airflow direction. The power consumption as well as the sound pressure level is lower in this blow direction than in the reverse direction. This main airflow direction is marked with a big arrow for correct mounting in tunnel. For reversible jet fans, the reverse airflow direction is marked with a smaller arrow.

9.5 Operation: Starting, stopping/ reversal

START Jet fans have a run-up time of less than 10 seconds depending on the type, size, background speed and voltage drop during the start phase. After this time period, the jet fan must reach its rated speed - if this is not the case, it must be switched off and the reason for the longer run-up time must be determined.

STOP/REVERSAL Here, we have to distinguish between normal case and in case of fire: In normal case, a time period of at least 2 minutes must exist between the switching off and renewed starting in the opposite direction (allowed only for reversible jet fans!). Only in an emergency situation (in case of fire), it must be started after 20 seconds again in the opposite direction.

9.6 Operational safety

(In addition to the already mentioned General instructions, the following instructions are applicable)

NECESSARY SAFETY CHECKS (latest every 6 months, more often at the initial stage)

Since the fans operate close to people and can be easily damaged, they must be inspected for external damages at least every 6 months and more often at the initial stage. All damaged parts must be exchanged immediately. The vibration level is to be inspected according to VDI 2056 / ISO 2372 in horizontal radial, horizontal axial and vertical radial direction at measuring points that are marked during first measurement. By comparing the measured values over a longer period of time, changes can be observed. If the values change distinctly, the causes must be investigated, for e.g. dirt on the impeller. If necessary, cleaning and rebalancing must be undertaken. Increased vibration values can lead to destruction of the fan, they represent grave risks to people and exclude warranty from our side. Vibrations can lead to loosening of the ceiling fastening. In cases where dirt is present and can lead to greater danger, inspection and cleaning must be undertaken more regularly and vigorously (especially for fans/ Vibration dampers made of stainless steel, must be freed from all deposits of corroded particles from the surface). The maintenance cycle has to be adapted to suit the local situation (humidity, pollutants etc.) and may need to be increased.

9.7 Recommended safety checks

VISUAL INSPECTION (At least every six months, more often at the initial stage)

Proper inspection for damage and corrosion of silencers, impeller, inlet cone, motor, cable, connections, suspension and vibration dampers. Damages, especially damages to the surface protection, must be eliminated, before the damage becomes worse.

NOISE CHECK (every 6 months, more often at the initial stage)

The smooth functioning can be ascertained by checking noise and heating. The noises generated at the start and while stopping can be compared with those of similar fans.

INSPECTION OF MOUNTING (Every 6 months, more often at the initial stage)

Careful inspection of all bearing parts and screw connections. All nuts must be secured against loosening and fixed with correct torque. Damaged surface protection at the screw connections should be rectified.

10 Commissioning checklist

Name of Project / Machine Number:	FAN TYPE		Maintenance No.	
	AXIAL	JET	EXAMINER	DATE
JOB STEPS				
First inspection				
- Inspection of transport damages	X	X		
- Inspection of completeness	X	X		
Inspection after mounting				
- flexible connection not damaged	X			
- Vibration damper correctly adjusted	X	X		
- Secure erection guaranteed	X			
- Secure suspension guaranteed		X		
- All screws connections on the suspension construction tightened with correct torque		X		
- Catch ropes/ securing chains mounted correctly with slack of < 10mm		X		
- All damages to paint rectified	X	X		
- All basic safety instructions considered	X	X		
Inspection during commissioning				
- All basic safety instructions considered	X	X		
- Functioning of bearing status analysis checked	X	X		
- Functioning of fluctuation monitoring checked	X	X		
- Functioning of tear-off monitoring checked		X		
- Direction of rotation checked	X	X		
- Vibration values of bearing or motor measured. Max. between 4,5 to 7,1 mm/s horizontal / vertical / axial acc. to ISO 14694/ ISO 10816-3mm/s mm/s mm/s	X	X		
- Sound pressure level measured (1 - 3m / 45° removed from suction)dB(A)	X	X		
- Operation on frequency converter (yes / no / TYPE of FC)	X	X		
- Electrical values measured Voltage / FrequencyV / Hz Current Phase U / V / W A / A / A	X	X		

Commissioning checklist



Name of Project / Machine Number:	FAN TYPE		Maintenance No.	
			EXAMINER	DATE
WORKING STEPS	AXIAL	JET		
Maintenance (at least every 6 months)				
- Bearing status checked/ re-greased	X	X		
- Flexible connections checked for leakage	X			
- Vane controller- movement of blades checked	X			
- Vibration values of motor B-bearing measured horizontal / vertical / axialmm/s mm/s mm/s	X	X		
- Vibration values of casing measured horizontal / vertical / axialmm/s mm/s mm/s < = 4,5 mm/s : good > = 9,0 mm/s : caution > = 12,5 mm/s : switch off	X	X		
- Sound pressure level measured (3 m / 45° removed from suction)dB(A)	X	X		
- Electrical values measured voltage / Frequency.....V / Hz Current Phase U / V / W A / A / A		X		
- Visual check for corrosion (possible rectification of paint damages) - Blower - Vibration damper - Impeller	X	X		
- Visual check for corrosion - Motor	X	X		
damages checked - Blower - Vibration damper - Impeller	X	X		
- Check all screw connections of suspension construction		X		
- Check catch device/ catch rope		X		
- Insulation measurement at wrm motor (Resistance winding –mass with 500 V DC voltage) MegaOhm	X	X		
- In case stainless steel-blower / -silencer -> All deposits of corroded particles on the surface removed	X	X		
- Functioning of fluctuation observation checked Read-off values horizontal / vertical / axial mm/smm/smm/s	X	X		
E-Kit of tear-off –safety checked				

11 Instructions regarding special types of dangers

11.1 Electrical energy

Use only original fuses with specified current rating! Switch off the machine/plant immediately in case of interruptions in the electrical power supply!

Work on electrical devices or equipment must be undertaken only by a skilled electrician or by instructed personnel under the supervision of a skilled electrician in accordance with the electro-technical rules.

Machine parts must be disconnected if inspection, maintenance and repairs must be undertaken– if prescribed. The de-energized parts must be inspected first for disconnection, then, ground them and short-circuit them and also insulate live parts!

Inspect/ check electrical equipment of machine regularly. Defects such as loose connections or scorched cables, must be rectified immediately.

If work is required on live parts, a second person who can activate the emergency-off- or main switch in case of emergency needs to be around and involved. Secure work area with a red-white safety chain and warning sign. Use only insulated tools!

Connect the feeder cable to the ground while working on high voltage components after cutting off voltage and short-circuit the components, for e.g. capacitors with a grounding rod!

Tightening torque for electrical terminal boards (values) in Nm:		
bolts		starting torque in Nm
thread <i>d</i>	material	
M4	CuZn37 F45	1,2
M5		2
M6		3
M8		6
M10		10
M12		15,5
M16	CuZn37 F38	30
M20		52
M10	E - Cu57 F25 oder E - Cu58 F25	10
M12		15,5
M16		30
M20		52
M24 x 2		80
M30 x 2		150
M33 x 2		197
M36 x 2	252	

Table 7 Tightening torque for electrical terminal boards

11.2 Gas, dust, steam, smoke

Welding, frame cutting and grinding work on the machine can be undertaken only if permission has been given explicitly.

There is risk of fire and explosion!

Before welding, frame cutting and grinding, the machine and its surroundings must be cleaned, free from dust and combustible material and ensure sufficient ventilation (Risk of explosion)!

Observe all national regulations if work have to be carried out in narrow rooms!

11.3 Hydraulics, pneumatics

Only trained personnel with special knowledge and relevant experience in hydraulics must undertake work on hydraulic equipment!

All pipes, ducts and connections have to be inspected regularly for leakage and obvious damages! Rectify damages immediately! Splashed oil can lead to injury and fires.

Depressurize all system sections to be opened and pressurized pipes (hydraulic, compressed air) before beginning repair work according to the descriptions of components!

Lay hydraulic and compressed air pipelines properly before mounting them! Do not interchange connections! Armature, length and quality of pipelines must comply with the requirements.

11.4 Noise

All sound-protecting devices on the machine must be in closed position during the operation.

Wear prescribed ear protection!

11.5 Oils, grease and other chemical substances

When handling oil, grease and other chemical substances, adhere to the safety instructions applicable for the product!

Caution while handling hot equipment and auxiliary material (risk of burning or scalding)!

11.6 Portable machines (Machines used at different locations)

Use only hoists and load suspending devices with sufficient lifting capacity during loading work!

Appoint an expert for the hoisting work!

Lift machines properly with hoists only in accordance with the specifications of operating instruction manual (fixing point for load suspending devices etc.)!

Use only suitable transport vehicle with sufficient lifting capacity!

Ensure reliable loading. Use suitable fixing points!

Equip machine with recommended/supplied devices against unintentional change in position before or directly at the end of loading work! Put up appropriate warning sign!

Properly remove devices before re-commissioning!

Carefully re-mount the parts that were dismantled for transport purposes before re-commissioning and fix them!

Disconnect the machine or plant from any external energy supply even for minor changes in location! Connect the machine properly to the mains again before re-commissioning!

Proceed in accordance with the operating instruction before re-commissioning!



Reference: Operating Instruction **MT01**, V2024/September, Printed in September, 2024

Wolter Asia Ltd.

Unit A4, 3rd floor, Merit Industrial Centre, No.94 To Kwa Wan Road, Kowloon, Hong Kong
Tel. +(852) 2456 0198; Fax +(852) 2456 0290; www.wolter.com.hk; info@wolter.com.hk

Guangdong Wolter Chemco Ventilation Ltd.

Jigongkeng Administrative Zone, Futian, Boluo, Huizhou, Guangdong, P.R.China
www.wolter.com.hk; info@wolter.com.hk

Dongguan Wolter Chemco Ventilation Ltd.

No.69, Miao Bian Wang Road, Shipai, Dongguan, Guangdong, P.R.China
Tel. +(86) 0769 8655 7298; Fax +(86) 0769 8655 7278