

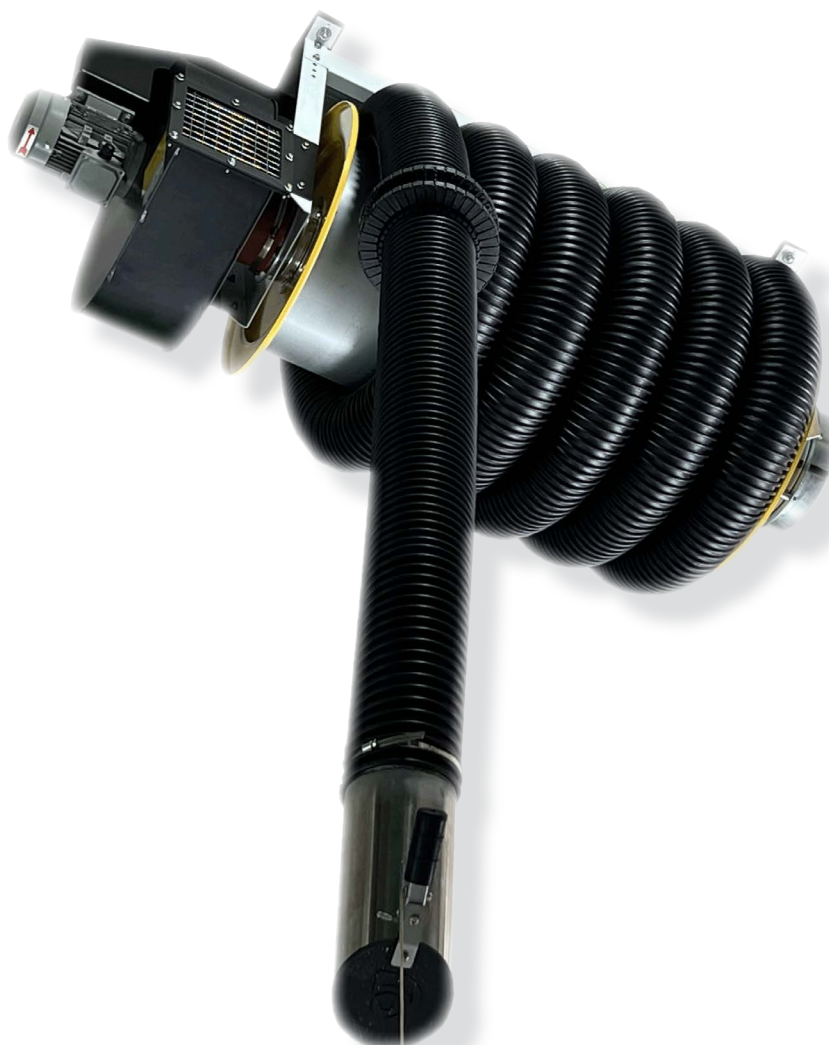

Operation and Maintenance Manual

Wolter Vehicle Exhaust Hose Reel (VHS) with Exhaust (VE / VD) Fan Unit





Contents

- 1 General safety notes 3
 - 1.1 The operator's duty of care 3
 - 1.2 Explanation of the safety symbols used 3
 - 1.3 Basic safety measures 4
 - 1.4 Particular kinds of hazards 4
- 2 Product description 5
 - 2.1 General 5
 - 2.2 User manual 5
 - 2.3 User..... 6
 - 2.4 Installation 5
 - 2.5 Use..... 5
 - 2.6 Operating the system 6
 - 2.7 Service, maintenance and repairs 6
- 3 Product description 6
 - 3.1 Stipulated usage 6
 - 3.2 Service and technical support 6
 - 3.3 3.3 Identification of the product 7
 - 3.4 Reel (VHS) Technical data 7
 - 3.5 Exhaust Fan VE/VD Technical data 10
- 4 Transportation and Storage 13
 - 4.1 Transportation 13
 - 4.2 Storage 13
- 5 EC Declaration of Conformity 14
- 6 VHS Commissioning and Parts Replacement 15
 - 6.1 Hose Reel Commissioning (assembly and retracting tension setting) 15
 - 6.2 Mounting Installation Height and dimensions 17
 - 6.2.1 Mounting Installation 17
 - 6.2.2 Reach and mounting height 18
 - 6.3 Operation 18
 - 6.4 Mounting options 18
 - 6.4.1 Direct mouth fan 18
 - 6.4.2 Micro switch 19
 - 6.5 Maintenance 19
 - 6.5.1 Replacing the exhaust hose 19
 - 6.5.2 Replacing the spring module 21
 - 6.5.3 Replacing bearings 21
 - 6.5.3.1 Replacing the Drive Bearing with Collar on the Drive Plate 21
 - 6.5.3.2 To replacing the hose Bearing with Collar on the fan plate 23
- 7 Exhaust Fan VE / VD Installation 25
- 8 Fan Initial Start-up 25
 - 8.1 Checks prior to initial start-up 25
 - 8.2 Starting up the fan for the first time 26
 - 8.3 Checks after initial start-up 26
- 9 Trouble Shooting 26
 - 9.1 Fan Help with Malfunctions 26
 - 9.2 Tabular overview of possible malfunctions and aids in eliminating those malfunctions 26
- 10 General Maintenance 27
 - 10.1 VE / VD Servicing..... 27
 - 10.2 Prior to all servicing work 27
 - 10.3 Recommended periodic inspection intervals 28
 - 10.4 Periodic inspection checks 28
 - 10.5 VE / VD Maintenance Schedule MC001 29
- 11 The Unit Pressure Loss Calculation 30
- 12 Spare Parts 31

Introduction

This publication is for use on standard VHS with VE/VD fan and all information are subjected to changes or amendment with or without notification.

It is the users responsibility to ensure this documents are most updated and it is only serve as a guideline for installation, use, maintenance and repair work.

Always consult the manufacturer, if necessary and thus the manufacturer cannot be held responsible for any damage resulting of this publication or either for any errors occurring in this publication. All rights reserved.

1 General safety notes

1.1 The operator's duty of care

The Wolter Vehicle Exhaust Hose Reel (VHS) with VE/VD fan term as "Unit" in this publication have been constructed and built whilst taking into account an analysis of the hazards involved, and after careful selection of the harmonised standards to be observed, as well as other further technical specifications. They thus correspond to the current level of technology and guarantee a high degree of safety. In operational practice, however, this level of safety can only then be attained if all required measures are taken. It is incumbent upon the operator's duty of care to plan these measures and to monitor their execution.

Users are required to familiarize themselves with installation and wiring instructions in addition to requirements of all applicable codes, laws and standards.

The examples and diagrams in this manual are included solely for illustrative purposes.

Because of the many variables and requirements associated with any particulate installation, Wolter cannot assume responsibility or liability for actual use based on the examples and diagrams.

No patent liability is assumed by Wolter with respect to use of information, circuits, equipment, or software that may be described in this manual. Throughout this manual, when necessary, notes may be used to make you aware of safety considerations.

Fume exhaust exposure levels should be checked upon installation and periodically thereafter to ensure that they fall within applicable regulations and exposure limit values.

In particular, the operator must ensure that

- › the Unit is only used as stipulated on "Product Description"
- › the Unit is only operated in a faultless and functional condition and that safety fittings, especially, are regularly examined with respect to their functionality
- › the operating instructions are always maintained in a readable condition and are available at the Unit's location of deployment in their entirety
- › only sufficiently qualified and authorised personnel operate, maintain and repair the machine
- › these members of personnel are familiar with the operating instructions and especially the safety notes contained therein
- › no safety and warning signs fitted to the fan are removed, and that they are kept in a readable condition.
- › the Unit's surrounding is kept clean to avoid items from being sucked into the fan and/or blocking the air flow

1.2 Explanation of the safety symbols used

The following symbols are used in these operating instructions. These symbols are, above all, intended to draw the reader's attention to the text contained in the adjacent safety note.













Warning

This symbol indicates that dangers exist which are hazardous to life and health.



Warning

Identifies information about practices or circumstances that can cause an explosion in a hazardous environment, which may lead to personal injury, death, property damage, or economic loss.



	Warning	Procedures which, if not carried out with the necessary caution, may damage the product or cause serious personal injury.
	Warning	Fire hazard! Important warning to prevent fire.
	Attention	Identifies information about practices or circumstances that can cause an explosion in a hazardous environment, which may lead to personal injury, death, property damage, or economic loss.
	Attention	A remark with additional information for the user. A remark brings possible problems to the user's attention.
	Caution	Procedures, if not carried out with the necessary caution, could damage the product, the workshop or the environment.
	Mortal danger	Electrical hazard. Serious - and also fatal - injury can result if these notes are disregarded.
	Shock hazard	Labels may be on outside or inside of fans and control boxes used in the exhaust removal system, to alert people that dangerous voltage may be present.
	ARC flash hazard	Labels may be on outside or inside of the equipment, for example control box, to alert people to potential Arc Flash. Arc Flash will cause severe injury or death. Wear proper Personal Protection Equipment (PPE). Follow ALL regulatory requirements for safe work practices and for Personal Protective Equipment (PPE)
	Tip	Suggestions and recommendations to simplify carrying out tasks and actions.
	Note	Indicates user tips and other useful advice.

1.3 Basic safety measures

Wolter VHS and VE/VD fans are, at the moment of delivery, manufactured to the current level of technology. Extensive materials, function and quality checks assure them of a high level of usefulness and long service life. Nevertheless, these machines can be dangerous if they are improperly used by untrained personnel or are used in a non-stipulated manner.

 Read these operating instructions carefully before putting the unit into operation!

Only operate the unit in its enclosed state with properly fitted built-in protective screens.

-  - Assembly, electrical connection and maintenance may only be carried out by trained craftsmen!
-  - Only operate the unit in the manner stipulated and within the specified output limits (see rating plate) and with approved conveyed media!

1.4 Particular kinds of hazards

The VE/VD centrifugal fans in this respect, particular hazards are caused by the impeller rotor and through the flow of air, which can, at times, be considerable. For this reason the following points are to be observed:

- ▶ Never reach into the rotor when it is rotating. Do not try to use your hand as a brake for the rotor during maintenance work.
- ▶ Loose clothing or light parts can be sucked in by the draught of air. That is why you should always wear tight-fitting clothing during maintenance work and whilst near the fan inlet.

- › Larger items can obstruct or totally ruin the rotor and other parts of the fan. For this reason, the protective screens and built-in guide vanes on the fan inlet and outlet must be fitted at all times during operation.
- › The rotor must not be put into operation while it is removed from the housing

2 Safety

2.1 General

The manufacturer does not accept any liability for damage to the product or personal injury caused by ignoring the safety instructions in this manual, or by negligence during installation, use, maintenance, and repair of the product mentioned on the cover of this document and any corresponding accessories. Specific working conditions or used accessories may require additional safety instructions. Immediately contact your supplier if you detect a potential danger when using the product.



Note

The user of the product is always fully responsible for observing the local safety instructions and regulations

2.2 User manual

- › Everyone working on or with the product must be familiar with the contents of this manual and must strictly observe the instructions therein. The management should instruct the personnel in accordance with the manual and observe all instructions and directions given.
- › Always keep the manual with the Unit.

2.3 User

The use of this product is exclusively reserved to authorized, trained and qualified users. Temporary personnel and personnel in training can only use the product under supervision and responsibility of skilled engineers.

2.4 Installation

- › Inspect the unit and check it for damage. Verify the functioning of the safety features.
- › Never install the Unit in front of entrances and exits which must be used for emergency services.
- › Make sure that the workshop, in the vicinity of the product, contains sufficient approved fire extinguishers

2.5 Use

- › Check the working environment. Do not allow unauthorized persons to enter the working environment.
- › Use common sense. Stay alert and keep your attention to your work. Do not use the Unit when you are under the influence of drugs, alcohol or medicine.
- › Make sure the room is always sufficiently ventilated; this applies especially to confined spaces

2.6 Operating the system

- With the VHS, an operator pulls the hose down Fig.1, which releases the locking plate (15) and can lock at a require position;

When the hose (37) is no longer needed, the operator pulls down on the hose to release the locking plate (15) and should guides the hose (37) back to its rest position, which is determined by the hose stopper Fig.2.

Fig.1: 1 = pull the hose down

Fig.2: 1 = pull down to release the locking plate
2 = guide the hose back

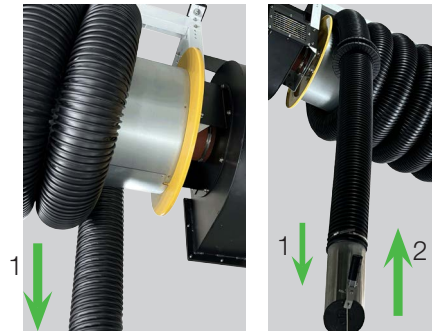

Fig.1

Fig.2

2.7 Service, maintenance and repairs

- This manual contains instructions for replacing the hose (37), replacing the spring module (07) and replacing Drive bearing (09) and Hose Bearing (16) with collar. (Refer to the Parts Replacement Section 6.6 for details replacement.).

3 Product description

3.1 Stipulated usage

Our Vehicle Exhaust Unit's have been specially developed for use in modern garages, car parks, warehouses and workshop etc to removes pollution gas and fumes aiming to improve airflow and overall comfort and can prevents the extraction hoses from entangling, thus increase works safety and tidiness. The Unit can be ceiling or on a wall mounted and best used in a stationed workshops with very limited space.



Fig.3

The VHS of single or double heavy-duty springs module (07) as Fig.3 can be factory installed to drive hoses of different length and weight requirement. An operator pulls the hose (37) down to a convenient position, which locks the hose (37) in place; when no longer needed, the operator recoils the hose (37) by pulling down on the hose, allowing the hose (37) to recoil in a controlled manner. The VHS can be used in central systems or with direct mounted. It is designed to operate with hose (37) diameters of 100, 125, 150 and 200 mm.

Note: Direct Mount fans are NOT available for the 200 mm version!

3.2 Service and Technical support

Unit description

The maximum hose length the Unit is dependent on these factors:

- the specific version of VHS reel ordered;
- the type and size of the hose;
- the exhaust fan;
- the nozzle

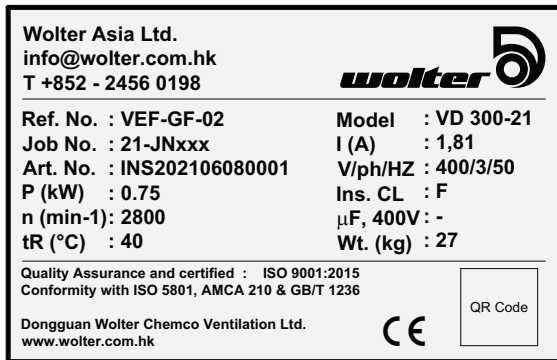

Fig.4



Fig.5

3.3 Identification of the product

The identification plate contains:

- › the fan model (eg. VD 300-21) & reel model (VHS 850-150)
- › the Art No.

3.4 Reel (VHS) Technical data

VHS come with a high-quality sealed coil spring module (07) (An additional module can be factory installed to increase lifting capacity). The spring module (07) is located outside of the VHS for easy replacement, if needed. The VHS maximum lifting capacity is 18 kg with a single spring module (07) and 34 kg with double spring modules (07).

Note: Optional double spring module (07) are available for Model 850, 1050 and 1050-200 models with hoses weight over 18Kg.



Fig.6

- I. Reel casing (03) Fig.6 provides a secure and space-friendly storage location for the hose (37):
 - Smooth, zinc-plated case on which the hose rolls;
 - Reel side plates are powder-coated with yellow;

- II. The Base Frame (08) Fig. 7 are of powder-coated steel provides support and strength for longevity and robustness.

- III. The Fan Plate (12) Fig. 7 and Drive Plate (01) are of powder-coated steel.

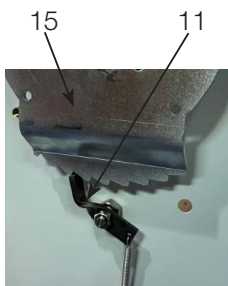

Fig.8

- IV. Locking Plate (15) Fig. 8 that lock and holds the hose in the required position.

The hose (37) aFig. 10 is released at the next pull. The Toggle leg (11) Fig. 8 made of harden steel c/w a high quality spring coil (06)

- V. Standard Nozzle (43) Fig. 9 with hose clip (40).

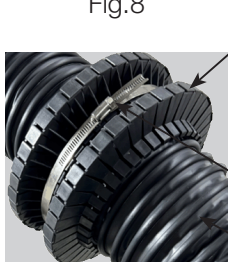

Fig.10

- VI. a Hose Stopper (20), hose clip (40) are included so that the hose stopper (20) can be rest at an adequate height on return



Fig.7



Fig.9



VII. Spring Module (07) Fig. 11 suitable for 18 kg weight, which is enclosed in a metal spun casing. (An additional module (07) can be factory installed to increase lifting capacity).

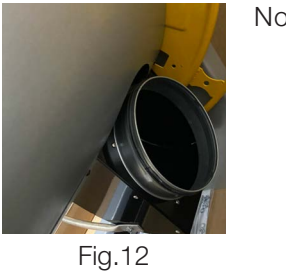

Note: The 200 mm hose come with a 200 mm duct connection fitting Fig.12



E.g. Unit model VD 320-30 with VHS 1050-150

Fig.13

VHS Dimensions

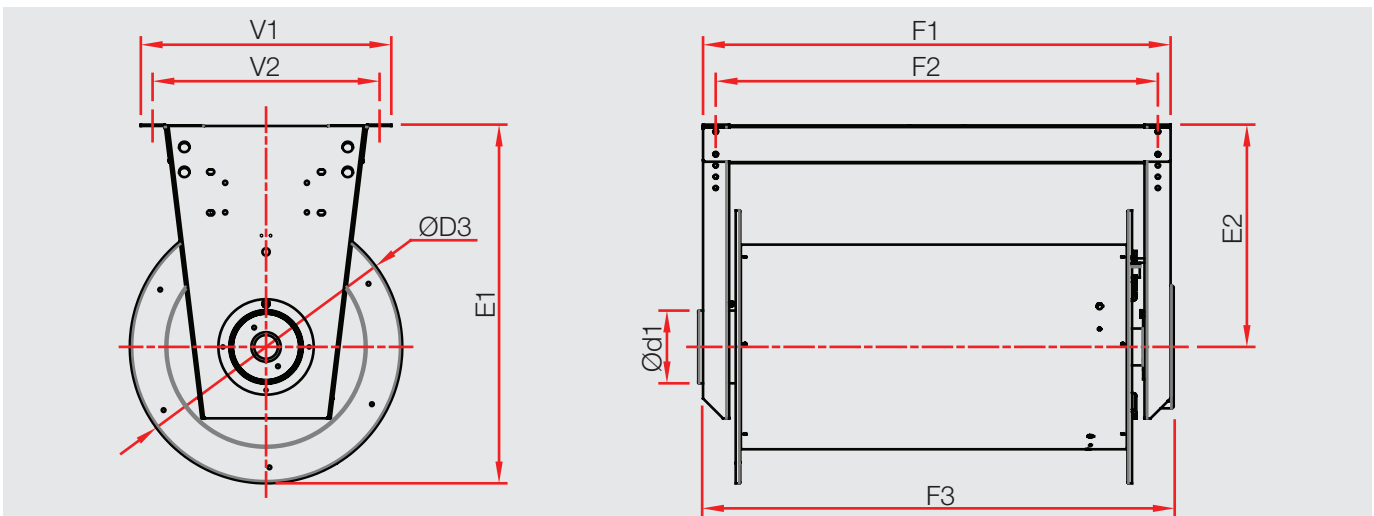

Table 1

Model	d1	D3	E1	E2	F1	F2	*F3	V1	V2
-	[mm]	[mm]	[mm]	[mm]	[mm]	[mm]	[mm]	[mm]	[mm]
VHS 450	160	600	789	489	630	574	650	552	500
VHS 650	160	600	789	489	830	774	870	552	500
VHS 850	160	600	789	489	1050	974	1050	552	500
VHS 1050	160	600	789	489	1230	1174	1270	552	500
VHS 1050-200	200	760	966	589	1430	1374	1295	578	525

Note: 1, *If a second spring cassette is added to the VHS 850 or 1050 reel, add 62 mm.

2, VHS 100-150 mm hose models include a 150 duct connection reducer.

3, Subject to change without prior notice.

Weight of VHS unit without components

Table 2

Product Name	Hose Diameter	Max. hose length on reel	📦 (w/o components)
[-]	[mm]	[m]	[kg]
VHS 450-100	100	6	59
VHS 650-100	100	10	66
VHS 650-125	125	7.5	66
VHS 850-100	100	10	72
VHS 850-125	125	11	72
VHS 850-150	150	10	72
VHS 1050-100	100	12.5	75
VHS 1050-125	125	12.5	75
VHS 1050-150	150	12.5	75
VHS 1050-200	200	10	75

Note: 1, If a second spring cassette is included, add 8.6 kg to the product weight.
 2, Subject to change without prior notice.

Example of total hose and component weight

A 150 mm standard hose can be connected and circle the reel casing for a max of 5 rotations which is equal 8.2 m. Example of total weight required as below:

Table 3

Product Name	📦 (Calculation)	📦 (Total)
EH 150 Hose	1.04 kg/m	8.53 kg
MN 150 Nozzle	3.50 kg	3.50 kg
Hose Stopper	0.80 kg	0.80 kg

Total weight of hose and components: 12.83 kg.
 VHS lifting capacity (single module): 18.00 kg.

3.5 Exhaust Fan VE/VD Technical data

Fan type code

V D 320 - 30

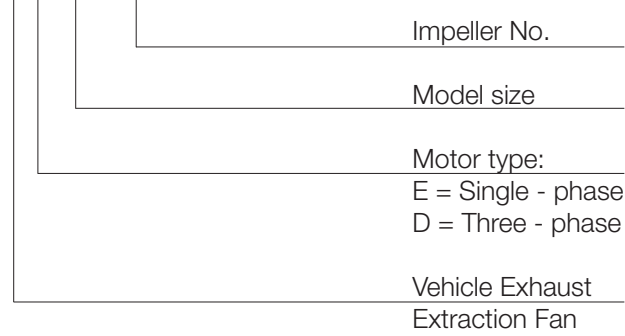

Fig.14

Technical Data

Table 4

Model Size	Speed [1/min]	Power [kW]	Current [A]	Capacitor [µf]	Max. Airflow [m³/h]	Sound Power Level [dB(A)]	Weight [KG]
---------------	------------------	---------------	----------------	-------------------	---------------------------	---------------------------------	----------------

(Power Supply: Single Phase 50Hz 220V)

VE 300-13	2800	0,37	2,73	10	1050	63	20,5
VE 300-21	2800	0,75	5,15	20	1560	66	27,0

(Power Supply: Three Phases 50Hz 400V)

VD 300-13	2800	0,37	0,94	-	1050	63	20,2
VD 300-18	2800	0,55	1,33	-	1220	64	20,9
VD 300-21	2800	0,75	1,81	-	1560	66	27,8
VD 320-30	2800	1,1	2,52	-	2600	68	37,2
VD 380-47	2800	2,2	4,69	-	3720	76	58,5
VD 400-58	2800	3,0	6,00	-	5660	86	82,5
VD 500-76	1450	1,1	2,74	-	4000	73	98,0
VD 500-76	2800	4,0	7,63	-	8000	88	113

- Note: 1, The volume airflow indicated above is measured in AMCA 210 chamber;
 2, The sound level are measured from the fan body when ducts are connected on both inlet and outlet side.
 3, Subject to change without prior notice.

VHS Dimensions

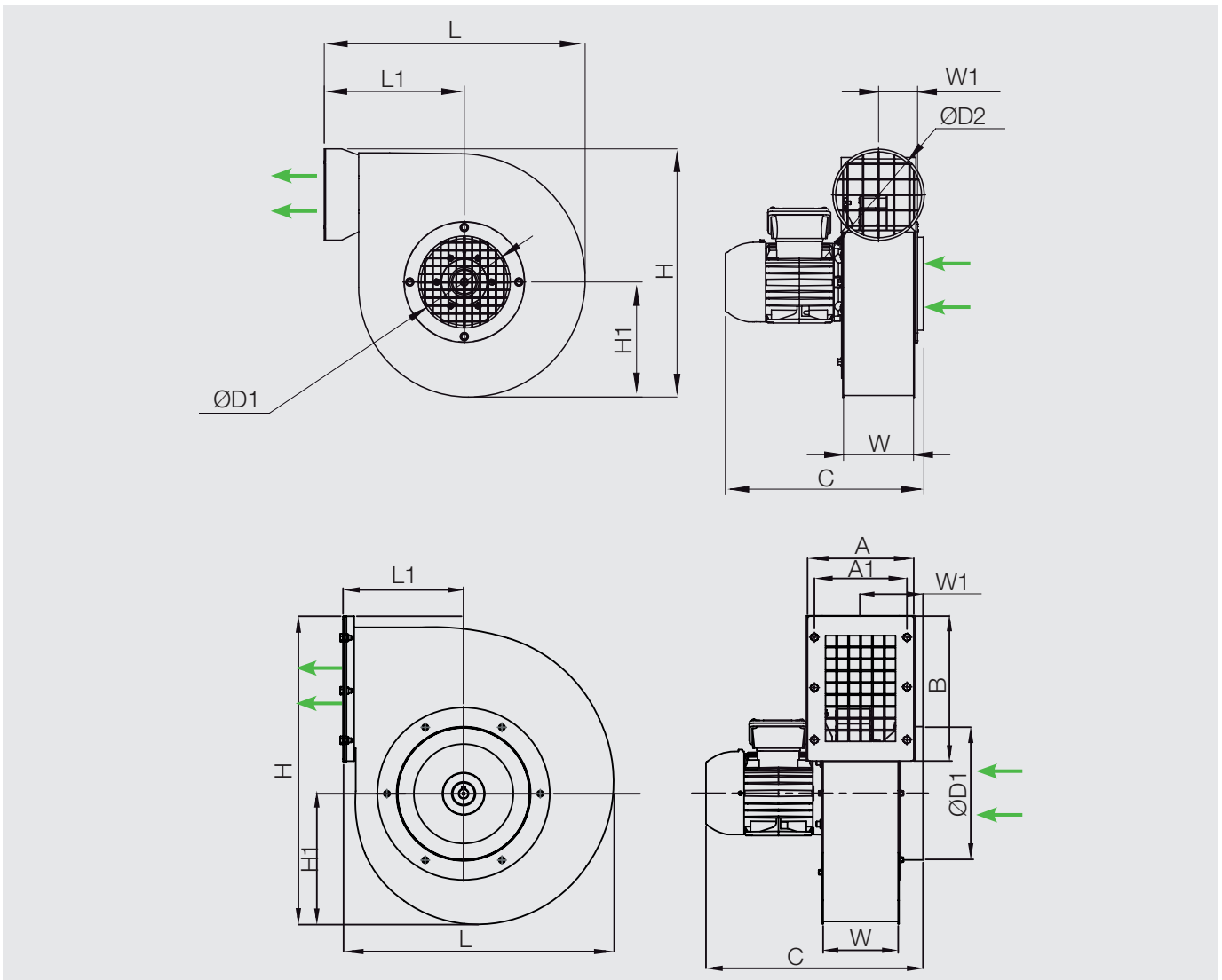

Table 5

Model	A	A1	B	C	D1	D2	H	H1	L	L1	W	W1
-	[mm]	[mm]	[mm]	[mm]	[mm]	[mm]	[mm]	[mm]	[mm]	[mm]	[mm]	[mm]
VE / VD 300-13	-	-	-	330	160	159	433	201	455	244	122	68
VE / VD 300-18	-	-	-	330	160	159	433	201	455	244	122	68
VE / VD 300-21	-	-	-	353	160	159	433	201	455	244	122	68
VE / VD 320-30	250	230	278	479	203	-	597	267	577	278	196	126
VE / VD 380-47	250	230	348	560	245	-	750	321	666	315	196	126

Note: Subject to change without prior notice.

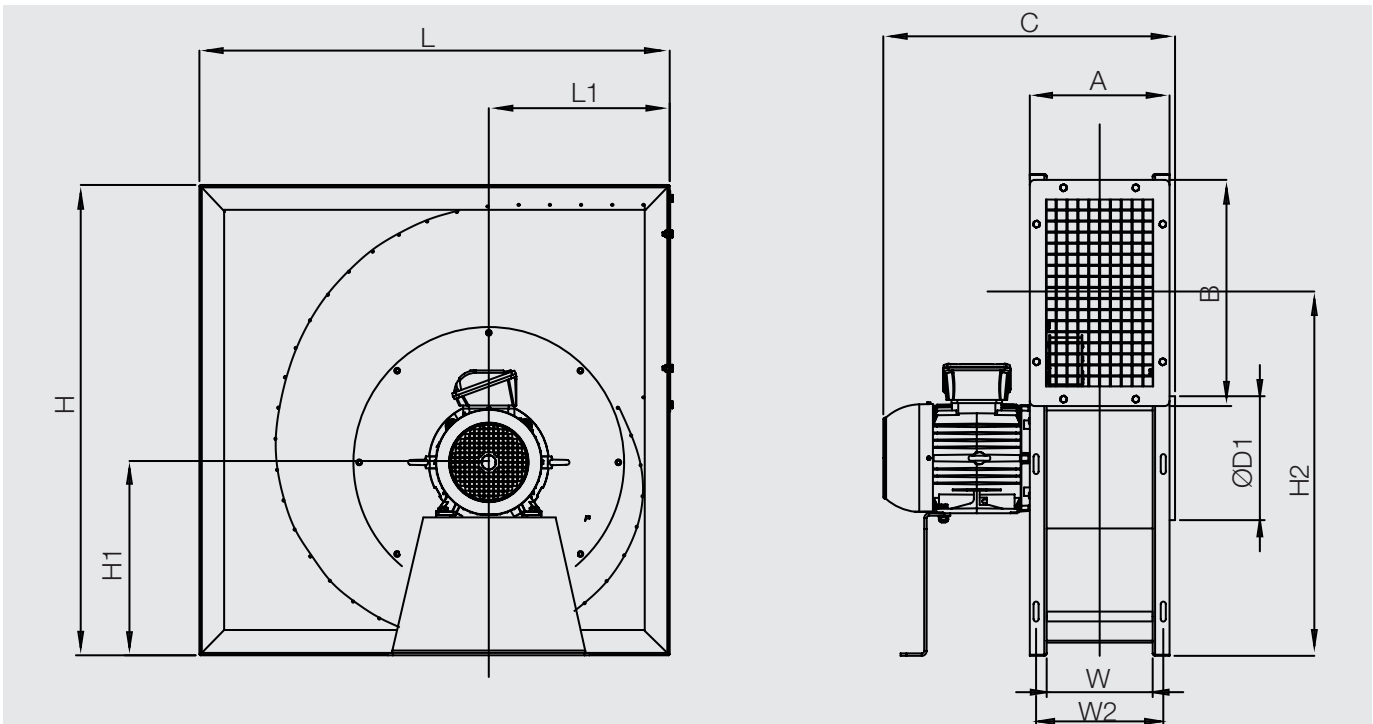

Table 6

Model	A	B	C	D1	D2	H	H1	H2	L	L1	W	W2
-	[mm]	[mm]	[mm]	[mm]	[mm]	[mm]	[mm]	[mm]	[mm]	[mm]	[mm]	[mm]
VE / VD 400-58	270	380	532	200	-	783	310	602	783	339	200	244
VD 500-76	290	460	606	252	-	980	402	741	980	377	220	264

Note: Subject to change without prior notice.



Note

The fan impeller are statically and dynamically balanced at the factory, and manufacture is subject to the strictest intermediate and end checks and is certified in accordance with DIN/EN/ISO 9001.

Conditions of use

The air should correspond to tender specifications, as the corresponding components are determined for this. If these are not listed in more detail, then the following applies:

The fans are suitable for the conveyance of

- › air containing car exhaust emissions
- › air which has little dust and grease content
- › gases and vapours which are non-explosive and only slightly aggressive in nature

Conditions of fitting

Please contact the manufacturer for more information in intend for other application or otherwise shall be considered as improper usage!



Warning

In particular, we especially draw your attention to the following points. Non-compliance can either result in considerable material damage or personal injury, or that the demanded fan output values are not attained.



Warning

The fan may not be operated without the necessary safety fittings. For this reason, protective screens on the fan inlet must be fitted at all times during operation in order to prevent access to rotating parts.

In order to avoid any damage to the Unit, specially to the rotor blades, you must prevent the possibility of loose parts being sucked in by the fan or of other items being able to find their way into the fan.

The fitting notes regarding inlet and outlet flow conditions are to be observed.

4 Transportation and Storage

4.1 Transportation

Wolter VHS and fans Units are packed at the factory to suit the respectively agreed mode of transportation. Transport the Unit in its original packaging.

- › Only use suitable means of transport, such as pallet trucks or fork-lift trucks.
- › If the fan is to be transported by hand, ensure that supporting and carrying loads are kept within reasonable limits for the personnel involved.



The following special hazards must be taken into account when transporting the equipment:

- › The transportation packaging does not prevent damage to the equipment through improper transportation.
- › The fans must not be dropped or thrown.
- › Sharp, protruding edges can lead to injury through cuts.



› Suspended loads can fall, which then constitutes a fatal hazard - stand well clear of suspended loads!

- › Parts which have been stacked too high can collapse.
- › If load-carrying devices other than those specified here are used, then this can lead to serious damage to the machine.
- › A risk of fire exists due to the easily flammable nature of the packaging materials
- › Do not use naked flames and do not smoke!
- › Read the chapter, "General Safety Notes".

4.2 Storage

- › Store the Unit in a dry, weather-protected location in its original packaging or protect it from the effects of dirt and the weather until final assembly.
- › Cover open pallets with tarpaulin sheets and protect the Unit from the effects of dirt and contaminants (e.g. swart, stones, wire etc.)
- › Avoid extremes of cold and heat.
- › Avoid lengthy storage periods (a maximum of two years is recommended).



Fig.15

- › The Unit is bolted on a skid and delivered with a ceiling or wall mounting bracket. Based on VHS being ordered, the duct connection includes either a 150 mm or a 200 mm duct connection hose collar.
- › The U-Clamp (19) Fig. 15 are placed on opposite for delivery purposes and for easy identifying the same position. The nozzle, U-Guide (42), M&I manual and other accessories, etc are placed on a box together with hose (37)

19

5 EC Declaration of Conformity

In accordance with Appendix II A of the EC Machinery Directive (89/392/EWG)

The manufacturer: Dongguan Wolter Chemco Ventilation Ltd.

No.69, Miao Bian Wang Road, Shipai, Dongguan, Guangdong, PRC China

hereby declares that the machine described in the following EC Directives:

Vehicle Exhaust Hose Reel: VHS 450-100; VHS 650-100; VHS 650-125; VHS 850-100; VHS 850-125; VHS 850-150;
VHS 1050-100; VHS 1050-125; VHS 1050-150; VHS 1050-200.

With Exhaust Fan: VE / VD 300-13; VE / VD 300-18; VE / VD 300-21; VE / VD 320-30; VE / VD 380-47;
VE / VD 400-58; VD 500-76.

meets the health and safety requirements of the following EC Directives:

In accordance with Machinery Directive (98/37/EG), Appendix II A in accordance with the Low Voltage Directive (73/23/EWG)

Harmonized standards applied:

EN 60204-1: Safety of machinery; electrical equipment of machines, Part 1: General requirements

EN 292: Safety of machinery; basic concepts, general principles for design

EN 294: Safety of machinery , Safety distances for the prevention of injuries within danger zones

IEC 60335-2-80: Household and similar electrical appliances - Safety - Part 2-80: Particular requirements for fans

IEC 60335-1:2010 + AMD1:2013 + AMD2:2016 CSV Consolidated version:

Household and similar electrical appliances - Safety - Part 1: General requirements

Note:

The compliance with EN 294 refers to the fitted contact safety device only, as it is part of the extent of delivery. The total compliance with EN 294 is the system manufacturer's or the contractor's responsibility.

EN 60034-1 / IEC 34-1

Rotating electrical machines: Part 1: Rating and performance

EN 60034-5

Rotating electrical machines - Part 5: Degrees of protection provided by the integral design of rotating electrical machines (IP code) - Classification

EN 60085-5

Electrical Insulation. Thermal evaluation and designation

EN ISO 12100:2010

Safety of machinery - General principles for design - Risk assessment and risk reduction

AMCA 300: Reverberant Room Method for Sound Testing of Fans

The ascertaining of the sound power level follows the reverberant room measurement method according to AMCA 300

AMCA 210: Laboratory Methods of Testing Fans for Certified Aerodynamic Performance rating

The performance curves provided in this catalogue were measured according to AMCA 210 in a test chamber.

If the machine is a single component of a complete equipment/machinery, the conformity of this equipment/machinery with the EC Machinery Directives has to be ensured before the initial operation.

Date: 25.02.2016



Nicholas Ang
Vice President

6 VHS Commissioning and Parts Replacement

6.1 Hose Reel Commissioning (assembly and retracting tension setting)

These tools are needed to install Unit:

- › Power Drill / Electric Screw gun.
- › General hand tools / wrenches
- › Screw drivers

Complete steps to install the HVS hose reel as shown in diagram:



Fig.16

- › Equalize the spring-tension
- › Set the tension on the exhaust reel according to the Pre-tension as per Fig.16. Turn the casing in the direction of the arrow as per arrow direction.

Example: 7.5 turn for 7.5 meter (18KG) 150mm dia. hose with single spring module (07) or 7.5 turn for 15 meter 150 dia. hose with double spring module (07) type

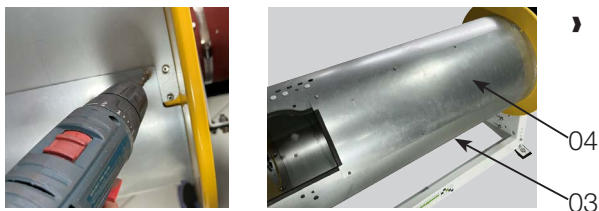

Fig.17

- › Dismantle casing cover (04) Fig. 17 (VHS 1050-200 version not required)



Fig.18

Fig.19

- › Carefully place the hose (37) inside the casing and recommend to place cardboard Fig.18 on casing edge to avoid cut on hose.
- › Mount the hose (37) to the hose bearing with collar(16) inside the reel casing (03) with a hose clip (40) Fig.19.



Fig.20

- › Place the protection strip (14) Fig.20 at the opening of the casing where the hose protrudes.



Fig.21

- › Bend hose (37) into a natural soft curve and fasten it using U clamp (19) provided Fig.21.



Fig.22



- › Re-mount the casing cover (04) Fig.22.



Fig.23



Fig.24

- › Mount hose stopper (20) with hose clip (40) so that the hose (37) can stop at a convenient height when it is reeled in Fig.23.
- › Mount the hose (37) onto the standard nozzle (43) Fig.24

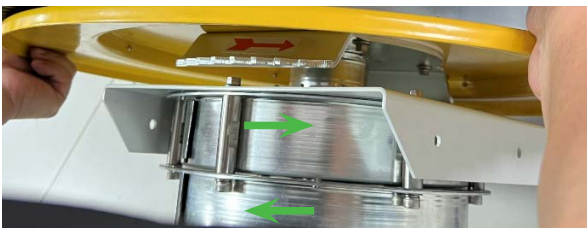

Fig.25

- › Carefully forward (→) and backward (←) to release the locking plate (15) Fig.25 and allow the hose (37) to coil back to its rest position. The VHS is ready for use now.

- Ø 150mm hose
- Ø 125mm hose
- Ø 100mm hose
- Ø 75mm hose



Fig.26

- › The base frame holes are pre-set for the correct diameter hose, as shown in Fig.26

VHS Pre-tension table

Hose Dia. (mm)	Hose Length (m)	Pre-tension (Turns)
100	5	5
	7.5	6
	10	7
125	5	6
	7.5	7
	10	8
150	5	6.5
	7.5	7.5
	10	6.5*
	15	7.5*
200	5	5
	7.5	7.5
	10	6*

* For double spring modules

Table 7



Caution

The pre-tension turns above vary on the type of hose being used. User should try-out with caution

How hose stopper works:

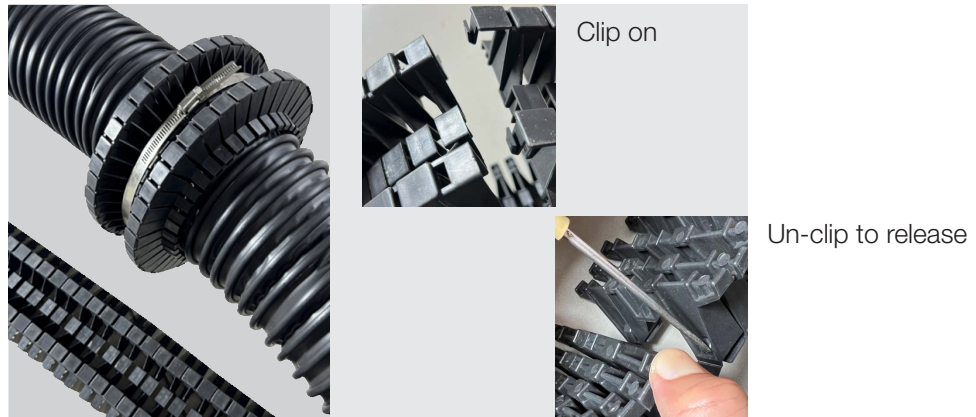

Fig.27

6.2 Mounting Installation Height and dimensions

6.2.1 Mounting Installation

Use the reach and mounting height chart for specific hose lengths and maximum hose reach.



Attention

When horizontally mounting a reel that contains either a 150 mm or 200 mm hose, it is recommended that you attach the hose so that it rotates around the "front" of the unit (away from the column or wall), as shown in Fig. 28.

This will prevent the hose (37) from scraping the horizontal base frame (08), or colliding with any items attached to the column or wall below the VHS.

Unit mounting on wall

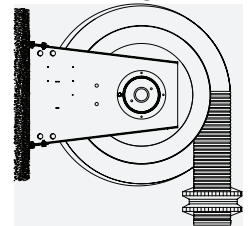

Fig.28



Caution

When the reel is mounted to a rigid structure like an iron beam or concrete Fig.29, then use the dimensions provided. However, when the reel is being mounted to porous or otherwise doubtful materials like hollow brick, threaded rod, lightweight concrete, plaster etc., please consult the manufacturer.

Unit hang on ceiling

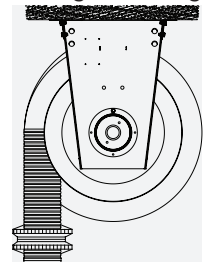

Fig.29

"1/4 turn" of the hose



Fig.30

Warning

After installation, operators must be made aware that a "quarter turn" of the hose should always remain on the reel casing, as shown in Fig. 30.

If the hose is pulled down completely, and the entire hose is removed from the unit, the recoil mechanism will be locked, and the hose reel will no longer retract the hose. If this occurs, the casing must be turned manually for the recoil mechanism to release.

6.2.2 Reach and mounting height

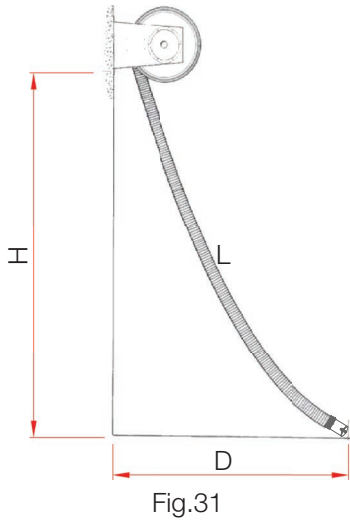

Mounting Height	Hose Length	Max. Reach	Hose Length	Max. Reach
H	L	D	L	D
[m]	[m]	[m]	[m]	[m]
3	7.5	6.2	-	-
3.5	7.5	5.9	10	8.5
4	7.5	5.5	10	8.3
4.5	7.5	5.2	10	8.0
5	7.5	4.7	10	7.7
5.5	-	-	10	7.4

Table 8

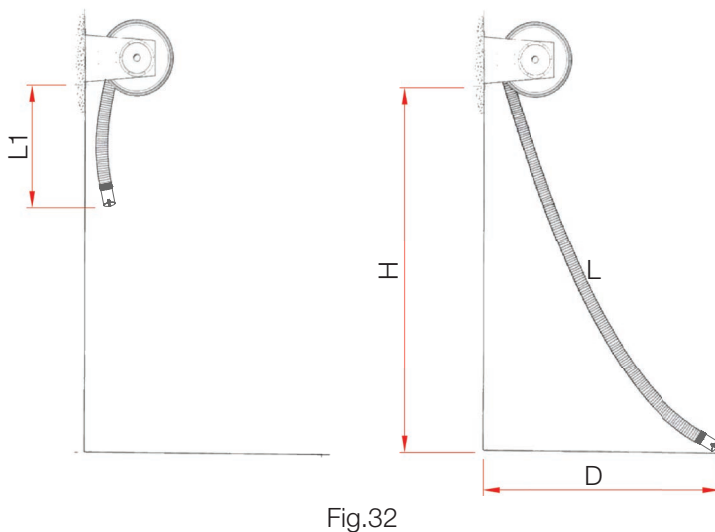

Mounting Height	Hose Length	Max. Reach	At Rest
H	L	D	L1
[m]	[m]	[m]	[m]
5	12.5	10.6	0
5.5		10.3	
6		10.0	
6.5		9.7	
7		9.4	
5.5	15	12.9	2.5
6		12.6	
6.5		12.3	
7		12.1	
7.5		11.8	

Table 9

Note: Remember to consider the hose reel's lifting capacity when mounting at higher elevations, factoring in the Total weight of the hose (37), nozzle (43) and hose stopper (20).

6.3 Operation

The operator pulls the hose (37) to lock it into the required position and pulls a second time to recoil the hose on the reel. The hose stopper (20) is set to the required height when returning the hose to the reel.

6.4 Mounting options

6.4.1 Direct mount fan

The VHS includes ceiling or wall mounting attachment foot. All VHS versions except for 1050-200 can be connected to a central exhaust system or fitted with a fan.

First, mount the fan with the reel upside down on the floor (Fan are available in LG270 or RD 270) and then mount the complete reel to its intended position, as shown below.



Fig.33



Fig.34
45

- › First, mount the fan with the reel upside down on the floor (Fan are available in LG270 or RD 270) and then mount the complete reel to its intended position.
Example of a LG 270 fan (view from motor side, fan outlet at anti clock wise) Fig.33.
- › With hose reel securely installed in position or placed on a level working surface, insert the pedestal support (45) with the bolts and hand tighten the nuts on to fan plate(12) Fig.34.



Fig.35
44

- › Place the fan with motor (44) on the pedestal support (45); Align fan bolt holes with the holes in the Pedestal support (45). Insert bolts and tighten slightly;
Slide the pedestal support (45) up and down parallel to the fan plate (12) center to align with outlet collar (13);
Tighten bolts to ensure the unit is properly secured Fig.35.

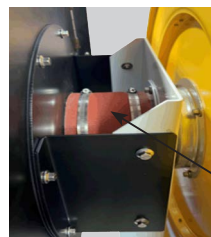

Fig.36
39

- › Place HT flexible connector (39) between fan inlet spigot plate (47) and outlet collar (13);
Tighten the HT flexible connectors (39) with hose clip (40) Fig.36;
- › Stiffen the mounting by bolting 2 pieces of angle brackets (46) on fan inlet spigot plate (47) to fan plate (12)

Note: Direct mounted fans are of either VE (1P) or VD (3P) model such as 300-13, 300-18, 300-21 or 320-30.

6.4.2 Micro Switch

Optional available : Please contact factory for more information

6.5 Maintenance

6.5.1 Replacing the exhaust hose (37)



Fig.37

- › Uncoil hose (37) completely and lock reel in its most extended (Pre-tension) position Fig.37;



- › Dismantle protection strip (14), casing cover (04), and U-clamp (19) Fig.38.



Fig.39

- › Loosen hose clip (40) on the connecting the hose bearing with collar (16) and remove the old hose Fig.39.



Fig.40

- › Attach new hose (37), the surface of the hose should be protected with card board to avoid in case of any cut damages Fig.40.



Fig.41

- › Attach new hose (37), the surface of the hose should be protected with card board to avoid in case of any cut damages Fig.41.



Fig.42

- › Carefully bend the hose (37) into a natural soft curve and fasten it using U-clamp (19) Fig.42.

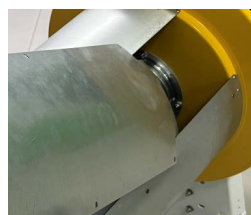

Fig.43

- › Re-install the casing cover (04) Fig.43.

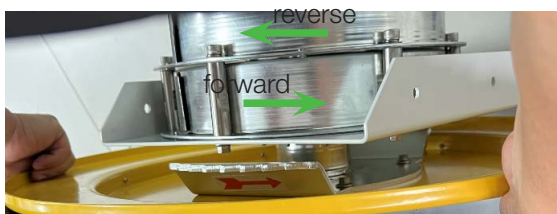

Fig.44

- › Carefully forward (→) and backward (←) to release the Locking plate (15) and allow the hose (37) to coil back to its rest position Fig.44.
The VHS is ready for use now.



Fig.45



Fig.46

- › Re-mount hose stopper (20) Fig.45 and the standard nozzle (43) with clamp Fig.46 and the reel is now ready for use.

6.5.2 Replacing the spring module (07)

Noted on the hose stopper (20) position. Take off the stopper (20) and nozzle (43) with adapter (if any)



Fig.47

- › Allow the hose (37) to completely coil onto the reel Fig.47.



Fig.48

- › Revolve the reel about a few revolutions in reverse (←) arrow direction in order to equalize the spring-tension (if the spring still functions) Fig.48.

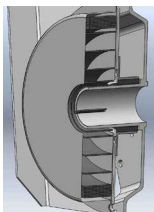

Fig.51

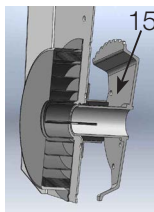

Fig.50

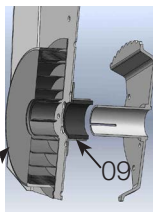

Fig.49

- › Unscrew all socket head cap screws at the spring module (07) Fig.51. Mark the position of the spring module (07).
- › Put the new spring module (07) in position. Ensure the Locking plate (15) with hollow shaft fit well to the spring catch Fig.49 and Fig.50. Slide in the new spring module (07) Fig.51. Tighten the bolts evenly.



Fig.52

- › Spring module (07) should rest at an equalized pre-tension stage by now, tension on the exhaust reel according to the pre-tension table as per table 7 Fig.52.

Turn the casing together with the coiled hose (37) in the direction of the arrow as per arrow indicator (→).

Example : 7.5 turn for 7.5 meter (18KG) 150mm dia. hose with single spring module (07) or 7.5 turn for 15 meter 150mm dia. hose with double spring module (07) type.



Fig.53



Fig.54

- › Placed the hose stopper (20) Fig.53 and nozzle (43) Fig.54 adapter (if any) in same measured position.

6.5.3 Replacing bearings

6.5.3.1 Replacing the Drive Bearing with Collar (09) on the Drive Plate (01)

Noted on the hose stopper (20) position. Take off the stopper (20) and nozzle (43) with adapter (if any)



Fig.55

- › Unwind the hose in a slow and controlled manner (reverse arrow direction). Count the number of winds on the reel, and make note of it, as you will need to know this number when you re-assemble the unit Fig.55.

The nos of turns can also refer to Table 7



Fig.56

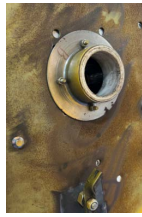

Fig.57

- Place a support under the reel casing (03) and loosen the 4 bolts and nuts holding the drive plate (01) and the base frame (08) Fig.56.

- Once the bolts have been removed, carefully remove the drive plate (01), and ensure the hose (37) and reel casing (03) is safely and securely supported to prevent damage and are place in a safe area to prevent any damage or dents Fig.57.



Fig.58

- Remove the 3 bolts holding the single spring module (C) or 6 bolts if of double spring module from drive plate (01). Prior to lifting the spring module (07) off, take note of the spring's orientation Fig.58.



Fig.59



Fig.60

- Once the spring module (07) has been removed, remove the 6 bolts securing the damaged drive bearing with collar (09) from the drive plate (01) Fig.59. Replace with a complete new drive bearing with collar (09) Fig.60.

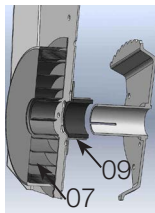

Fig.61

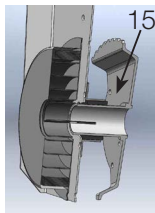

Fig.62

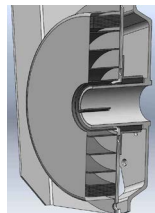

Fig.63

- Follow the steps above in reverse to assemble, ensure the Locking plate (15) with hollow shaft fit well to the spring catch Fig.61~63.

- Install the complete drive plate (01), drive bearing with collar (09), spring module (07) onto the base frame (08) with 4 bolts and nuts the hose (37) remain at the reel casing (03).



Fig.64

- Spring module (07) should rest at an equalized pre-tension stage by now Fig.64, tension on the exhaust reel according to the pre-tension table as per Table 7.

Turn the casing together with the coiled hose (37) in the direction of the arrow (→) as per arrow indicator.

Example : 7.5 turn for 7.5 meter (18KG) 150mm dia. hose with single spring module (07) or 7.5 turn for 15 meter 150mm dia. hose with double spring module (07) type.



Fig.65



Fig.66

- Placed the hose stopper (20) Fig.65 and nozzle (43) Fig.66 adapter (if any) in same measured position.

The VHS is ready to work now.

6.5.3.2 To replace the hose bearing with collar (16) on the fan plate (12)

Noted on the hose stopper (20) position. Take off the stopper (20) and nozzle (43) with adapter (if any)



Fig.67



Fig.68

- › To safely perform this operation, it is recommended to remove the fan with 8 bolts and nuts and the HT flexible connector Fig.67 from the VHS Fan Plate (12) structure and stand it on the floor Fig.68.



Fig.69

- › Unwind the hose in a slow and controlled manner (reverse arrow direction). Count the number of winds on the reel, and make note of it, as you will need to know this number when you re-assemble the unit Fig.69. The nos of turns can also refer to Table 7



Fig.70



Fig.71

- › Uncoil hose (37) completely Fig.70. Dismantle protection strip (14), casing cover (04), and U-clamp (19) Fig.71.

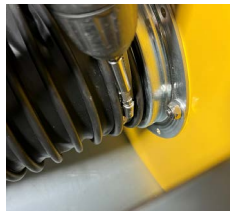

Fig.72

- › Loosen hose clip (40) on the connecting the hose bearing with collar and remove the hose Fig.72. Ensure the hose (37) is prevent damage and are place in a safe area to prevent any damage or dents.



Fig.73



Fig.74

- › Place a support under the reel casing (03) and loosen the 4 bolts holding the fan plate (12) and the base frame (08) Fig.73.
- › Once the bolts have been removed, carefully remove the fan plate (12), and ensure the reel casing (03) is safely and securely supported to prevent damage Fig.74.

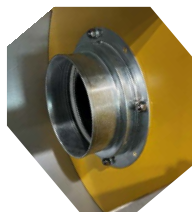

Fig.75

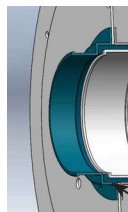

Fig.76

- › Once the fan plate (12) has been removed, remove the 4 or 8 bolts and nuts that securing the damaged drive hose bearing with collar (16) from the fan plate (12) Fig.75. Replace with a complete new hose bearing with collar (16) Fig.76.



Fig.77

- › Assembly back the fan plate (12), and ensure the reel casing (03) is safely and securely supported. Bolts on the fan plate with 4 bolts and nuts together with the base frame (08) in position Fig.77.

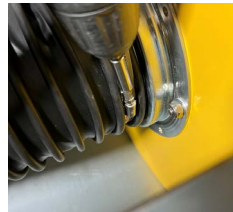

Fig.78

- › Hose (37) surface are recommended to be safely protected by cardboard. Carefully mount the hose (37)_on to the hose bearing with collar (16) in position Fig.78.



Fig.79

- › Re-install the protection strip (14) at the opening of the casing where the hose protrudes Fig.79.



Fig.80

- › Bend the hose (37) into a natural soft curve and re-fasten it using U-clamp (19) Fig.80.



Fig.81

- › Re-mount the casing cover (04) Fig.81.

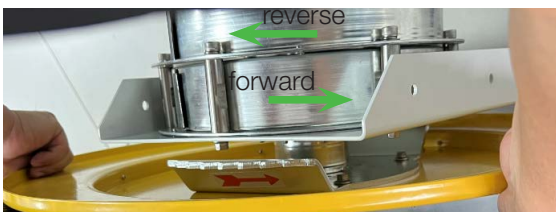

Fig.82

- › Carefully forward (→) and backward (←) to release the Locking plate (15) and Allow the hose (37) to coil back to its rest position Fig.82. The VHS is ready for use now



Fig.83



Fig.84

- › Re-mount hose stopper (20) Fig. 83 and the Standard Nozzle (43) with clamp Fig. 84.

7 Exhaust Fan VE / VD Installation

When lifting the fan into its position on the ceiling during installation, secure it from falling down until it is securely installed.



Attention: Make the electrical connection in accordance with the technical connection conditions and the relevant regulations!

The motor is equipped with thermal contacts, they must be properly checked if trip-off frequently. Failure to do so will void the warranty.



Before checking the direction of rotation:

Remove foreign bodies from the fan area.

Protective screen must be fitted.

Check the direction of travel in accordance with the arrow on the housing by switching on and off very quickly.

8 Fan Initial Start-up

The following points are to be observed in order to avoid damage to the machinery or life-threatening injury during initial start-up:

- › Only qualified personnel may carry out the machine's initial start-up and this must take place in compliance with the safety notes.
- › Prior to initial start-up, check that all tools and foreign bodies have been removed from the machine.
- › Activate all safety devices and Emergency Stop switches prior to initial start-up.
- › Check the motor's direction of travel prior to initial start-up.
- › Read the chapter, "General Safety Notes".

8.1 Checks prior to initial start-up

Proceed with the fan's initial start-up in the following sequence:

- › Check that the mechanical assembly has been carried out properly
- › Remove foreign bodies located in the suction and outflow areas and in the fan space



Check that the electrical installation has been completed in accordance with regulations

Does the mains voltage match the motor voltage specified on the rating plate?

Is the switchgear used suitable for the motor both with respect to the switching functions to be carried out and also to the switching conditions and switched output of the motor?

Is the motor protection system set correctly with regard to the motor's nominal current? The setting must be carried out in accordance with the corresponding details contained on the motor output plate.

Has the motor been connected correctly in accordance with the wiring diagram?

The connection schematic supplied must be exactly applies for the connection of the motor.



Accident prevention

Inlet protective screen must be fitted on the inlet of the fan to meet safety regulations.

8.2 Starting up the fan for the first time

Only put the fan into operation after it has been assembled in accordance with the regulations!

- › Put the fan into operation.
- › Monitor its correct function (quiet running, vibration, imbalance, power consumption, control-ability)



Always keep nozzle openings clear and secure and with handle cover.
Check protective screens or protective anti-intrusion fittings for dirt, and clean if necessary!

8.3 Checks after initial start-up

Check the mechanical connections of the fan after initial start-up.

9 Trouble Shooting

9.1 Fan Help with Malfunctions

The following points must be observed in order to avoid damage to the machinery or life-threatening injury when eliminating machine malfunctions:

- › Only eliminate any malfunction if you have the specified qualifications necessary for the task.
- › First of all ensure that the machine cannot be switched on inadvertently, by locking the equipment's off switch or control cabinet by means of a padlock.
- › Secure the hazardous area with respect to moving machine parts.
- › Read the chapter "General Safety Notes".

9.2 Tabular overview of possible malfunctions and aids in eliminating those malfunctions

Symptom	Cause	Elimination
Motor or motor control system switches off.	Motor too hot, thermo contact activates.	Allow the motor to cool off. The fan will start itself again. Check whether: <ul style="list-style-type: none"> - The conveyed medium is too hot - All phases are evenly loaded and connected - Operating point does not match the lay-out - Rotor blocked
Air output incorrect	Incorrect direction	Change the direction of travel (see electrical assembly)
	Fan assembled incorrectly	Either the rotor is incorrectly mounted on the motor shaft or the whole motor-fan-assembly has been incorrectly fitted into the installation. Switch off the fan. Correct the incorrect assembly (rotor or motor-fan-assembly).
	Rotor blocked	Switch off the fan. Remove the blockage. Ensure that the accident prevention regulations are observed in the process.
	Rotor defective	Switch off the fan. Dismantle the rotor and fit a new one.

<p>Fan is labouring under load, air flow is periodically interrupted</p>	<p>Fan is operating at an unfavorable duty point</p>	<p>Make sure there are no obstacles at the nozzle. Please contact the Wolter for assistance. If this laboured operation of the fan continues over a prolonged period, the rotor will damage! Check if periodic maintenance and cleaning of guard was undertaken. Check against MC001.</p>
--	--	---

Table 10

10 General Maintenance

The following safety notes must be observed when maintaining the machine - life-threatening injuries to personnel, damage to the machine and other material damage, as well as environmental damage, will be avoided in this way.

- › Cleaning, lubrication and maintenance work may only be carried out by authorised operating personnel operating instructions are to be observed.
- › Repair work may only be carried out by authorised craftsmen - accident prevention regulations are to be observed.
- › Secure the operational area over a large area prior to the commencement of maintenance work.
- › The specified sequence of the working stages is to be observed exactly.
- › All work on the machine's electrical equipment may only be carried out by trained electricians.
- › Self-locking screws and nuts are always to be renewed.
- › All specified screw torque settings are to be observed precisely.
- › Read the chapter "General Safety Notes".



If the fan is equipped with a combined terminal box / repair switch, it is still necessary to disconnect the mains supply to the terminal box when performing electrical maintenance or repairs that require opening the terminal box!



Setting the repair switch to the "OFF" position cuts off the power supply from the terminal box to the motor, but the connection terminals inside the terminal box are still energized! When unscrewing the terminal box cover, there is a danger of contact between the cover and the connection terminals, therefore the mains supply **MUST** be disconnected to avoid the danger of electrical shock!

10.1 VE / VD Servicing

The fan housing, impeller and motor are subject to natural wear and tear through the action of dust, acidic and corrosive vapours, as well as the gases which are mixed into the conveyed flow. The type and concentration of the dust, as well as the gases and vapours, can lead to deposits, abrasion and corrosion at the impeller and housing.

The materials can be attacked by this natural wear and tear to the extent that they can no longer stand up to the strains imposed on them. Unevenly distributed deposits on the impeller may lead to an imbalanced state and thus to noisy running, which in turn can result in damage to the impeller and motor bearing. Deposits in the housing lead to a narrowing of the available cross-sectional area or to a roughening of the housing panels and can thus have an unfavorable effect on the fan's output duty. Should the checks, the regularity of which depend on the conveyed media and other operating conditions which differ in each individual case, reveal only slight wear and tear, then the individual parts must be cleaned in good time, or replaced if necessary.

10.2 Prior to all servicing work:

- › Bring the fan to a halt in the prescribed manner and completely isolate the fan from the mains supply!
- › Wait until the impeller has come to a halt!
- › Ensure that the machine cannot be switched on again!
- › Clean the fan components (fan housing, inlet cone, impeller, motor etc), Do not use high-pressure water devices for cleaning



Only use cleaning agents generally available through the trade and in compliance with the prescribed safety measures. Do not use scratching or scraping tools (protective surface coating will be damaged).



Fig.85



Fig.86

- › If required, remove the HT flexible connector. 2 Fig. 85 fan angle support, inlet cone, impeller from the fan housing Fig. 86.
- › Do not bend the impeller blades!
- › Do not overload the motor!

10.3 Recommended periodic inspection intervals

- › Fans used for normal fume and gas extraction only: 6 months
- › Fans used constantly for CO-exhaust and adverse site condition: 3 months

10.4 Periodic inspection checks

- › Visual inspection of motor, impeller, fan housing and electric connection for damages, dirt and dust deposits (if any)
- › Check for unusual noises or vibration during operation
- › Check tightness and security of fan suspension as per Maintenance Schedule MC001 recommendation and to avoid void on warranty

10.5 VE / VD Maintenance Schedule MC001

Project Name:	FAN TYPE	Maintenance No.:	
Fan Model: VE / VD Series	Centrifugal	Examiner	Date
Size: 300-13, 300-18, 300-21, 320-30, 380-47, 400-58, 500-76			
JOB STEPS			
First inspection			
- Inspection of transport damages	X		
- Inspection of fan housing	X		
- Inspection of impeller	X		
- Inspection of wire guard	X		
- Inspection of cable gland and wire connection			
Inspection after mounting			
- All damages to paint rectified	X		
Inspection after commissioning			
- Direction of rotation checked	X		
- Abnormal Vibration during operation	X		
- Abnormal Sound pressure level	X		
- Electrical values measured Voltage / Frequency / Current.....V /Hz /A	X		
WORKING STEP			
Maintenance (at least every 6 months and depend on site condition)			
- Bearing status checked / re-greased	X		
- Visual fan housing check	X		
- Visual impeller check	X		
- Visual check for corrosion	X		
- Visual motor check	X		
- Sound pressure level check	X		
- Check all screw connections of suspension construction	X		
- Electrical values measured: Voltage / Frequency / Current.....V /Hz /A	X		
- Maintenance (at least every 3 months depend on site condition)	X		
- Clean fan inlet and check any blockage	X		
- Maintenance (at least every 1 to 2 months depend on site conditon)			
- Wire Guard	X		
- Clean fan inlet and blockage check			

Table 11

11 The Unit Pressure Loss Calculation

The fall of pressure in a air duct system or in a hose is mainly determined by the air velocity in that system. The higher the velocity is, the higher the pressure loss will be. And the higher the pressure loss is, the less air the fan will extract. Use the Pressure loss chart below Fig. 89 to identify a suitable fan regarding the relationship between airflow and pressure loss.

In a ventilation system with many extraction devices and long suction ducts, you can minimize pressure loss by increasing the size of the ducting. This will also ensure even velocity throughout the system.

When 1200 ~ 1350 m³/h is needed, Wolter recommends a 150 mm hose. A 200 mm hose can be used for larger applications, as it supports larger engines operating under load. For those cases, the exhaust flow and temperature increase dramatically. Air velocity in ducting: 17,8 - 22,9 m/s.

The chart below shows the pressure loss in the hose reels a different airflows. Refer to the Airflow volume: general guidelines table below for the vehicle, airflow and hose diameter guidelines. The curves show these combinations of hose reel/hose diameter/hose length (uncoiled position).



We recommend that you confirm existing exhaust temperatures to ensure proper hose, fan and airflow selection

Vehicle Serviced	Airflow	Hose Diameter
-	[CMH]	[mm]
Motorcycles / Automobile	450 ~ 550	Ø 100
Trucks (Public works, Rental fleets, etc.)	825 ~ 950	Ø 125
Heavy Duty Trucks	1050 ~ 1400	Ø 150
Off-Road (Constr., Compressor Tests, etc.)	1650 ~ 2400	Ø 200

Table 12

Nr	Hose Diameter	Length
-	[mm]	[m]
A1	Ø 100	7.5
A2	Ø 100	10
A3	Ø 100	12.5
A4	Ø 100	15
B1	Ø 125	7.5
B2	Ø 125	10
B3	Ø 125	12.5
B4	Ø 125	15
C1	Ø 150	7.5
C2	Ø 150	10
C3	Ø 150	12.5
C4	Ø 150	15
D1	Ø 200	7.5
D2	Ø 200	10
D3	Ø 200	12.5
D4	Ø 200	15

Table 13

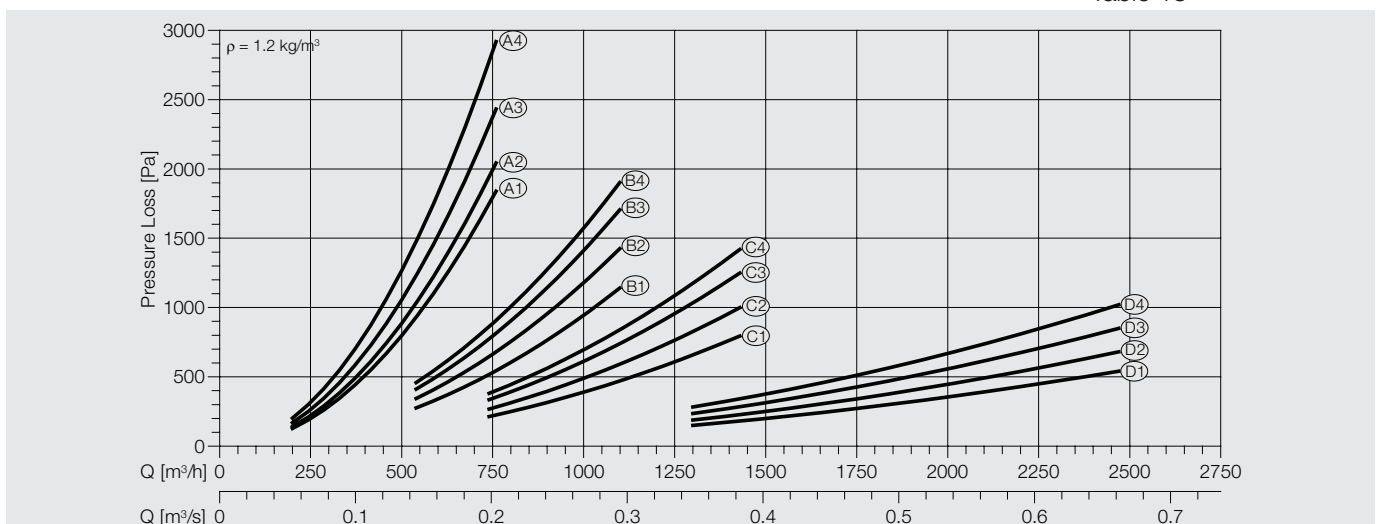
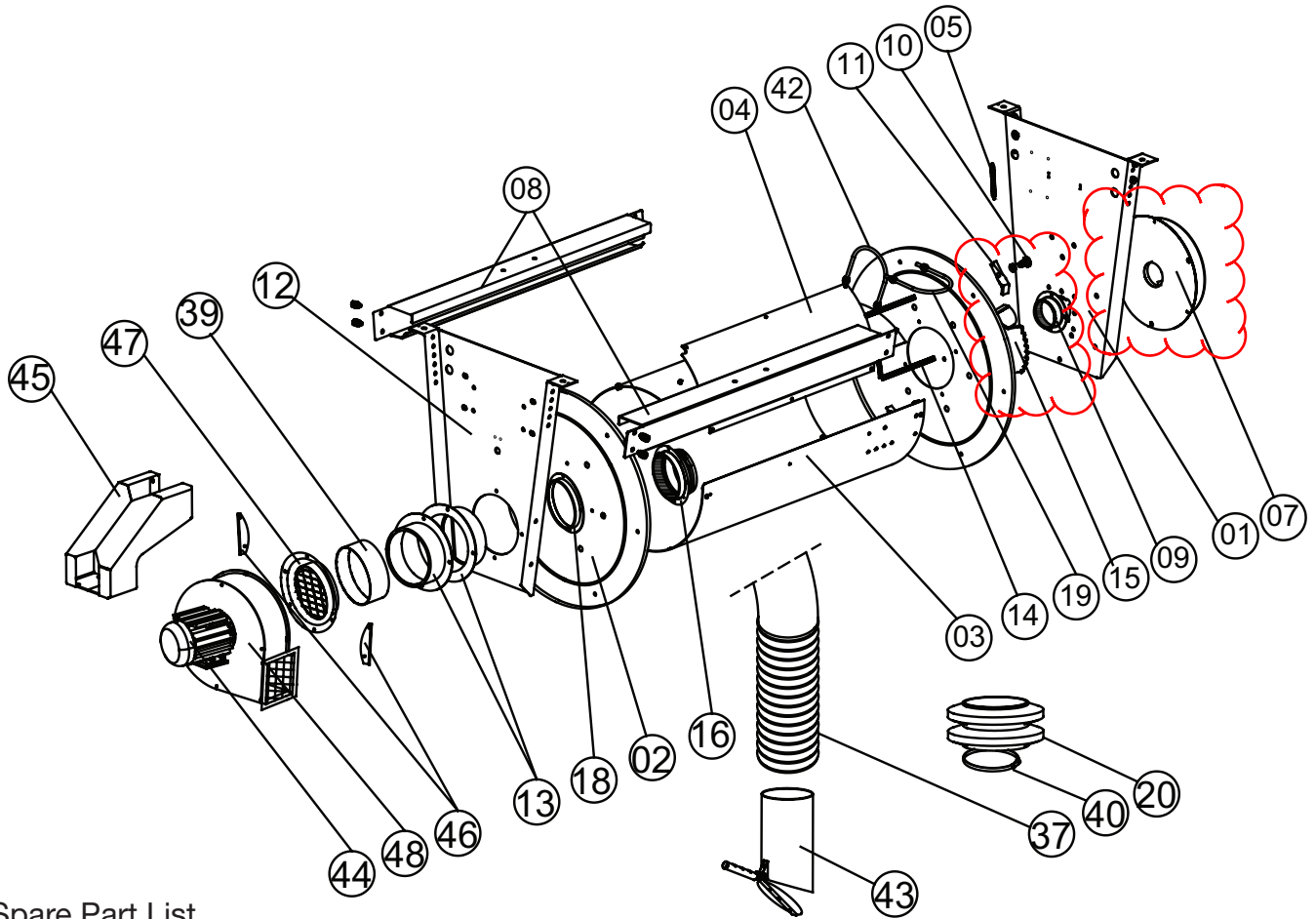

Fig.87

12 Spare Parts



Spare Part List

No	Part Name	VHS-850	VHS-1050	No	Part Name	VHS-850	VHS-1050
1	Drive Plate	01	01	13	Outlet collar	13	13
2	Casing Sideplate	02	02	14	Protection Strip	14	14
3	Reel Casing	03	03	15	Locking Plate	15	15
4	Casing Cover	04	04	16	Hose bearing c/w collar	16	16
5	Toggle Spring	05	05	18	Fixed Collar	18	18
7	Spring Module	07	07	19	U-Clamp	19	19
8	Base Frame	08	08	20	Hose Stopper	20	20
9	Drive bearing c/w collar	09	09	37	Hose	37	37
10	Toggle Shoulder Bolt	10	10	40	Hose Clip	40	40
11	Toggle Leg	11	11	42	U-Guide	42	42
12	Fan Plate	12	12	43	Standard Nozzle	43	43
No	Part Name	VD300-21	VD320-30	No	Part Name	VD300-21	VD320-30
39	HT Flexible connector	39	39	46	Angle bracket	46	46
44	Motor	44	44	47	Fan inlet spigot	47	47
45	Pedestal support	45	45	48	Fan Casing	48	48

Example: Order No VHS 1050-07 for Hose Reel model VHS1050 Spring Module)

Sales Network

Deutschland

Wolter GmbH.
Maschinen-und Apparatebau KG.
DE-76316 Malsch
T +49 (0) 72 04 / 92 01 0
F +49 (0) 72 04 / 92 01 11
info@wolter.eu

Europe

Denmark:

L.ØLAND VENTILATION A/S
DK-2605 Brøndby
T +45 (0) 70 / 20 19 11
salg@airforce.dk

Netherlands:

DE WIT Ventilatoren BV
NL-3821 CG Amersfoort
T +31 (0) 33 / 76 00 240
info@dewitventilatoren.nl

Sweden:

Nordisk Ventilator AB
SE-142 50 Skogås
T +46 (0) 8 / 72 70 250
se@nordiskventilator.se

Switzerland:

Anson AG Zürich
CH-8055 Zürich
T +41 (0) 44 / 46 11 111
F +41 (0) 44 / 46 13 111
info@anson.ch

OZ Tech SA

CH-1122 Romanel-sur-Morges
T +41 (0) 76 / 41 11 572
info@oztech.ch

United Kingdom:

Wolter (UK) Ltd.
GB-Leicestershire LE65 1AL
T +44 (0) 15 30 / 41 24 73
info@wolteruk.com

Middle East

UAE, Saudi Arabia, Qatar, Lebanon:

Please contact Wolter head office

Wolter GmbH.

Maschinen-und Apparatebau KG.
DE-76316 Malsch
T +49 (0) 72 04 / 92 01 0
F +49 (0) 72 04 / 92 01 11
info@wolter.eu

Asia

China:

Guangdong Wolter Chemco Ventilation Ltd.
Boluo, Huizhou, Guangdong

Dongguan Wolter Chemco Ventilation Ltd.

Shipai, Dongguan, Guangdong
T +86 (0) 769 / 8655 7298
F +86 (0) 769 / 8655 7278
info@wolter.com.hk

Taizhou Wolter Ventilation Co. Ltd.

Hengjie, Luqiao District,
Taizhou, Zhejiang
T +86 (0) 576 / 26 22 666 (26 52 888)
F +86 (0) 576 / 26 56 830

China - Hong Kong, Macau:

Wolter Asia Ltd
Kowloon, Hong Kong
T +852 (0) 2456 0198
F +852 (0) 2456 0290
info@wolter.com.hk

China - Taiwan:

Waxlink International Co., Ltd.
8F-2 No.218 Roosevelt Rd.,
Sec.6, Taipei, Taiwan
T +886 (0) 2 / 8932 1196
F +886 (0) 2 / 8932 1197
waxlink@mail.waxlinktw.com

India:

Wolter Ventilators India Pvt. Ltd.
867 D, Block-A, Sushant Lok, Phase-I,
Gurgaon - 122009 (Haryana)
T +91 (0) 124 2577797, 4261001-3
sales@wolterindia.in

Korea:

Kaceco-Wolter
14-1, Dang-dong, Gunpo-shi,
Gyeonggi-do
T +(82) 0 31 / 4773 104
F +(82) 0 31 / 4773 132
wolter@kaceco.com
info@kaceco.com

Malaysia:

Vibrantech (M) Sdn Bhd.
47200 Petaling Jaya Selangor
T +603 (0) 7847 3500
F +603 (0) 7847 3380
sales@vibrantech-sb.com

Singapore:

Wolter Pte. Ltd.
SG-569738 Singapore
T +65 (0) 63 / 52 95 48
F +65 (0) 63 / 52 95 47
info@wolterfans.com.sg

Thailand:

Wolter Ventilation Co., Ltd.
Thamai Kratumban Samutsakorn
741 10 Thailand
T +66 (0) 84 555 2936
kongsakol@wolterfan.com

Australia

The Sydney Fan Company.
NSW 2147, Sydney, Australia
T +61 (0) 2 / 9624 4000
F +61 (0) 2 / 9624 4100
sales@thesydneyfancompany.com

Wolter GmbH Maschinen-und Apparatebau KG

Am Wasen 11
DE-76316 Malsch / Germany
T +49 (0) 72 04 / 92 01 0
F +49 (0) 72 04 / 92 01 11
www.wolter.eu
info@wolter.eu

