

Centrifugal Fans

- backward curved impellers
- single inlet
- belt driven

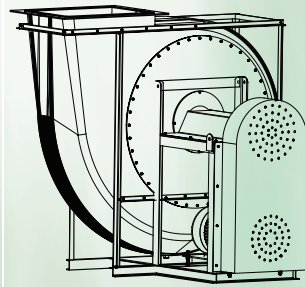
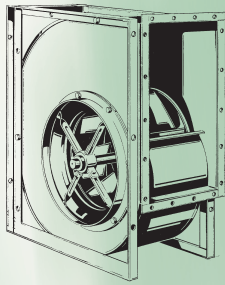

Air in Motion.
Wolter Fans.

M08.HRE

wolter 

Table of Content



Contents	Page 1
Technical description	Page 2
General information	Page 2
Fan casings	Page 2
Impellers	Page 2
Shaped inlets	Page 2
Shafts	Page 2
Bearings	Page 2
Fan type code	Page 3
Sound levels	Page 3
Performance curves	Page 3
AMCA FEG Rating	Page 5
Performance curves	Page 6
Fan energy index	Page 23
Dimensions	Page 27
Technical informations	Page 33
Fan Laws - Proportional Laws	Page 33
Coordination fan plant	Page 34
1. Characteristic Fan Curve	Page 34
2. Characteristic Curve of the Plant (Resistance Parabola)	Page 34
3. Coordination between Fan and Plant	Page 34
Operating and maintenance instructions	Page 35

General information

This range of **Wolter** fans is the result of many years of research and development. The efficiency of all the fans is guaranteed through specific volume figures at maximum pressure differentials. Excellent performance and minimal noise levels are the features of this new fan range.

These centrifugal fans are designed for the conveyance of clean air and non-aggressive steam and gases at a temperature range from -30°C to +80°C (22°F to 176°F). For smoke exhaust & air relief system operations, the fans are also certified for higher temperatures of up to 600°C for up to 4 hours in accordance to EN 12101-3:2015

Type: HRE (SISW backward curved).

Computer design allows for interchange-ability of components which ultimately provides an economy product.







Component dimensions are in accordance with DIN 323 section R 20 which means that the nominal size corresponds with the outside diameter of the impeller.

Fan casings

The machine folded scroll is made of galvanized sheet steel as standard. Predrilled holes are located in the side plates to fix mounting frames. It provides for easy installation. The outlet flanges are in accordance with international standards DIN 24193 sheet 2. Stainless steel or epoxy painted mild steel material as options.

Versions of casing

High performance centrifugal fan with folded galvanized scroll as standard or stainless steel / epoxy painted mild steel material as options:

Version	HRE	Size Range	Description
00		315 ... 450	without accessories
01		315 ... 450	with standard outlet flange
02		315 ... 450	without outlet flange, with removable feet
03		315 ... 450	with standard outlet flange and removable feet
04		315 ... 630	without outlet flange, with galvanized rectangular frame
05		315 ... 630	with standard outlet flange, with galvanized rectangular frame
06		710 ... 2000	without outlet flange, with welded rectangular frame
07		710 ... 2000	with standard outlet flange with welded rectangular frame

Impellers

The torsion-resistant impellers guarantee a high standard of technology regarding volume flows and processing. The impellers with the shaft are statically and dynamically balanced on precision machines according to quality standard Q 2.5 of VDI 2060, AMCA 204 & ISO 14694. The backward curved impellers of the **HRE** range are made of steel with powder coated or galvanized/stainless steel as option. All impeller series guarantee highest peripheral speed. The aero dynamical design stands for the precision of these modern high efficiency impellers. For chemical resistance applications, both fan casing and impeller can be finished with special epoxy protection coating or fully manufactured in GRP (FRP) material.

Shaped inlets

The aerodynamically shaped inlets are bolted in and guarantee a perfect inlet stream onto the impeller.

Inlets for the type **HRE** are made of steel with powder coated or stainless steel/epoxy painted mild steel material as options.

Shafts

All precision shafts are trued and have a smooth finish. Both shaft ends have as a standard feature diameters complying with DIN 748, sheet 1 and a groove (DIN 6885, sheet 1) with locking spring. A wax coating provides protection against corrosion of this precision engineered shaft.

Bearings

The low noise precision ball bearings are designed for a theoretical life of at least 40.000 working hours. Limiting values for speed and power are indicated on the characteristic curves and should not be exceeded. Long term quality is safeguarded when general assembly and service guidelines for V-belt drives are adhered to.

Fan type code

H R E 05 500

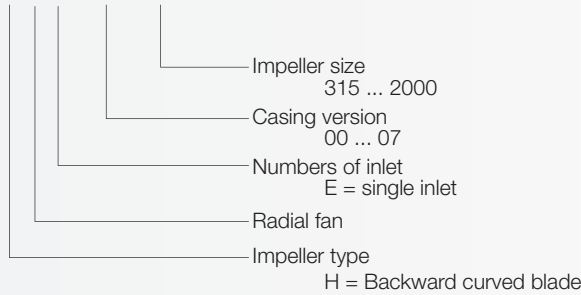

Dongguan Wolter Chemco Ventilation Ltd. certifies that the Series HRE shown herein are licensed to bear the AMCA Seal. The ratings shown are based on tests and procedures performed in accordance with AMCA Publication 211 and AMCA Publication 311 and comply with the requirements of the AMCA Certified Ratings Program.

HRE 315 to 630 of version 00 to 05

The grooved ball bearings in the harmonic strut housings are completely sealed and maintenance free. Unavoidable alignment errors in the sheet metal casing are compensated by the spherical outer ring. The insulating rubber rings absorbing vibration and structure-born noise are temperature and chemical resistant and electrical conductors. The rugged sealing rings and the inner rings of the bearings are galvanized. The flexible bearing cage is made from polyamide.

The bearing is attached to the shaft by means of an eccentric tension ring. In order to guarantee the bearing seat is free from play and to avoid corrosion of the tension ring it is sealed with a liquid synthetic.

HRE 710 to 2000 of version 06 to 07

The grooved ball bearings in the rugged cast-iron casings are completely sealed and maintenance free. Unavoidable alignment errors are compensated by the spherical outer ring. The one-piece bearing housing conforms to DIN 626 Part 213 (ISO 3228) and allows full utilization of the carrying capacity of the mounted regulating bearing.

All housings are equipped with lubricating bore holes for the possibility of secondary lubrication. As protection the lubricating bore holes are closed with a synthetic stopper.

For corrosion reasons the rugged sealing rings and the bearing inner ring are galvanized. The flexible bearing cage is made of polyamide.

The bearing is attached to the shaft by means of an eccentric tension ring. In order to guarantee the bearing fit is free from play and to avoid corrosion of the tension ring it is sealed with a liquid synthetic.

Sound levels

In order to make possible an assessment of sound projection adequate to the human ear the A-assessed description of sound levels has been chosen. The ascertaining of the sound power level follows the reverberant room method according to AMCA 300.

The sound power levels shown on each performance curve, L_{wiA}, refer to the overall sound power "A-Weighted" levels. The computed sound power levels were converted into A-Weighted levels using adjustments to the octave band spectrum as follows:

Centre Frequency Hz	63	125	250	500	1000	2000	4000	8000
A-Weighted Adjustment dB(A)	-26.2	-16.1	-8.6	-3.2	0	+1.2	+1.0	-1.1

The overall sound pressure levels, L_{piA}, can be calculated from the overall sound power levels as follows:

1) Free Field Conditions: L_{piA} = L_{wiA} - (20 log₁₀ d) - 11

2) Room Conditions: L_{piA} = L_{wiA} - (20 log₁₀ d) - 7

Where: d = distance from fan in meters.

Performance curves

The performance curves have been established using the outlet test method in the test chamber according to AMCA 210 installation B (free inlet, ducted outlet).

The curves indicate as a function of the volume flow:

- the total pressure increase Δp_{tot} for constant speed (heavy black lines)
- constant lines of shaft power P_w (red Lines)
- constant lines of sound power level L_{wiA} (blue lines)

All values relate to an air density:

$\rho_1 = 1,2 \text{ kg/m}^3 \text{ at } 20^\circ\text{C}$

The dynamic pressure p_{d2} and the flow speed c_2 respectively stated in the diagrams refer to the flange cross section of the outlet connection pieces.

Motor power

The powers (P_w) provided on the performance curve are the internal powers required by the ventilator and do not include the mechanical losses. To compute the total required shaft input power, the internal power must be divided by the mechanical efficiency:

$$P_s = P_w / \eta_m$$

where: P_s = total required shaft input power

η_m = mechanical efficiency

The mechanical efficiency is provided as follow:

Way of ventilator driving	η_m
Electric motor directly driven	1
Coupling directly driven	0,98
V-belt driven	0,95

The performance curves provided in this catalogue were measured according to AMCA 210 (ISO 5801) in a test chamber.
The sketch below shows the principle set up of the test chamber.

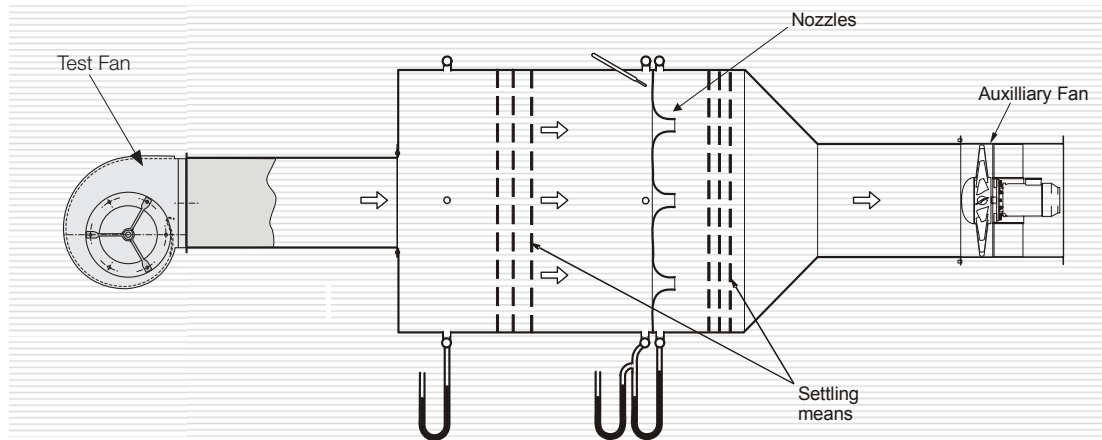

AMCA 210 Figure 12
ISO 5801 Figure 73b

AMCA - FEG rating

Fan Efficiency Grade: HRE



Certified FEGs are determined in accordance with AMCA 205 Energy Efficiency Classification for fans. In conjunction with AMCA 211 Certified Ratings Program, Product Rating Manual for Fan Air Performance. This classification is based on total peak, or optimum, fan efficiency for a given fan speed, impeller diameter and test application category (test configuration). For the purpose of energy classification, the peak efficiency shall be determined at a speed that is lower than the fan's maximum design speed.

The AMCA Certified Ratings Seal applies to the Fan Efficiency Grade (FEG) for HRE series Centrifugal Fan model HRE 315 to HRE 2000 as shown in the table below.

Fan Model No.	Max. Fan Speed (rpm)	Fan Outlet Area (m2)	Fan Efficiency Grade (FEG)	Fan Model No.	Max. Fan Speed (rpm)	Fan Outlet Area (m2)	Fan Efficiency Grade (FEG)
HRE 315	4000	0.0901	85	HRE 900	1400	0.6724	80
HRE 355	3800	0.1119	85	HRE 1000	1300	0.8413	80
HRE 400	3200	0.1399	80	HRE 1120	1300	1.0535	80
HRE 450	2800	0.1764	80	HRE 1250	1200	1.3019	80
HRE 500	2800	0.2195	85	HRE 1400	1000	1.6359	80
HRE 560	2600	0.2738	85	HRE 1600	900	2.1493	80
HRE 630	2200	0.3460	85	HRE 1800	800	2.7127	80
HRE 710	2000	0.4292	80	HRE 2000	750	3.3289	80
HRE 800	1600	0.5367	80				

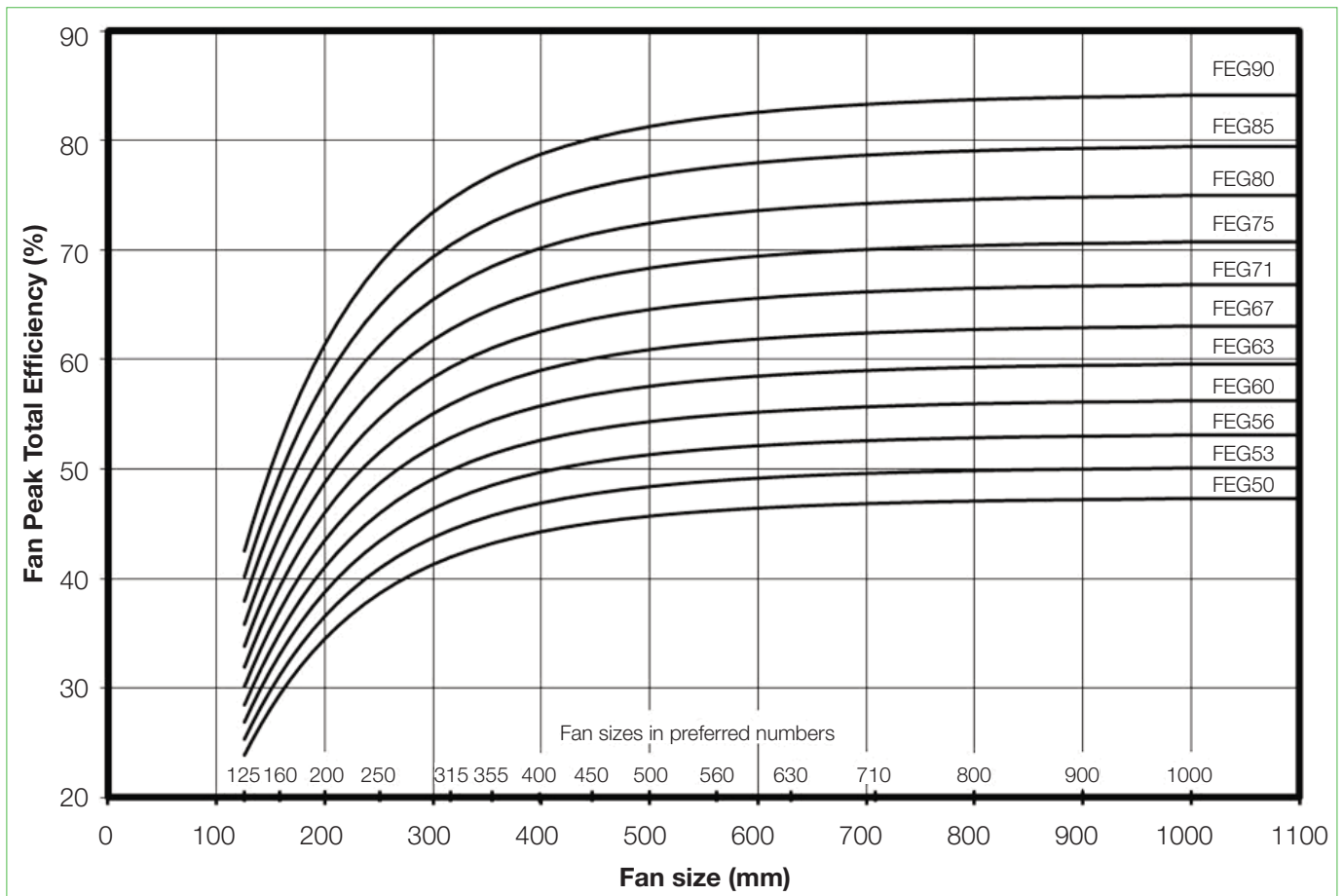



Performance Curve

HRE 315



Fan test laboratory AMCA 210 Fig.12, 140000 CMH Test Chamber. Performance certified is for installation type B-Free inlet, Ducted outlet.

Power rating (kW) does not include transmission losses, Performance ratings do not include the effects of apertures (accessories). The A-weighted sound ratings shown have been calculated per AMCA International Standard 301. Values shown are for inlet LwA sound power levels for installation Type B: free inlet, ducted outlet.

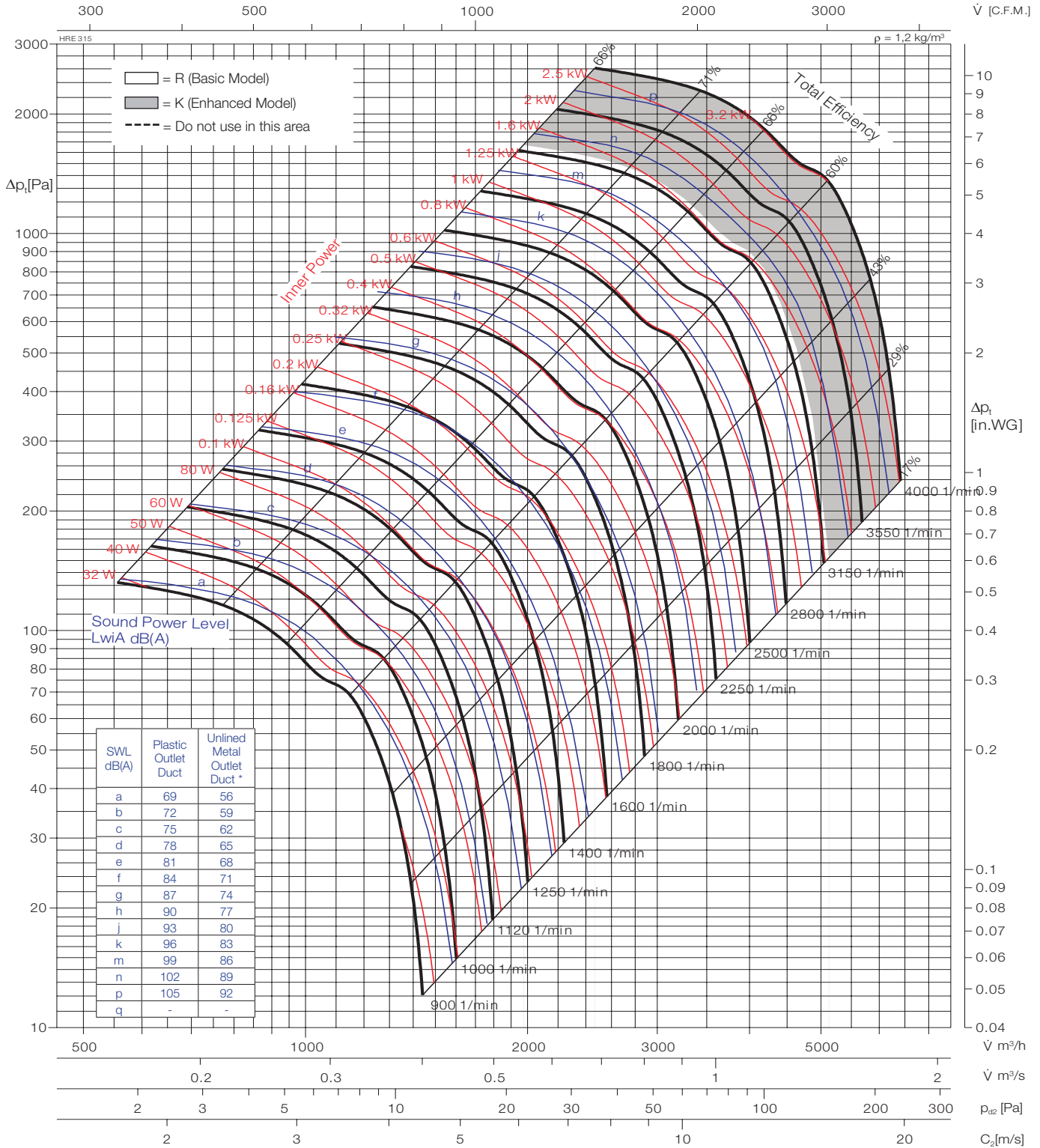

Typ	Art.Nr.	█ [kg]	Typ	Art.Nr.	█ [kg]
HRE 03 315	-	27			
HRE 05 315	-	39			

Wheel diameter	D = 319 mm
Number of blades	z = 8
Moment of inertia	J = 0,2759 kgm ²
Wheel weight	G = 3,9 kg
Speed limit	n_{max} = 4000 1/min

* Sound power level with unlined metal outlet duct were obtained from the test in the reverberant room. Data are not licensed by AMCA.



Performance Curve

HRE 355



Fan test laboratory AMCA 210 Fig.12, 140000 CMH Test Chamber. Performance certified is for installation type B-Free inlet, Ducted outlet.

Power rating (kW) does not include transmission losses, Performance ratings do not include the effects of appurtenances (accessories). The A-weighted sound ratings shown have been calculated per AMCA International Standard 301. Values shown are for LwA sound power levels for installation Type B: free inlet, ducted outlet.

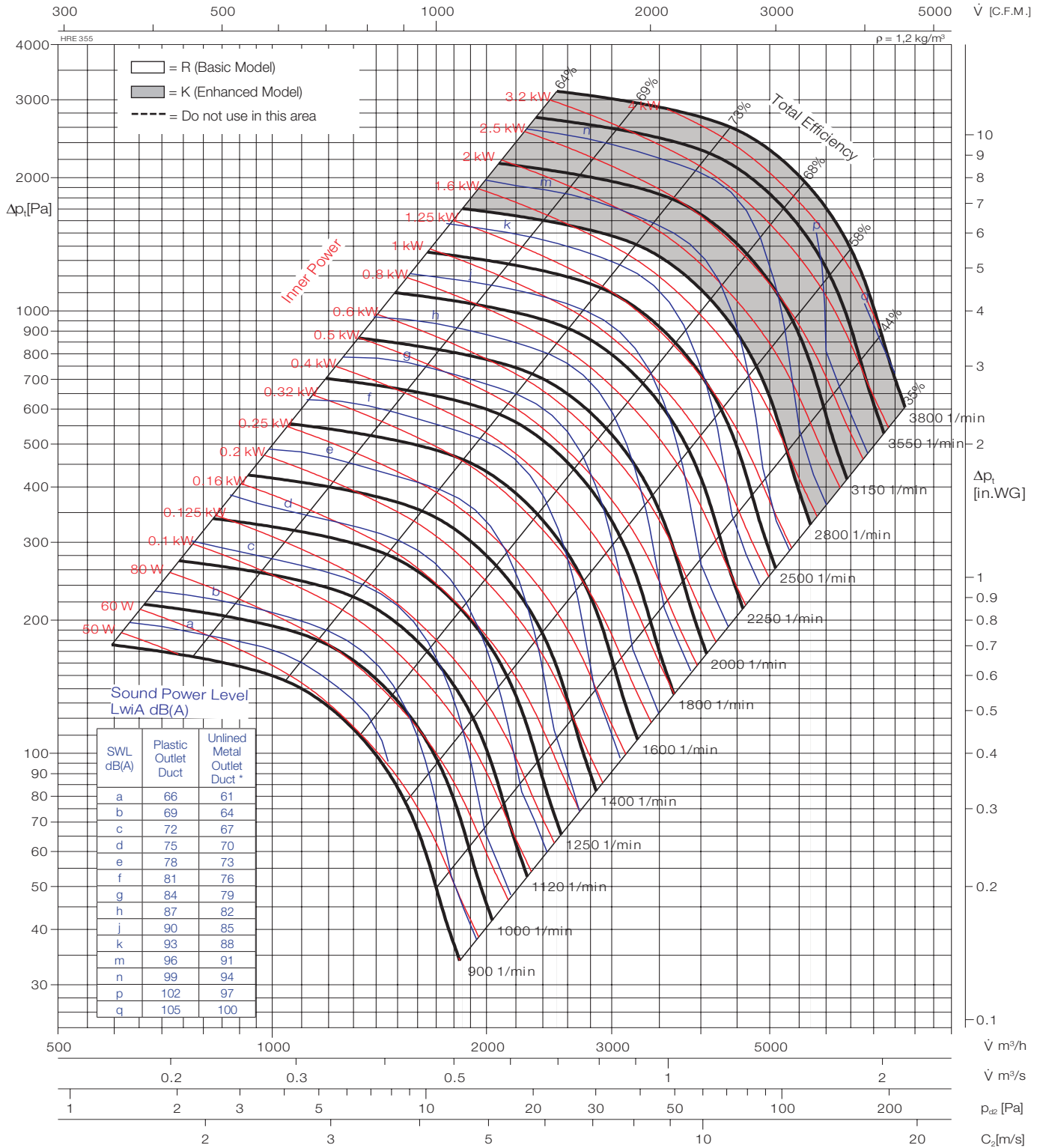

Typ	Art.Nr.	█ [kg]	Typ	Art.Nr.	█ [kg]
HRE 03 355	-	38			
HRE 05 355	-	51			

Wheel diameter	D = 359 mm
Number of blades	z = 8
Moment of inertia	J = 0,4343 kgm ²
Wheel weight	G = 4,8 kg
Speed limit	n_{max} = 3800 1/min

* Sound power level with unlined metal outlet duct were obtained from the test in the reverberant room. Data are not licensed by AMCA.



Performance Curve

HRE 400



Fan test laboratory AMCA 210 Fig.12, 140000 CMH Test Chamber. Performance certified is for installation type B-Free inlet, Ducted outlet.

Power rating (kW) does not include transmission losses, Performance ratings do not include the effects of apertures (accessories). The A-weighted sound shown have been calculated per AMCA International Standard 301. Values shown are for inlet LwA sound power levels for installation Type B: free inlet, ducted outlet.

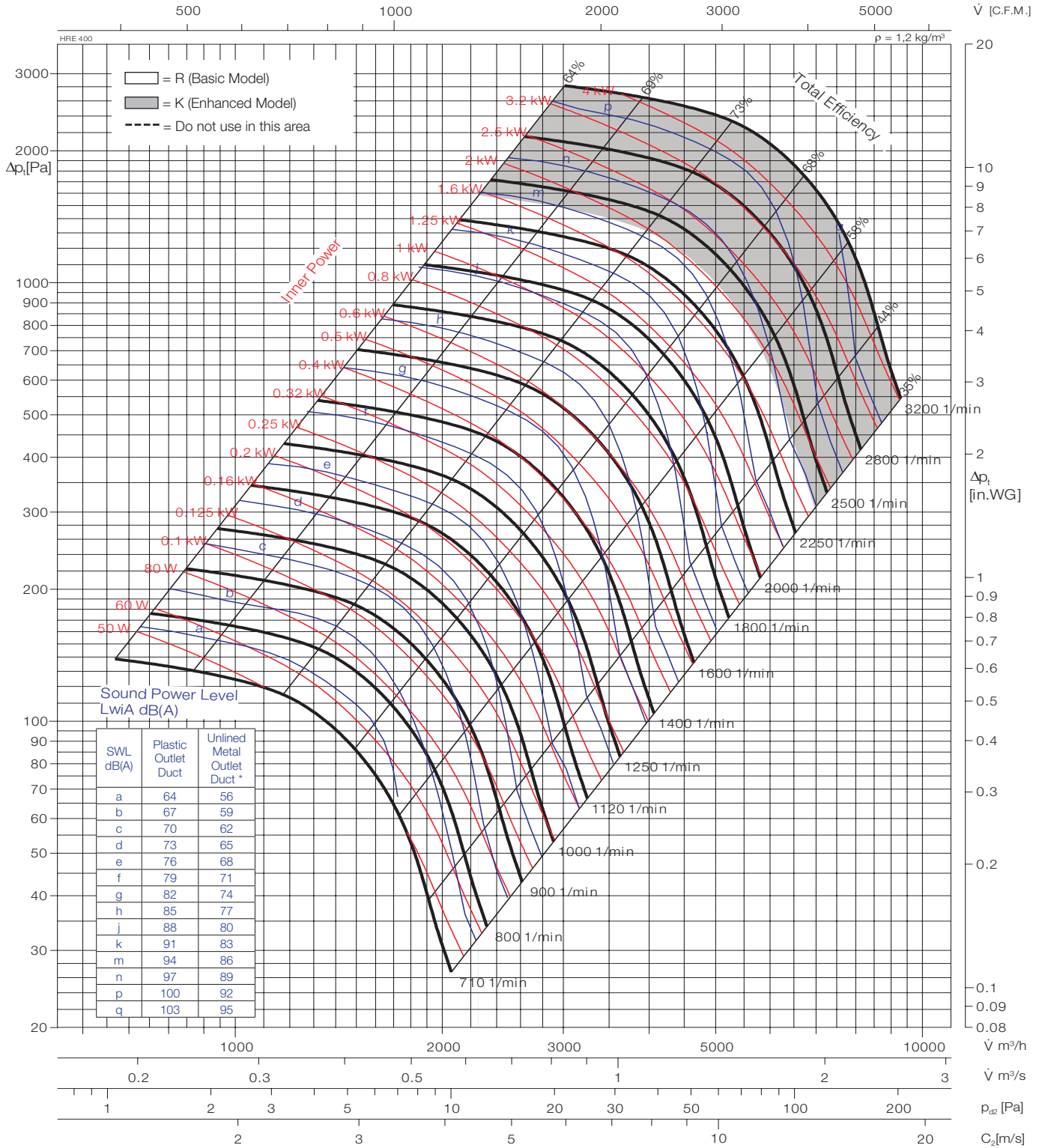

Typ	Art.Nr.	█ [kg]	Typ	Art.Nr.	█ [kg]
HRE 03 400	-	43			
HRE 05 400	-	57			

Wheel diameter	D = 404 mm
Number of blades	z = 8
Moment of inertia	J = 0,820 kgm ²
Wheel weight	G = 7,2 kg
Speed limit	n_{max} = 3200 1/min

* Sound power level with unlined metal outlet duct were obtained from the test in the reverberant room. Data are not licensed by AMCA.



Performance Curve

HRE 450



Fan test laboratory AMCA 210 Fig.12, 140000 CMH Test Chamber. Performance certified is for installation type B-Free inlet, Ducted outlet.

Power rating (kW) does not include transmission losses, Performance ratings do not include the effects of appurtenances (accessories). The A-weighted sound ratings shown have been calculated per AMCA International Standard 301. Values shown are for inlet LwA sound power levels for installation Type B: free inlet, ducted outlet.

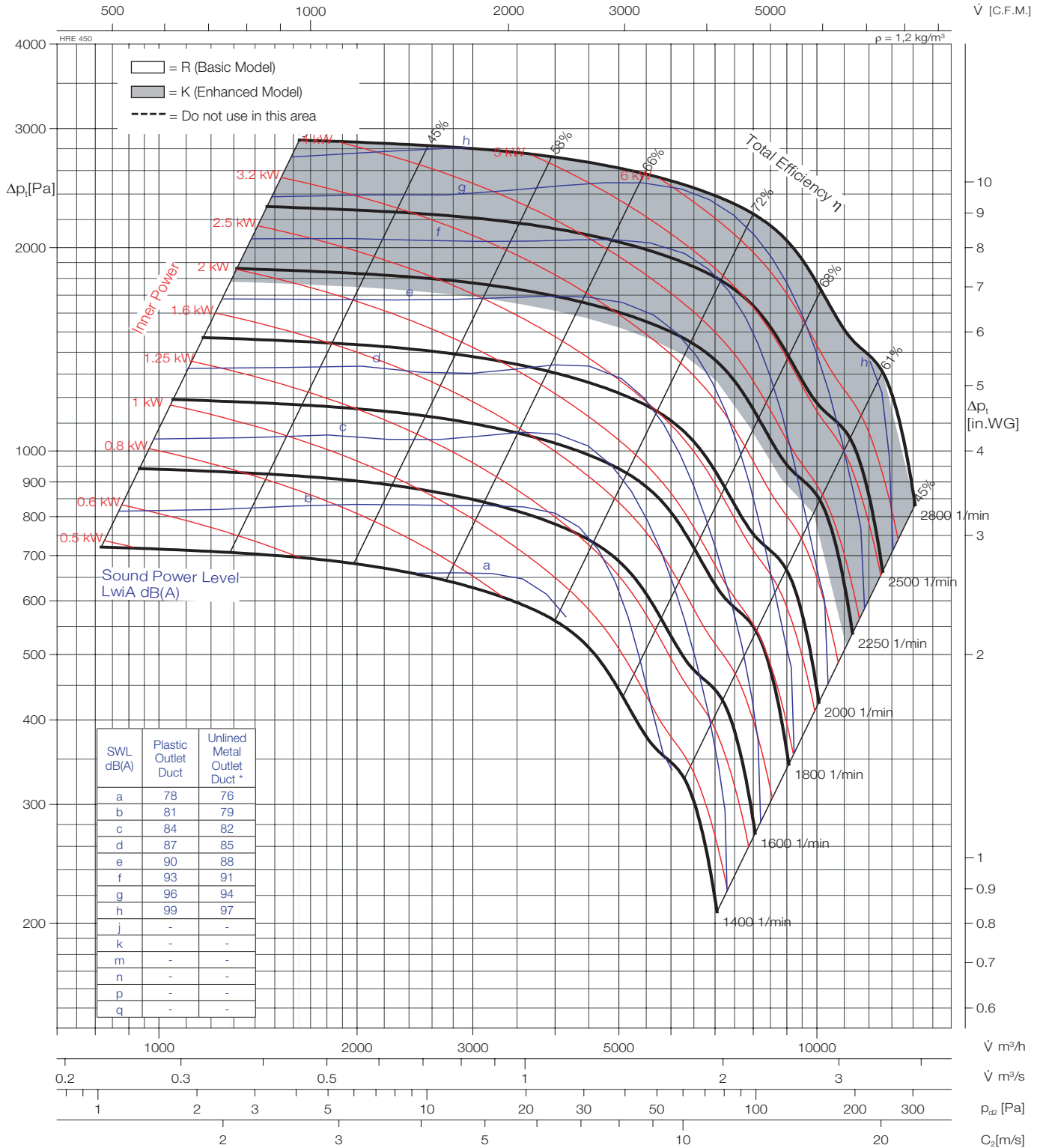

Typ	Art.Nr.	W [kg]	Typ	Art.Nr.	W [kg]
HRE 05 450	-	54			
HRE 07 450	-	72			

Wheel diameter	D = 454 mm
Number of blades	z = 8
Moment of inertia	J = 1,425 kgm ²
Wheel weight	G = 9,9 kg
Speed limit	n_{max} = 2800 1/min

* Sound power level with unlined metal outlet duct were obtained from the test in the reverberant room. Data are not licensed by AMCA.



Performance Curve

HRE 500



Fan test laboratory AMCA 210 Fig.12, 140000 CMH Test Chamber. Performance certified is for installation type B-Free inlet, Ducted outlet.

Power rating (kW) does not include transmission losses, Performance ratings do not include the effects of apertures (accessories). The A-weighted sound ratings shown have been calculated per AMCA International Standard 301. Values shown are for inlet LwA sound power levels for installation Type B: free inlet, ducted outlet.

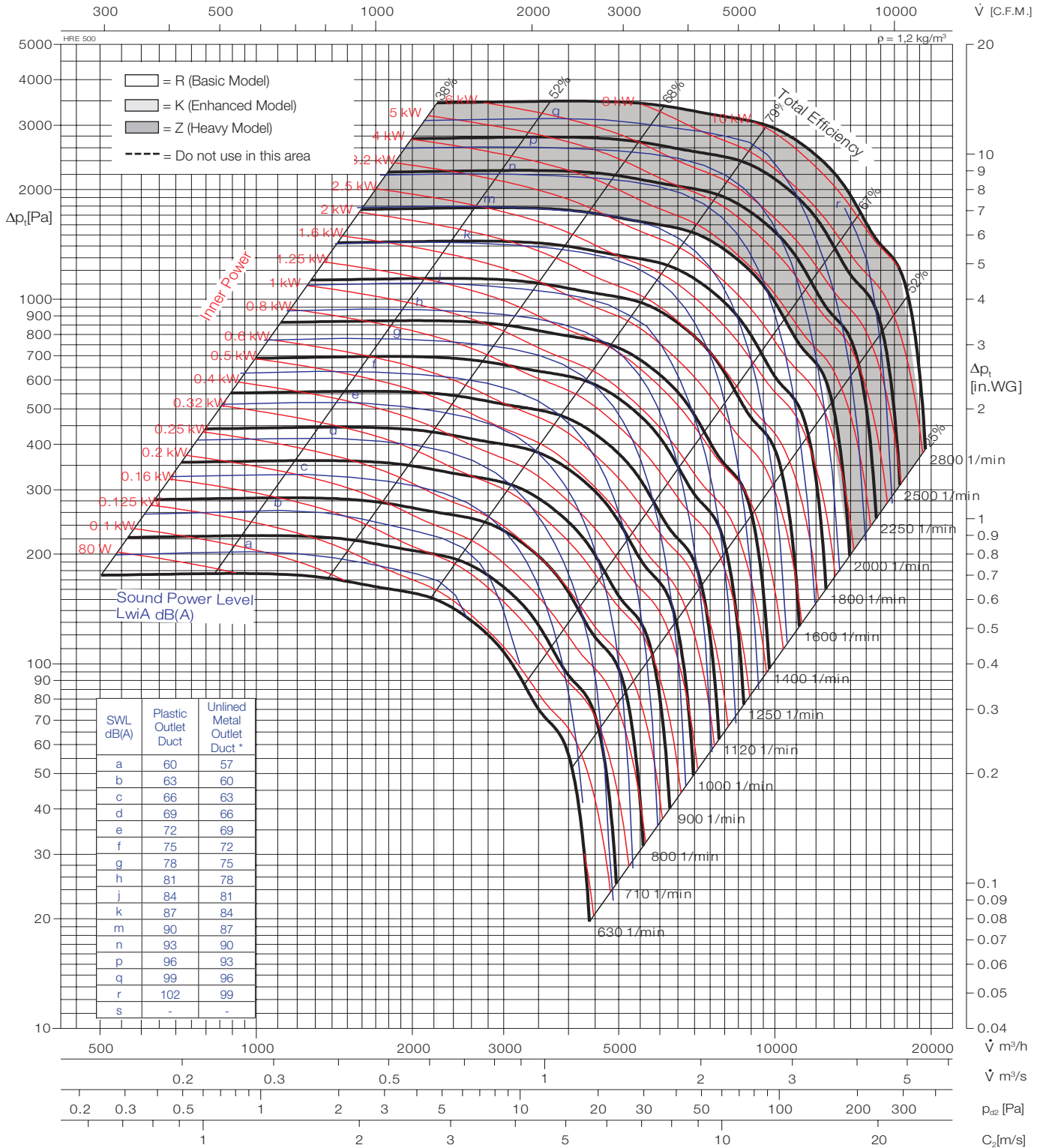

Typ	Art.Nr.	█ [kg]	Typ	Art.Nr.	█ [kg]
HRE 05 500	-	69			
HRE 07 500	-	90			

Wheel diameter	D = 510 mm
Number of blades	z = 8
Moment of inertia	J = 2,394 kgm ²
Wheel weight	G = 13,2 kg
Speed limit	n_{max} = 2800 1/min

* Sound power level with unlined metal outlet duct were obtained from the test in the reverberant room. Data are not licensed by AMCA.



Performance Curve

HRE 560



Fan test laboratory AMCA 210 Fig.12, 140000 CMH Test Chamber. Performance certified is for installation type B-Free inlet, Ducted outlet.

Power rating (kW) does not include transmission losses, Performance ratings do not include the effects of appurtenances (accessories). The A-weighted sound ratings shown have been calculated per AMCA International Standard 301. Values shown are for LwiA sound power levels for installation Type B: free inlet, ducted outlet.

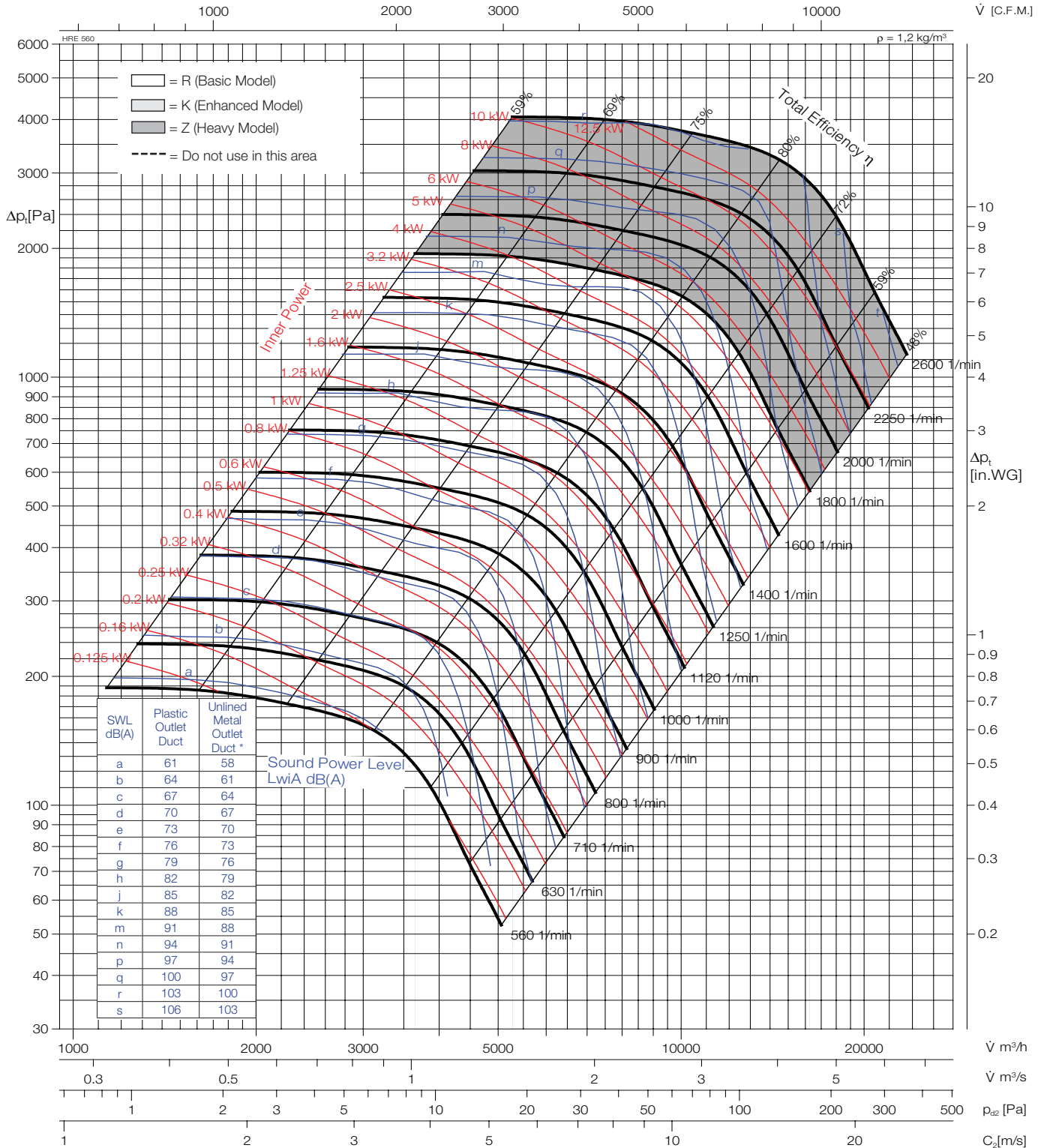

Typ	Art.Nr.	█ [kg]	Typ	Art.Nr.	█ [kg]
HRE 05 560	-	108			
HRE 07 560	-	138			

Wheel diameter	D = 570 mm
Number of blades	z = 8
Moment of inertia	J = 4,50 kgm ²
Wheel weight	G = 19,8 kg
Speed limit	n_{max} = 2600 1/min

* Sound power level with unlined metal outlet duct were obtained from the test in the reverberant room. Data are not licensed by AMCA.



Performance Curve

HRE 630



Fan test laboratory AMCA 210 Fig.12, 140000 CMH Test Chamber. Performance certified is for installation type B-Free inlet, Ducted outlet.

Power rating (kW) does not include transmission losses, Performance ratings do not include the effects of apertures (accessories). The A-weighted sound shown have been calculated per AMCA International Standard 301. Values shown are for inlet LwA sound power levels for installation Type B: free inlet, ducted outlet.

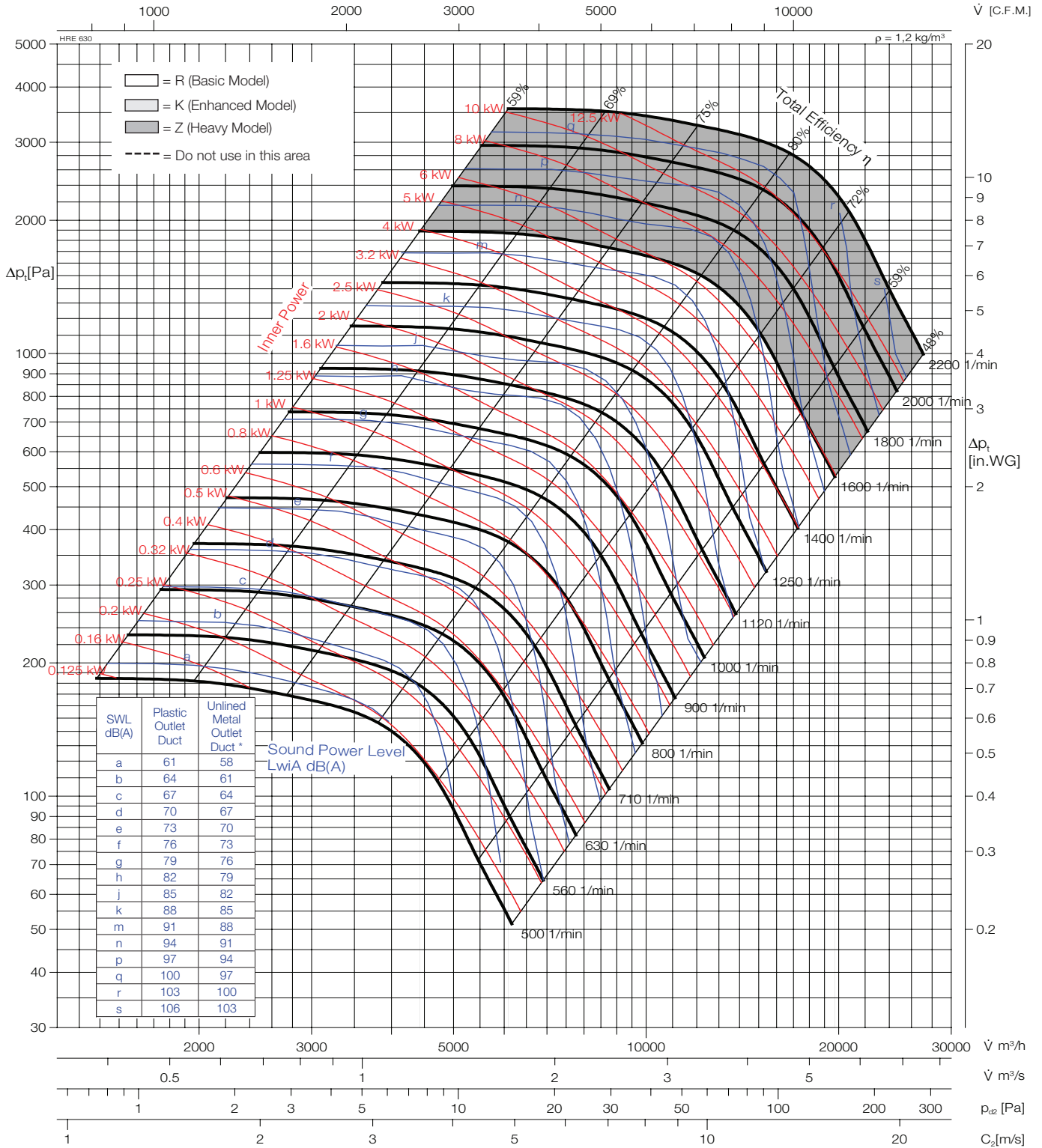

Typ	Art.Nr.	█ [kg]	Typ	Art.Nr.	█ [kg]
HRE 05 630	-	122			
HRE 07 630	-	157			

Wheel diameter	D = 640 mm
Number of blades	z = 8
Moment of inertia	J = 7,60 kgm ²
Wheel weight	G = 26,6 kg
Speed limit	n_{max} = 2200 1/min

* Sound power level with unlined metal outlet duct were obtained from the test in the reverberant room. Data are not licensed by AMCA.



Performance Curve

HRE 710



Fan test laboratory AMCA 210 Fig.12, 140000 CMH Test Chamber. Performance certified is for installation type B-Free inlet, Ducted outlet.

Power rating (kW) does not include transmission losses, Performance ratings do not include the effects of appurtenances (accessories). The A-weighted sound ratings shown have been calculated per AMCA International Standard 301. Values shown are for inlet LwiA sound power levels for installation Type B: free inlet, ducted outlet.

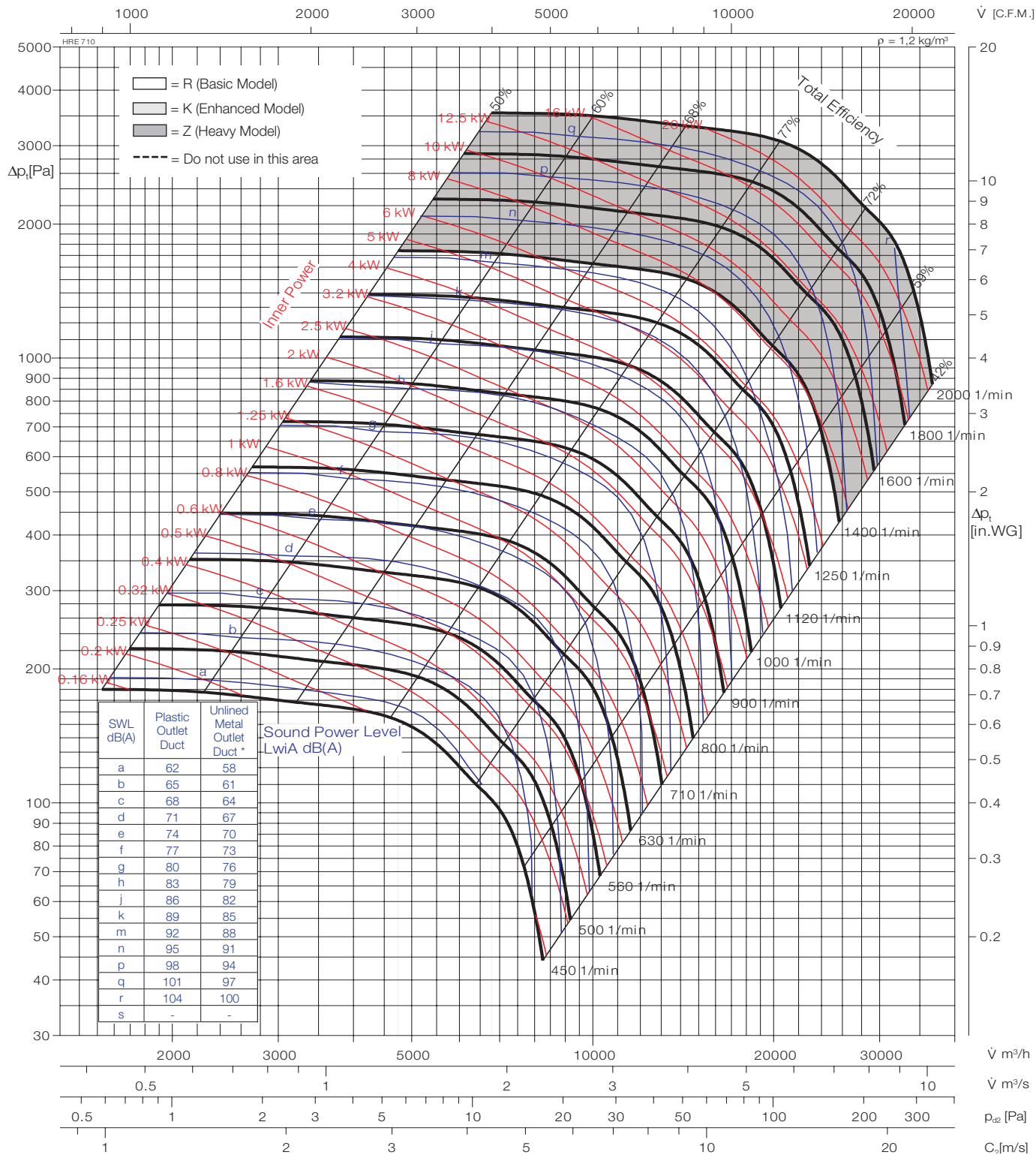

Typ	Art.Nr.	█ [kg]	Typ	Art.Nr.	█ [kg]
HRE 07 710	-	207			

Wheel diameter	D = 720 mm
Number of blades	z = 8
Moment of inertia	J = 12,02 kgm ²
Wheel weight	G = 33,3 kg
Speed limit	n_{max} = 2000 1/min

* Sound power level with unlined metal outlet duct were obtained from the test in the reverberant room. Data are not licensed by AMCA.



Performance Curve

HRE 800



Fan test laboratory AMCA 210 Fig.12, 140000 CMH Test Chamber. Performance certified is for installation type B-Free inlet, Ducted outlet.

Power rating (kW) does not include transmission losses, Performance ratings do not include the effects of apertures (accessories). The A-weighted sound ratings shown have been calculated per AMCA International Standard 301. Values shown are for inlet LwiA sound power levels for installation Type B: free inlet, ducted outlet.

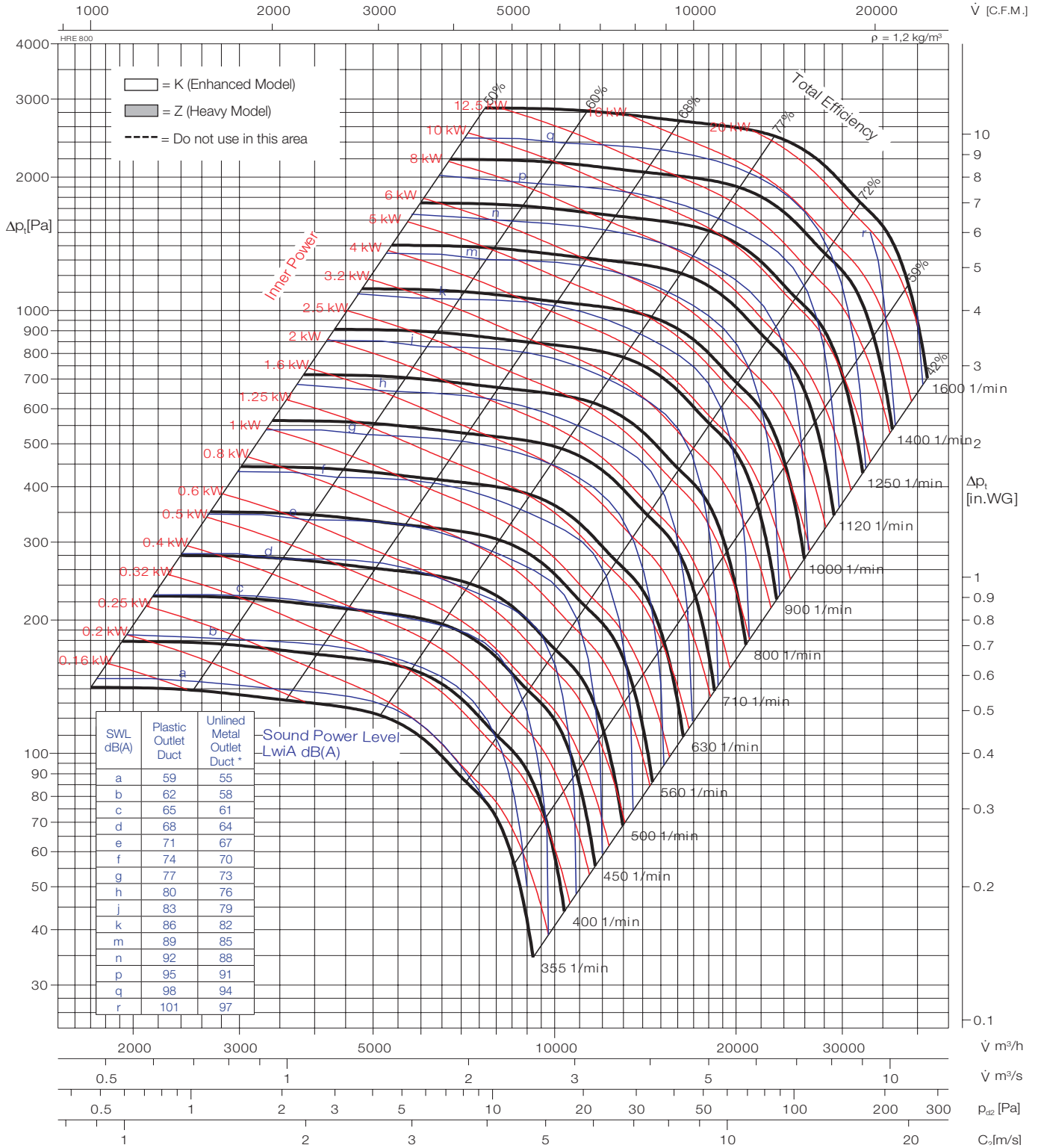

Typ	Art.Nr.	█ [kg]	Typ	Art.Nr.	█ [kg]
HRE 07 800	-	240			

Wheel diameter	D = 808 mm
Number of blades	z = 8
Moment of inertia	J = 19,47 kgm ²
Wheel weight	G = 42,8 kg
Speed limit	n_{max} = 1600 1/min

* Sound power level with unlined metal outlet duct were obtained from the test in the reverberant room. Data are not licensed by AMCA.



Performance Curve

HRE 900



Fan test laboratory AMCA 210 Fig.12, 140000 CMH Test Chamber. Performance certified is for installation type B-Free inlet, Ducted outlet.

Power rating (kW) does not include transmission losses, Performance ratings do not include the effects of appurtenances (accessories). The A-weighted sound ratings shown have been calculated per AMCA International Standard 301. Values shown are for inlet LwiA sound power levels for installation Type B: free inlet, ducted outlet.

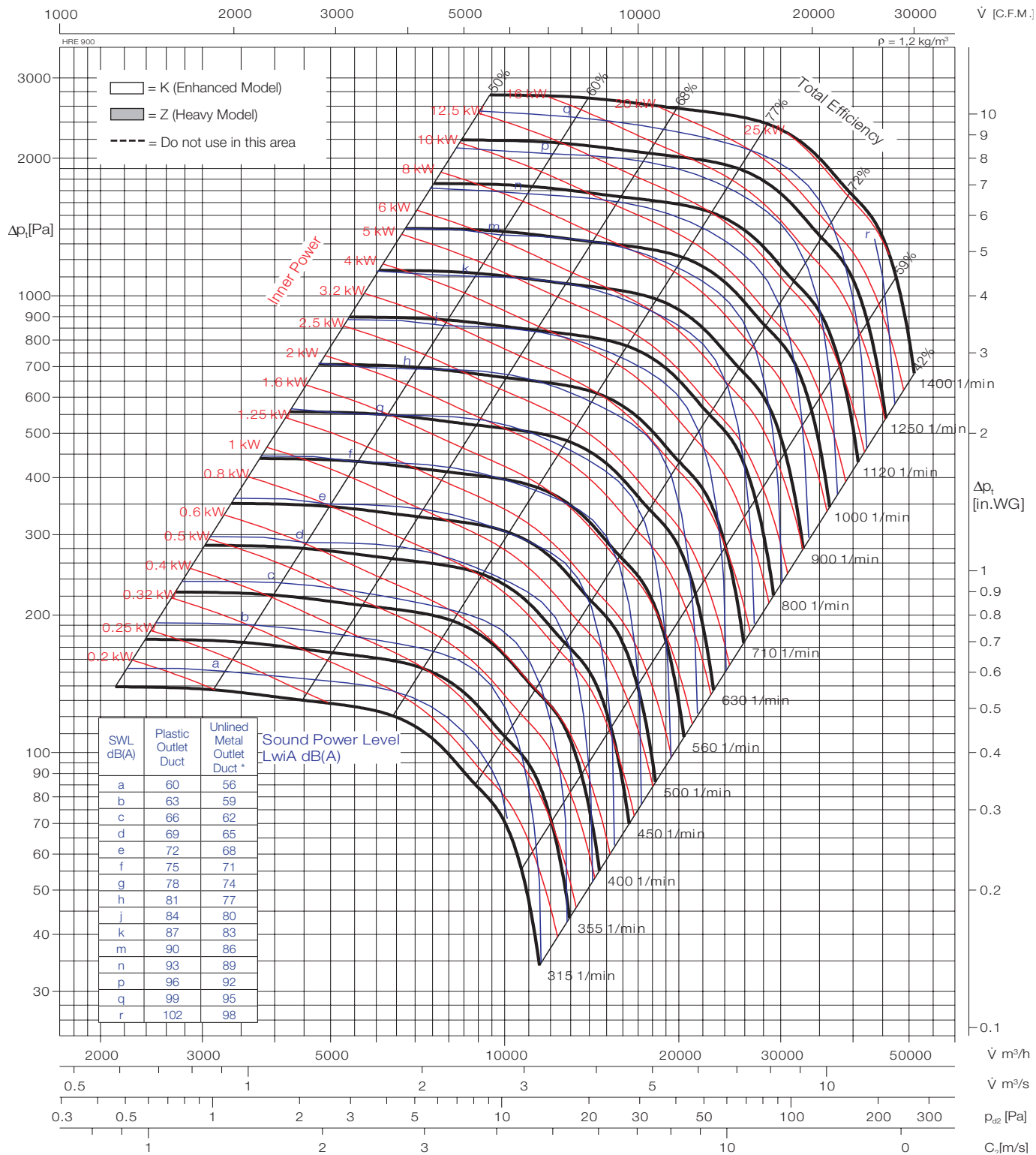

Typ	Art.Nr.	█ [kg]	Typ	Art.Nr.	█ [kg]
HRE 07 900	-	344			

Wheel diameter	D = 905 mm
Number of blades	z = 8
Moment of inertia	J = 33,72 kgm ²
Wheel weight	G = 59 kg
Speed limit	n_{max} = 1400 1/min

* Sound power level with unlined metal outlet duct were obtained from the test in the reverberant room. Data are not licensed by AMCA.



Performance Curve

HRE 1000



Fan test laboratory AMCA 210 Fig.12, 140000 CMH Test Chamber. Performance certified is for installation type B-Free inlet, Ducted outlet.

Power rating (kW) does not include transmission losses, Performance ratings do not include the effects of apertures (accessories). The A-weighted sound ratings shown have been calculated per AMCA International Standard 301. Values shown are for inlet LwA sound power levels for installation Type B: free inlet, ducted outlet.

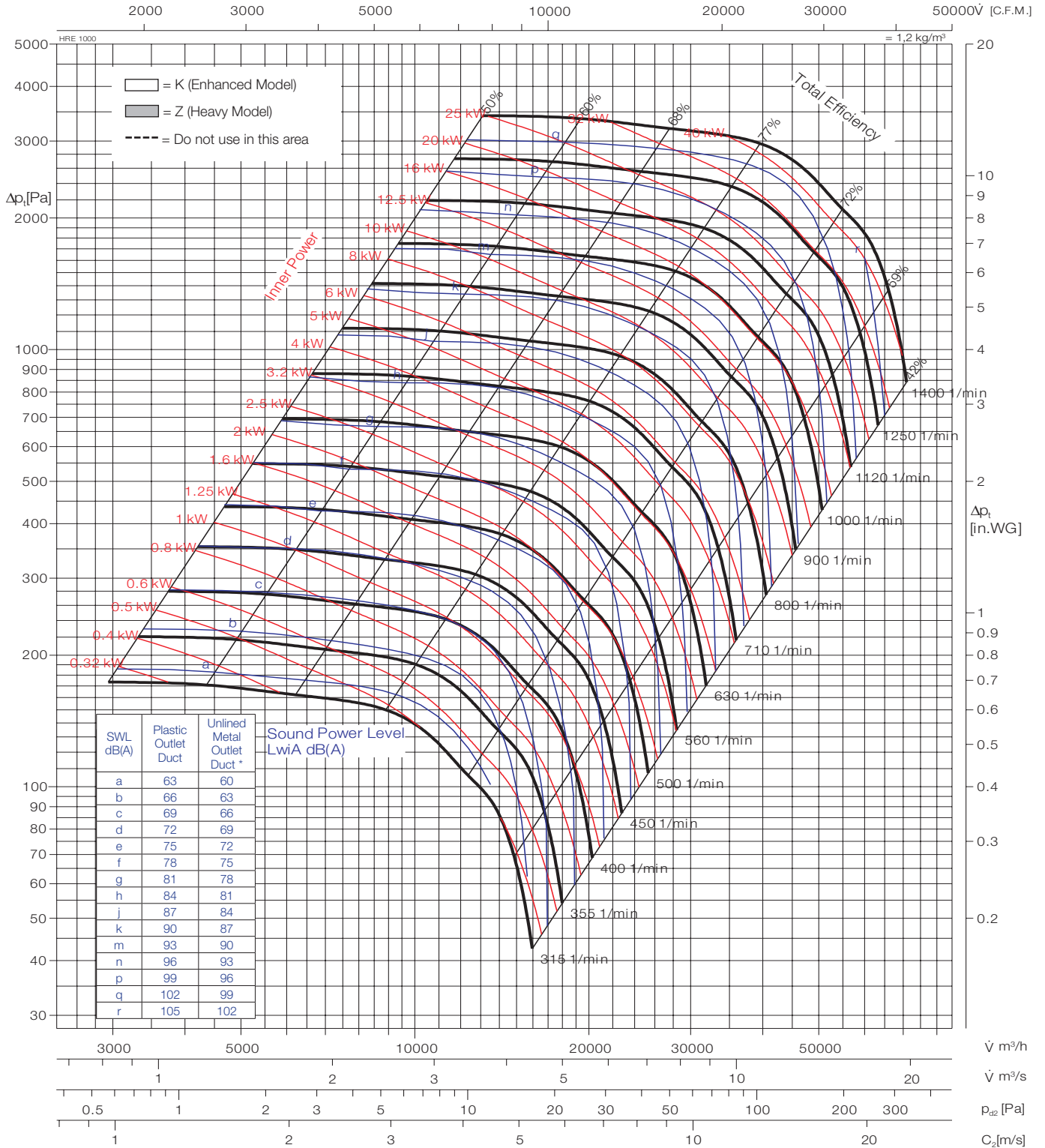

Typ	Art.Nr.	█ [kg]	Typ	Art.Nr.	█ [kg]
HRE 07 1000	-	427			

Wheel diameter	D = 1010 mm
Number of blades	z = 8
Moment of inertia	J = 53,72 kgm ²
Wheel weight	G = 75,2 kg
Speed limit	n_{max} = 1300 1/min

* Sound power level with unlined metal outlet duct were obtained from the test in the reverberant room. Data are not licensed by AMCA.



Performance Curve

HRE 1120



Fan test laboratory AMCA 210 Fig.12, 140000 CMH Test Chamber. Performance certified is for installation type B-Free inlet, Ducted outlet.

Power rating (kW) does not include transmission losses, Performance ratings do not include the effects of appurtenances (accessories). The A-weighted sound ratings shown have been calculated per AMCA International Standard 301. Values shown are for inlet LwiA sound power levels for installation Type B: free inlet, ducted outlet.

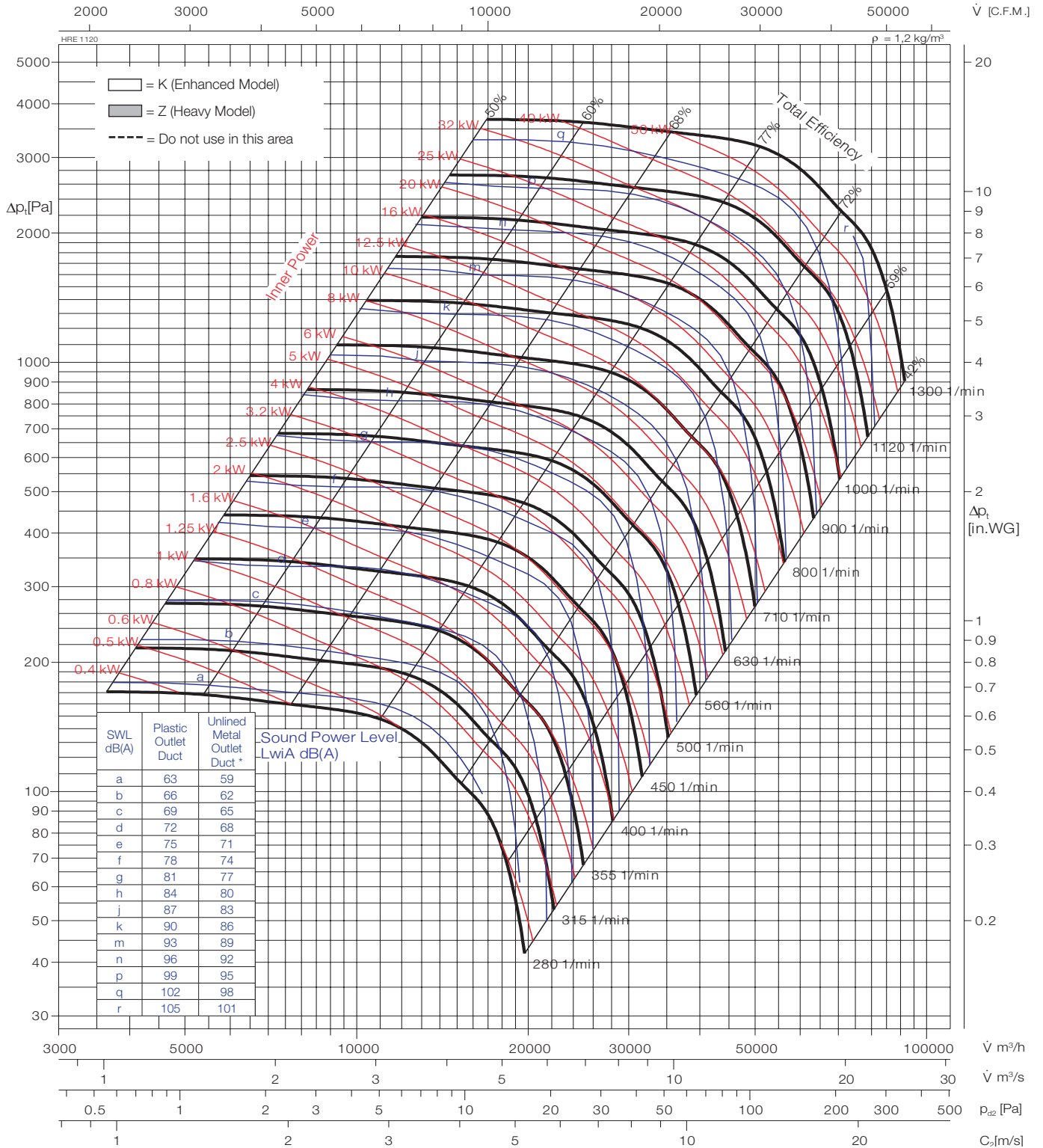

Typ	Art.Nr.	W [kg]	Typ	Art.Nr.	W [kg]
HRE 07 1120	-	656			

Wheel diameter	D = 1127 mm
Number of blades	z = 8
Moment of inertia	J = 85,97 kgm ²
Wheel weight	G = 96,8 kg
Speed limit	n_{max} = 1300 1/min

* Sound power level with unlined metal outlet duct were obtained from the test in the reverberant room. Data are not licensed by AMCA.



Performance Curve

HRE 1250



Fan test laboratory AMCA 210 Fig.12, 140000 CMH Test Chamber. Performance certified is for installation type B-Free inlet, Ducted outlet.

Power rating (kW) does not include transmission losses, Performance ratings do not include the effects of apertures (accessories). The A-weighted sound shown have been calculated per AMCA International Standard 301. Values shown are for inlet LwA sound power levels for installation Type B: free inlet, ducted outlet.

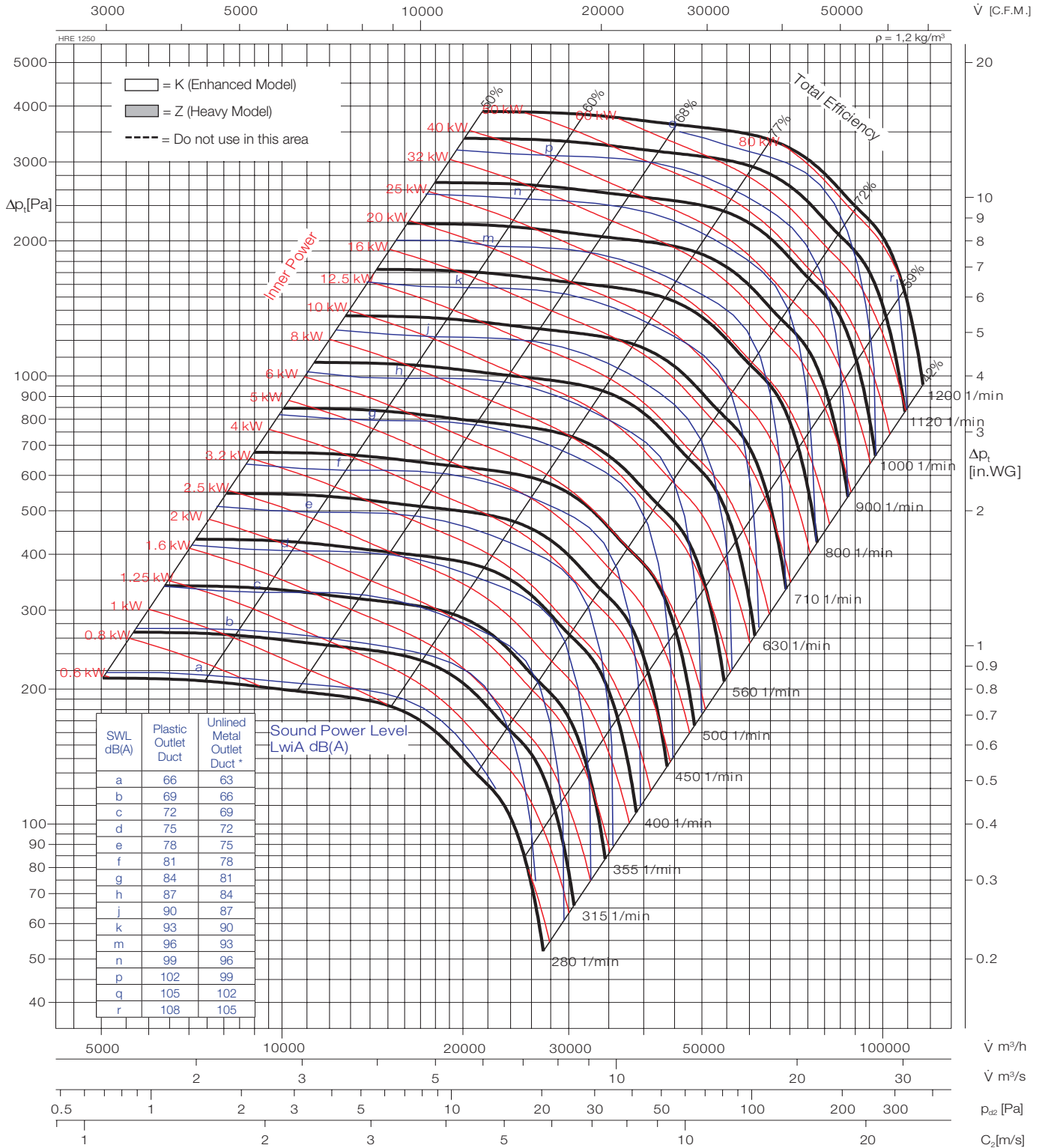

Typ	Art.Nr.	█ [kg]	Typ	Art.Nr.	█ [kg]
HRE 07 1250	-	865			

Wheel diameter	D = 1255 mm
Number of blades	z = 8
Moment of inertia	J = 137,1 kgm ²
Wheel weight	G = 124 kg
Speed limit	n_{max} = 1200 1/min

* Sound power level with unlined metal outlet duct were obtained from the test in the reverberant room. Data are not licensed by AMCA.



Performance Curve

HRE 1400



Fan test laboratory AMCA 210 Fig.12, 140000 CMH Test Chamber. Performance certified is for installation type B-Free inlet, Ducted outlet.

Power rating (kW) does not include transmission losses, Performance ratings do not include the effects of appurtenances (accessories). The A-weighted sound ratings shown have been calculated per AMCA International Standard 301. Values shown are for inlet LwiA sound power levels for installation Type B: free inlet, ducted outlet.

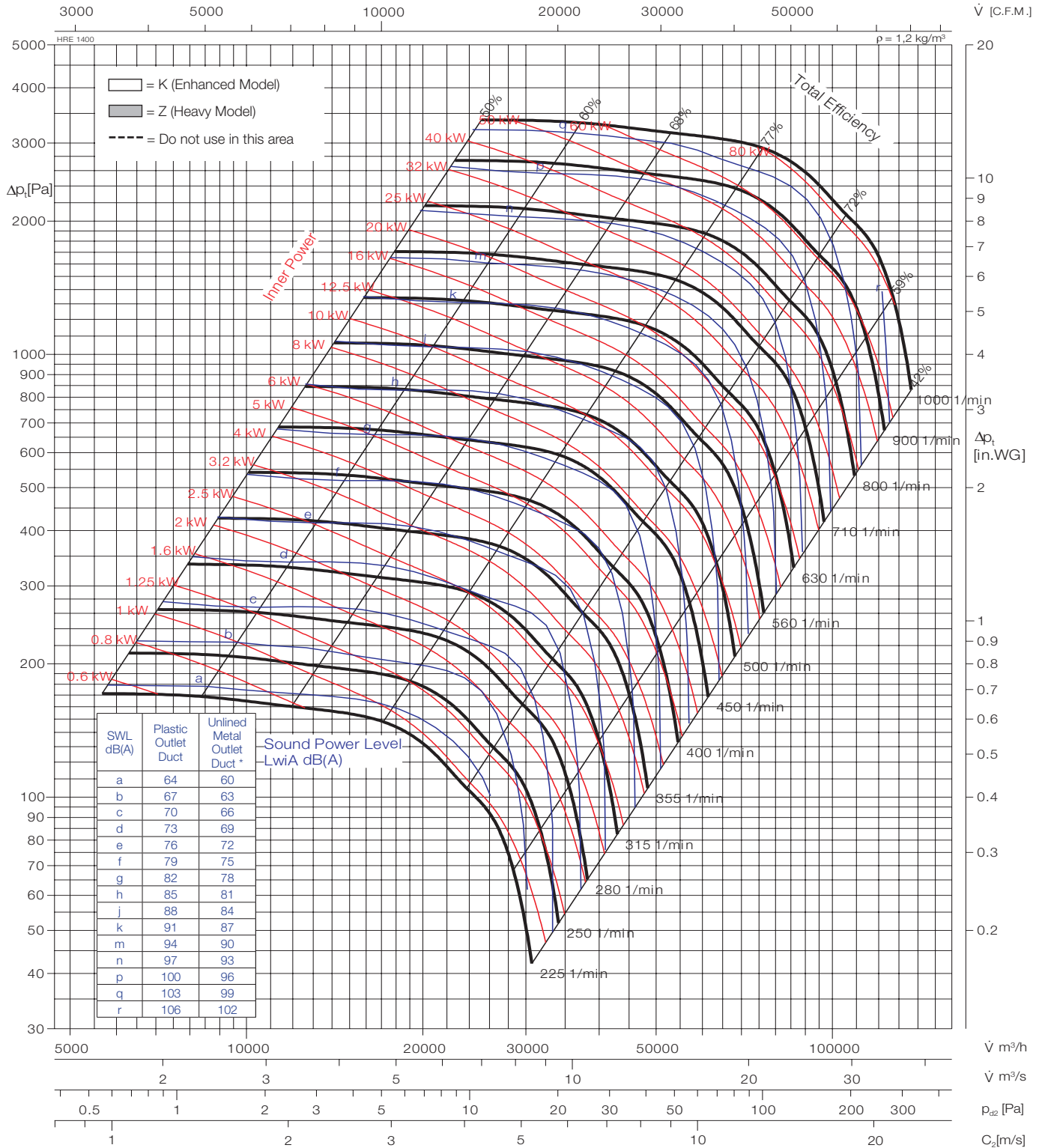

Typ	Art.Nr.	W [kg]	Typ	Art.Nr.	W [kg]
HRE 07 1400	-	1015			

Wheel diameter	D = 1405 mm
Number of blades	z = 8
Moment of inertia	J = 220,9 kgm ²
Wheel weight	G = 160 kg
Speed limit	n_{max} = 1000 1/min

* Sound power level with unlined metal outlet duct were obtained from the test in the reverberant room. Data are not licensed by AMCA.



Performance Curve

HRE 1600



Fan test laboratory AMCA 210 Fig.12, 140000 CMH Test Chamber. Performance certified is for installation type B-Free inlet, Ducted outlet.

Power rating (kW) does not include transmission losses, Performance ratings do not include the effects of apertures (accessories). The A-weighted sound ratings shown have been calculated per AMCA International Standard 301. Values shown are for inlet LwA sound power levels for installation Type B: free inlet, ducted outlet.

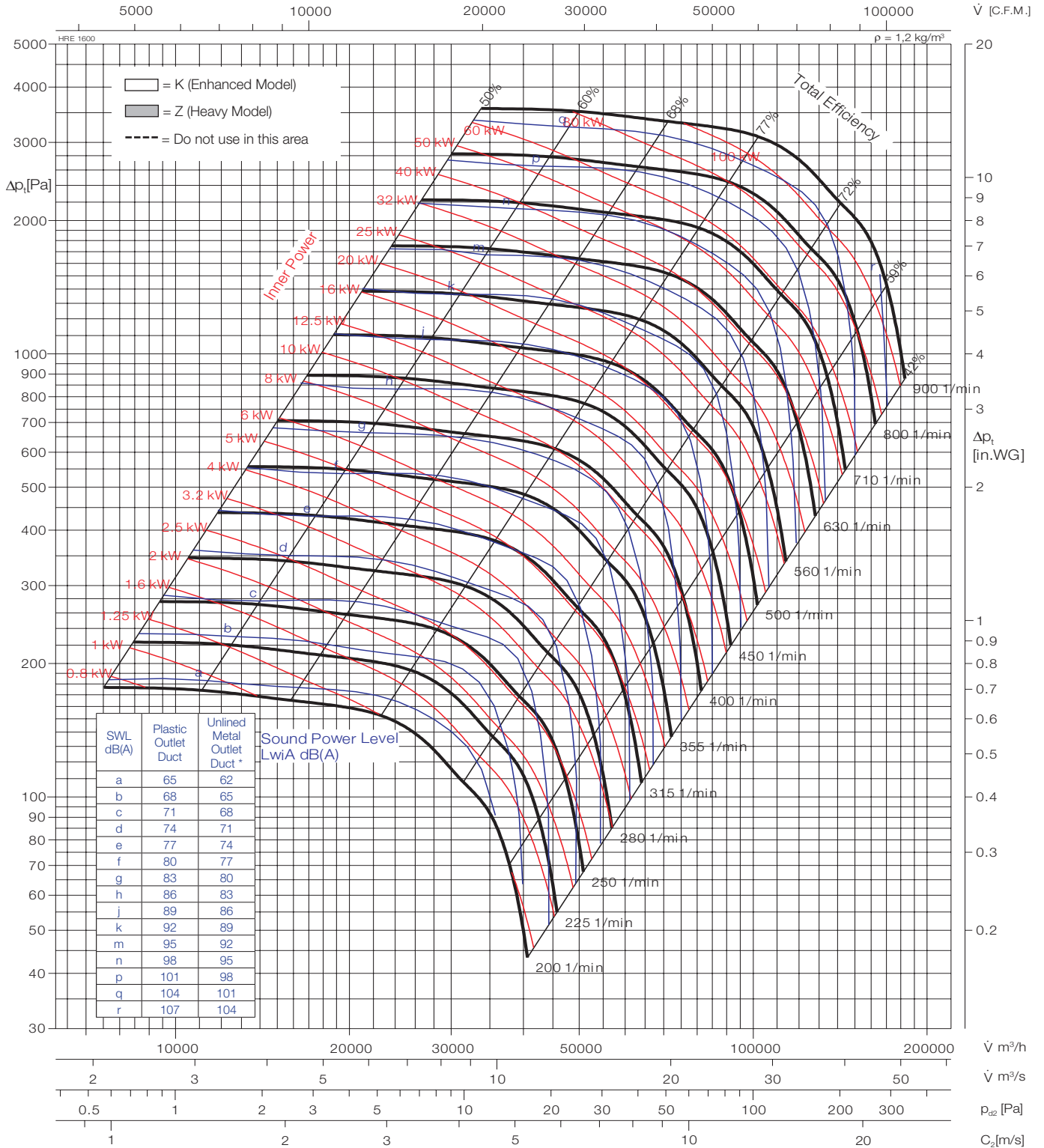

Typ	Art.Nr.	█ [kg]	Typ	Art.Nr.	█ [kg]
HRE 07 1600	-	1190			

Wheel diameter	D = 1605 mm
Number of blades	z = 16
Moment of inertia	J = 379,4 kgm ²
Wheel weight	G = 210 kg
Speed limit	n_{max} = 900 1/min

* Sound power level with unlined metal outlet duct were obtained from the test in the reverberant room. Data are not licensed by AMCA.



Performance Curve

HRE 1800



Fan test laboratory AMCA 210 Fig.12, 140000 CMH Test Chamber. Performance certified is for installation type B-Free inlet, Ducted outlet.

Power rating (kW) does not include transmission losses, Performance ratings do not include the effects of appurtenances (accessories). The A-weighted sound ratings shown have been calculated per AMCA International Standard 301. Values shown are for inlet LwiA sound power levels for installation Type B: free inlet, ducted outlet.

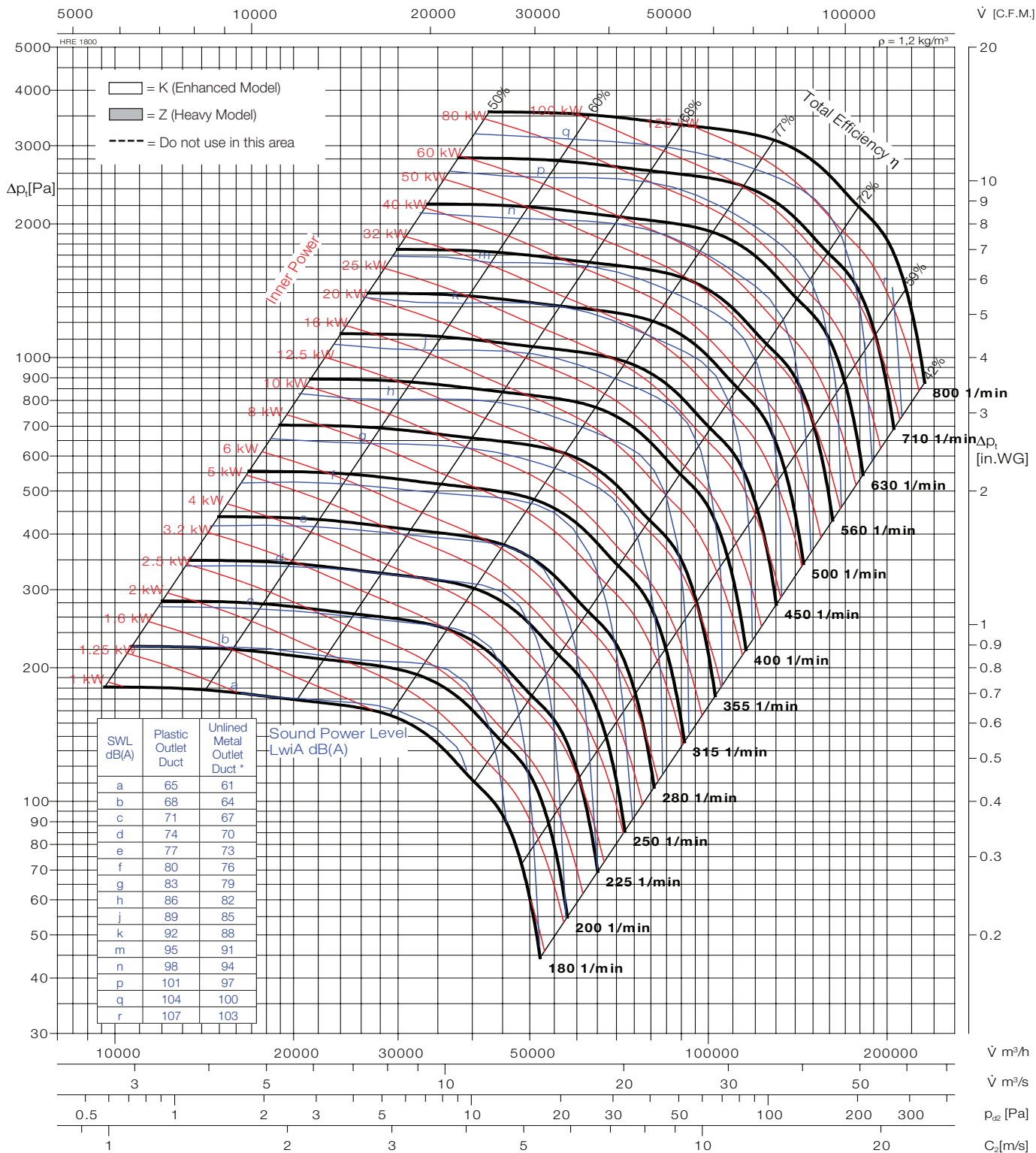

Typ	Art.Nr.	W [kg]
HRE 07 1800	-	3330

Typ	Art.Nr.	W [kg]

Wheel diameter	D = 1805 mm
Number of blades	z = 16
Moment of inertia	J = 604,9 kgm ²
Wheel weight	G = 266,0 kg
Speed limit	n_{max} = 800 1/min

* Sound power level with unlined metal outlet duct were obtained from the test in the reverberant room. Data are not licensed by AMCA.



Performance Curve

HRE 2000



Fan test laboratory AMCA 210 Fig.12, 140000 CMH Test Chamber. Performance certified is for installation type B-Free inlet, Ducted outlet.

Power rating (kW) does not include transmission losses, Performance ratings do not include the effects of apertures (accessories). The A-weighted sound ratings shown have been calculated per AMCA International Standard 301. Values shown are for inlet LwA sound power levels for installation Type B: free inlet, ducted outlet.

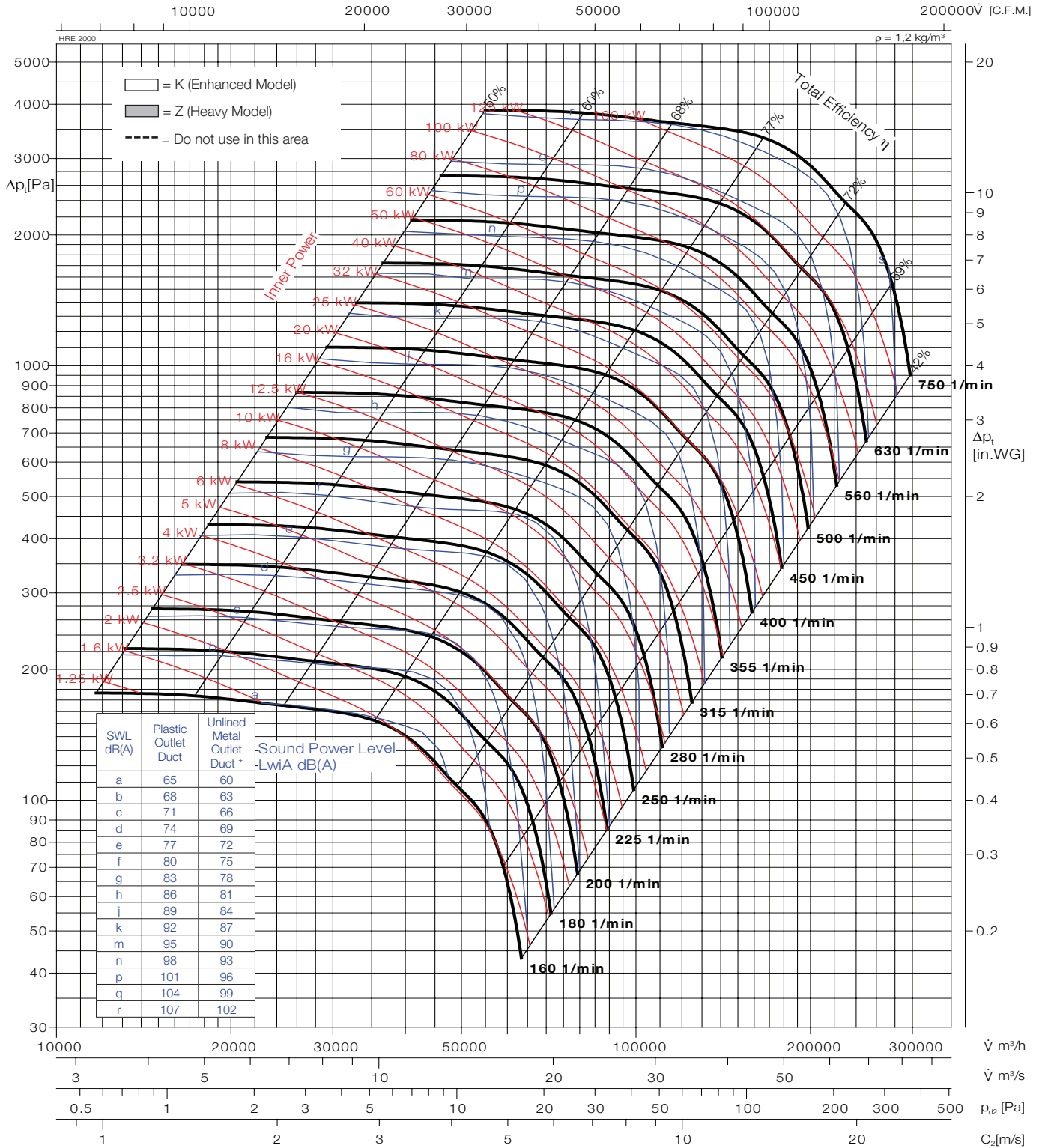

Typ	Art.Nr.	█ [kg]	Typ	Art.Nr.	█ [kg]
HRE 07 2000	-	3800			

Wheel diameter	D = 2005 mm
Number of blades	z = 16
Moment of inertia	J = 920,7 kgm ²
Wheel weight	G = 328,4 kg
Speed limit	n_{max} = 750 1/min

* Sound power level with unlined metal outlet duct were obtained from the test in the reverberant room. Data are not licensed by AMCA.



Fan Energy Index

Belt Driven, 50Hz



Introducing the Fan Energy Index

The FEI is a ratio of the actual fan efficiency to a baseline fan efficiency, both calculated at a given airflow and pressure point (FEI_s is calculated using a static pressure basis, FEI_t is calculated using a total pressure basis). Since these efficiencies are each calculated at the same airflow and pressure, FEI is also defined as the ratio of the baseline electrical power to the actual electrical power of a fan.

The FEI was designed to encourage responsible application of fans and drive significant and quantifiable energy savings through energy codes, utility rebate programs and federal regulations. This is accomplished by establishing the minimum fan efficiency or maximum fan electrical input power at design airflow and pressure. The FEI can be used by:

- Regulators to improve the efficiency of fan designs and limit market availability of less efficient fans
- Utilities to establish rebate programs to incentivize the efficient use of fans
- Code bodies to drive building owners and contractors to using more energy efficient fans for ventilation and process applications
- Purchasing agents to evaluate the fan selections and their suitability for specific applications

Selection Example

The **belt driven** centrifugal fan **HRE 560** with three-phase **50 Hz** motor power supply, by plotting the FEI curve as per the right graph, the FEI_t value will be 1.36 under the duty **7,000 CMH** airflow, **999 Pa total pressure** running at **1,400 rpm**.

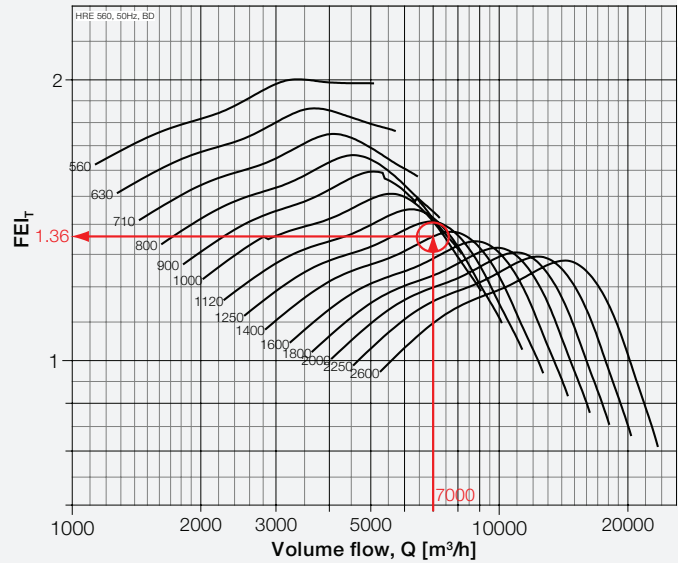

Belt Driven Models, Size from 315 to 2000, 50Hz

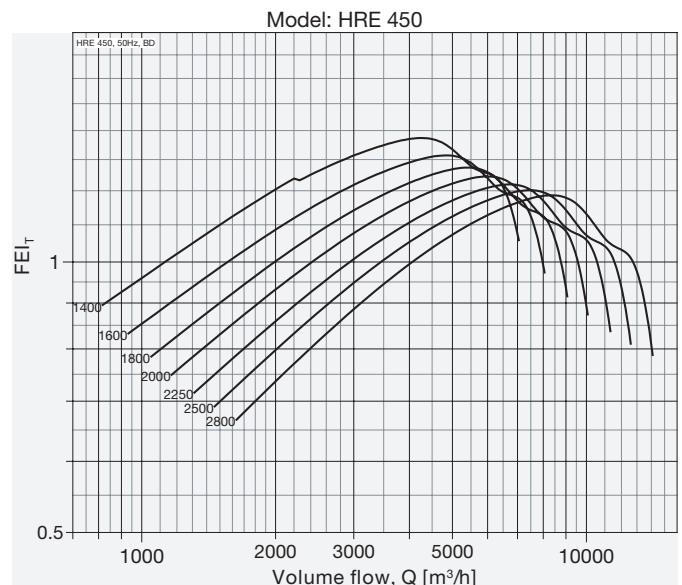
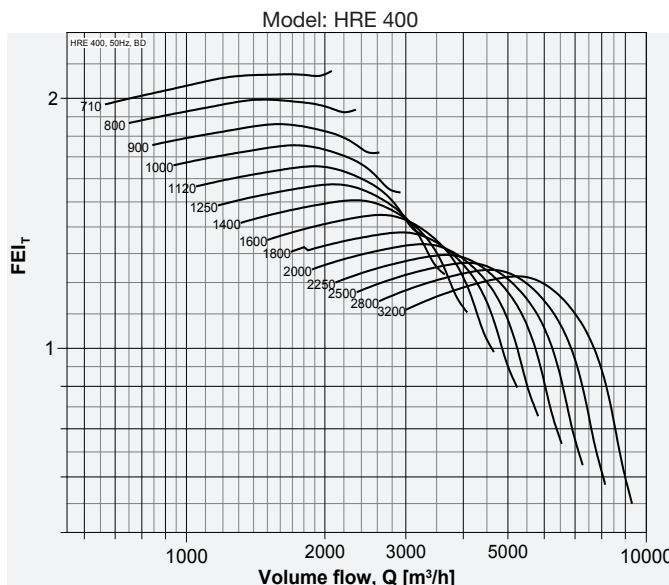
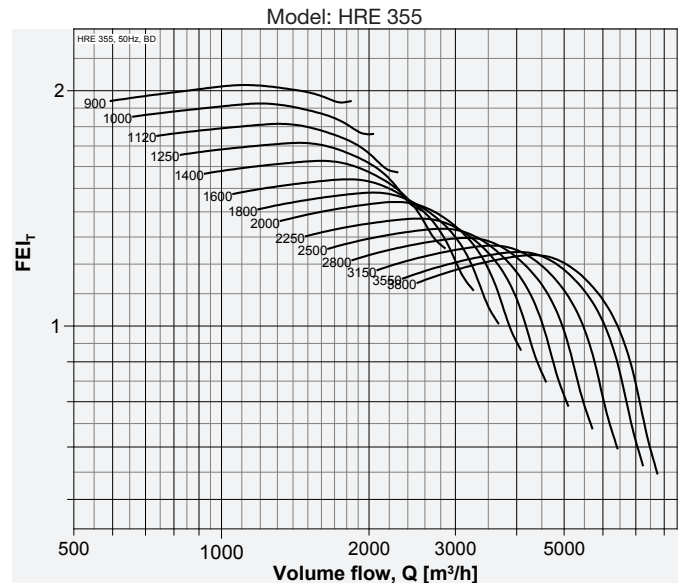
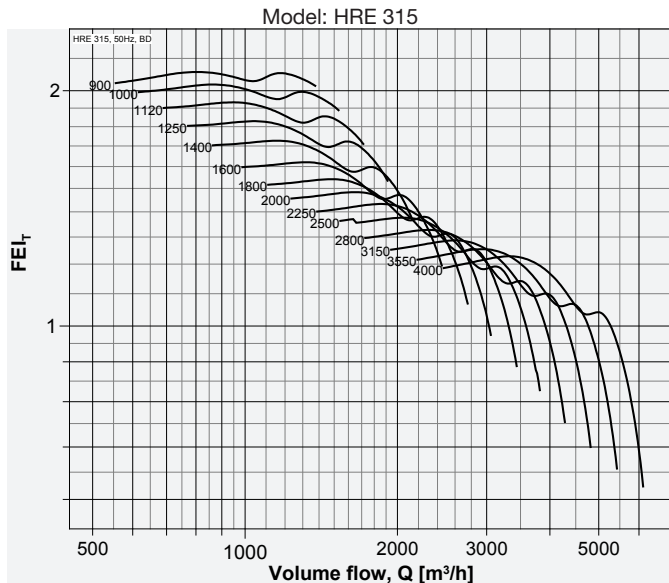

Performance certified is for installation type B - Free inlet, Ducted outlet. Power rating (kW) does not include transmission losses. Performance ratings do not include the effects of appurtenances (accessories-belt cover, pulley & belt). FEI_t values are calculated in accordance with ANSI/AMCA Standard 208 and are based on default motor efficiencies (Belt Driven type). FEI_t values for fans with specific motors will vary slightly from those shown. Fan speed shown in RPM.

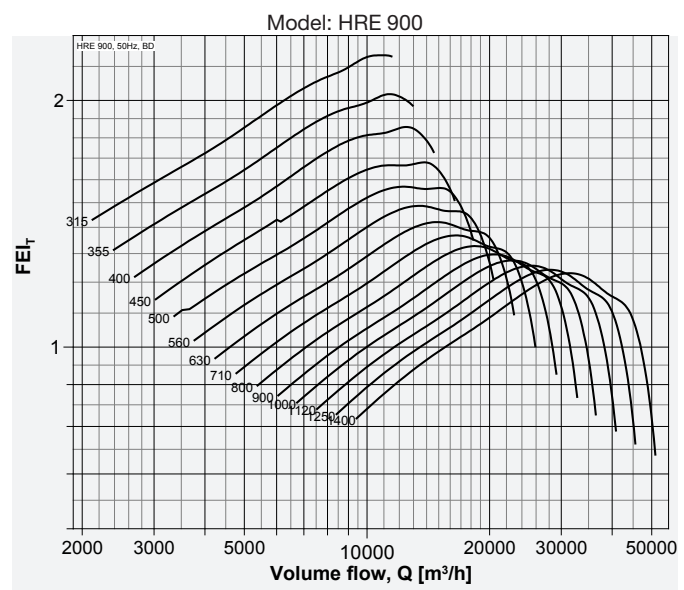
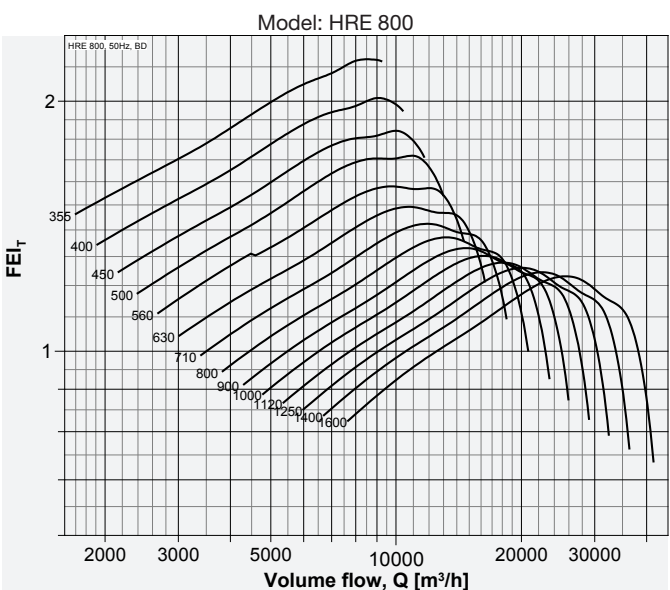
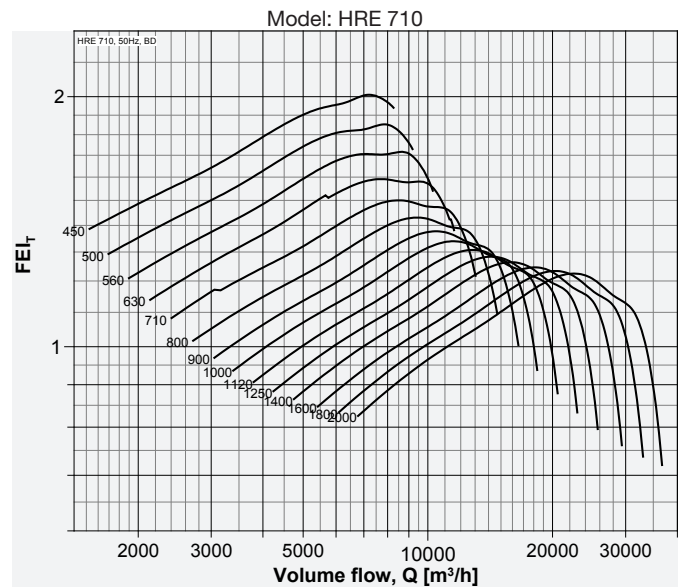
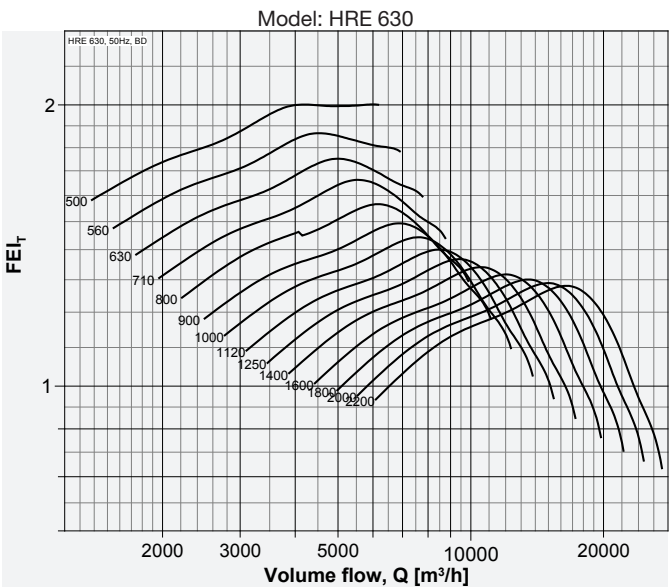
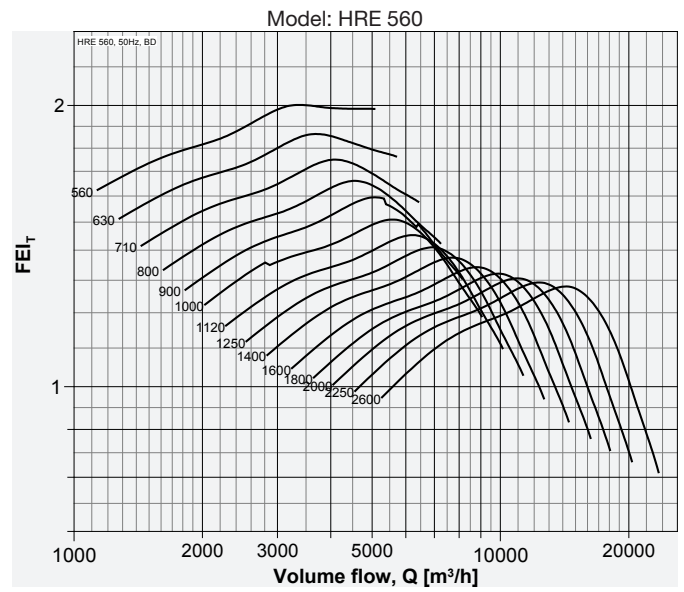
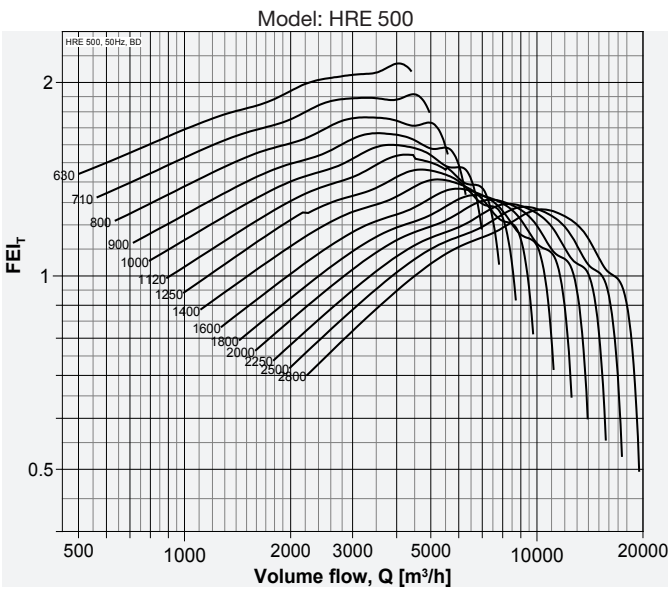

Performance certified is for installation type B - Free inlet, Ducted outlet. Power rating (kW) does not include transmission losses. Performance ratings do not include the effects of appurtenances (accessories-belt cover, pulley & belt). FEI_T values are calculated in accordance with ANSI/AMCA Standard 208 and are based on default motor efficiencies (Belt Driven type). FEI_T values for fans with specific motors will vary slightly from those shown. Fan speed shown in RPM.

Model: HRE 1000

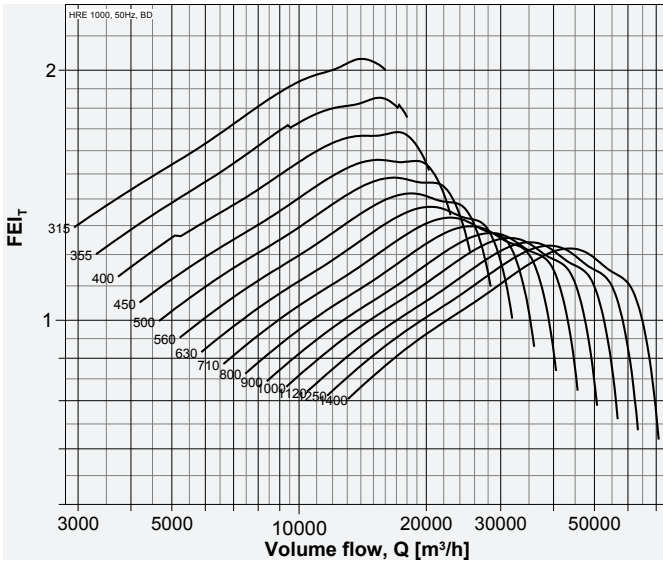

Model: HRE 1120

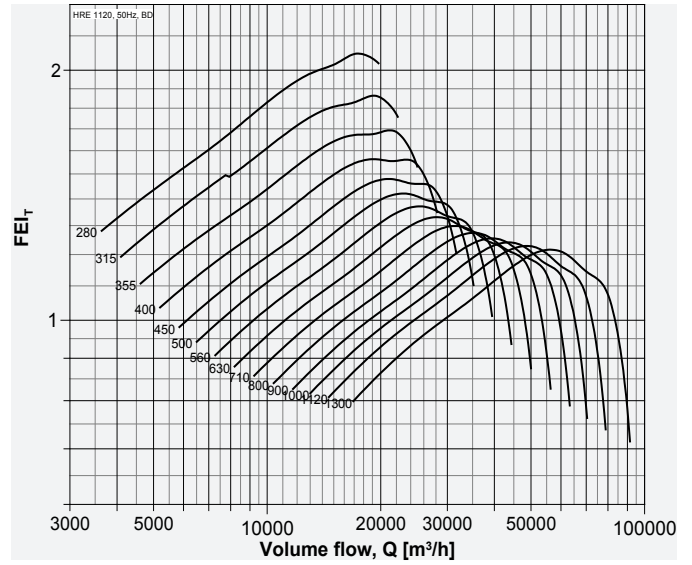

Model: HRE 1250

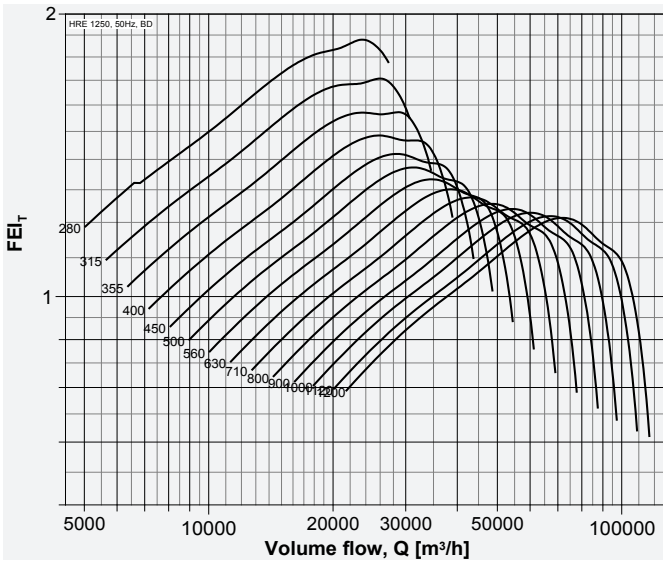

Model: HRE 1400

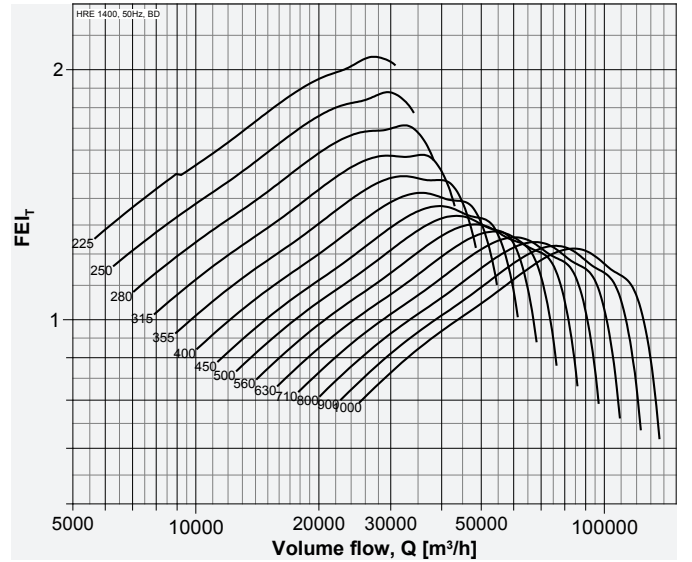

Model: HRE 1600

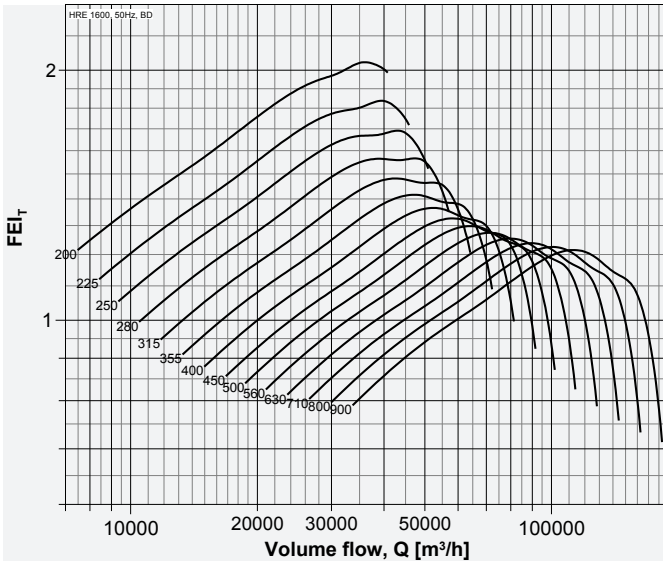

Model: HRE 1800

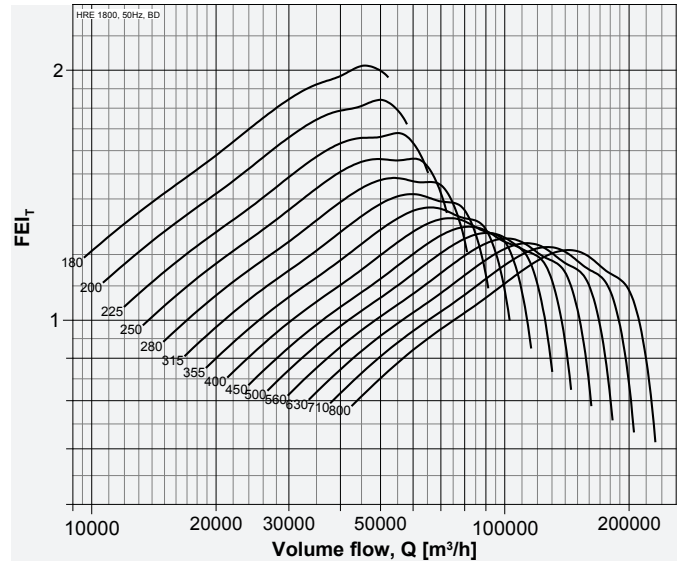

Performance certified is for installation type B - Free inlet, Ducted outlet. Power rating (kW) does not include transmission losses. Performance ratings do not include the effects of appurtenances (accessories-belt cover, pulley & belt). FEI_t values are calculated in accordance with ANSI/AMCA Standard 208 and are based on default motor efficiencies (Belt Driven type). FEI_t values for fans with specific motors will vary slightly from those shown. Fan speed shown in RPM.

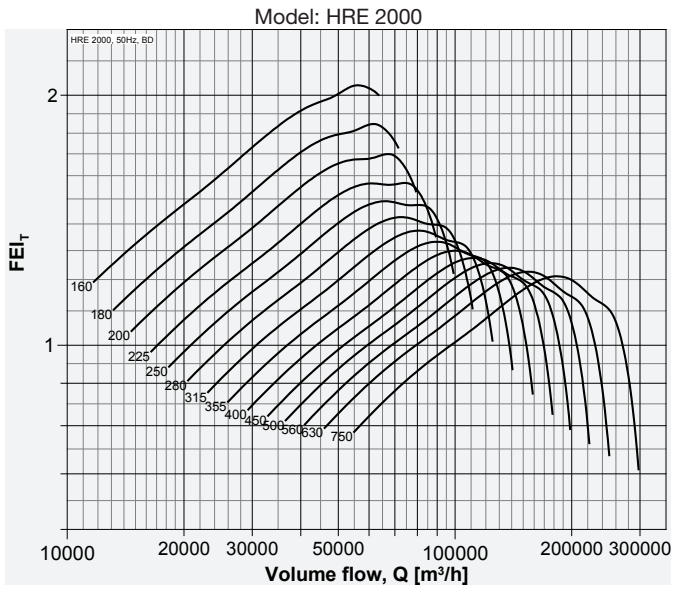

Performance certified is for installation type B - Free inlet, Ducted outlet. Power rating (kW) does not include transmission losses. Performance ratings do not include the effects of appurtenances (accessories-belt cover, pulley & belt). FEI_T values are calculated in accordance with ANSI/AMCA Standard 208 and are based on default motor efficiencies (Belt Driven type). FEI_T values for fans with specific motors will vary slightly from those shown. Fan speed shown in RPM.

Dimensions

HRE



HRE 05

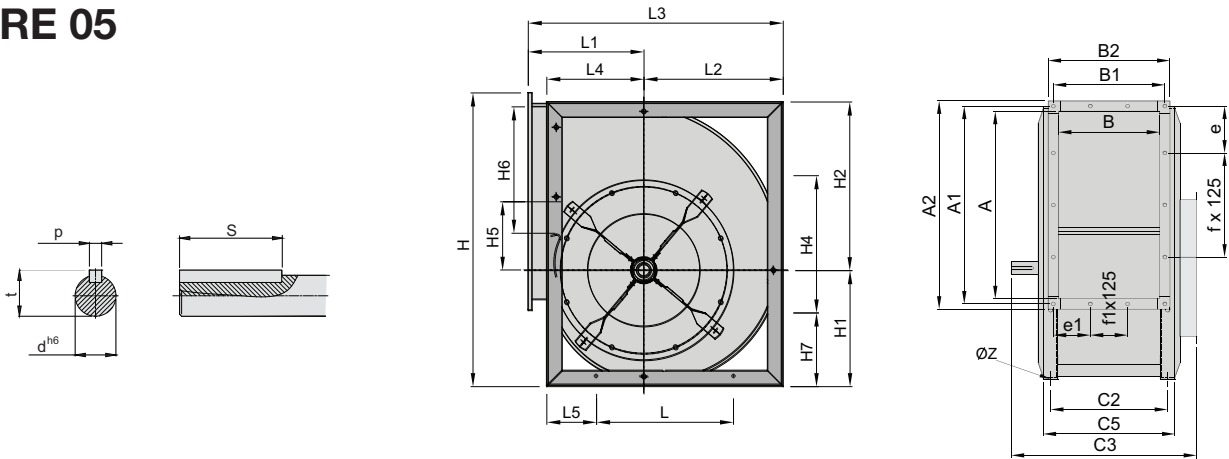

Model	A	A1	A2	A3	B	B1	B2	C	C1	C2	C3	C4	C5	C6	d	e	e1
size	[mm]	[mm]	[mm]	[mm]	[mm]	[mm]	[mm]	[mm]	[mm]	[mm]	[mm]	[mm]	[mm]	[mm]	[mm]	[mm]	[mm]
315	404	434	460	-	223	253	279	-	-	434	440	-	283	-	25	-	-
355	453	483	509	-	247	277	303	-	-	493	470	-	318	-	30	-	-
400	507	537	563	-	276	304	330	-	-	547	497	-	338	-	30	168.5	-
450	569	599	625	-	310	338	364	-	-	609	556	-	368	-	35	199.5	-
500	638	658	684	-	344	374	400	-	-	678	592	-	404	-	35	204	-
560	715	745	771	-	383	413	439	-	-	765	640	-	468	-	40	247.5	-
630	801	831	857	-	432	462	488	-	-	851	690	-	512	-	45	265.5	-

Model	F	fx125	f1x125	H	H1	H2	H3	H4	H5	H6	H7	L	L1	L2	L3	L4	L5	S	t	p	ØZ
size	[mm]	[mm]	[mm]	[mm]	[mm]	[mm]	[mm]	[mm]	[mm]	[mm]	[mm]	[mm]	[mm]	[mm]	[mm]	[mm]	[mm]	[mm]	[mm]	[mm]	[mm]
315	-	-	-	578	235	343	343	280	138	240	149	280	236	282	518	198	100	60	28	8	13
355	-	-	-	655	266	389	389	355	156	270	150	355	261	317	578	231	97	60	33	8	13
400	-	-	-	736	301	436	436	355	178	311	190	355	290	361	651	252	129	60	33	8	13
450	-	-	-	827	336	491	491	530	202	358	149	530	322	404	726	277	76	70	38	10	13
500	-	-	-	918	375	543	543	530	219	379	194	530	352	448	800	302	110	70	38	10	13
560	-	-	-	1030	420	610	610	530	245	424	250	530	390	503	893	342	158	70	43	12	13
630	-	-	-	1157	472	685	685	530	278	481	314	530	434	565	999	381	208	70	48	14	13

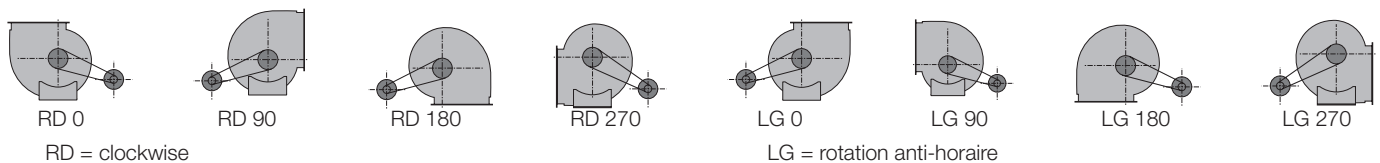

The direction of rotation is defined by vue on the side of drive.

We reserve the right to alter measurements without notice in case of technical improvements

Dimensions

HRE



HRE 315 - 1400 / 0°

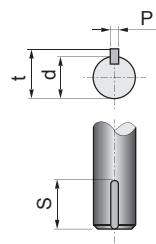
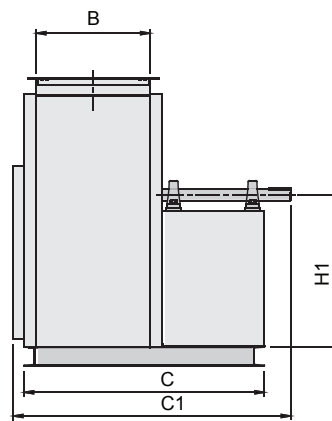
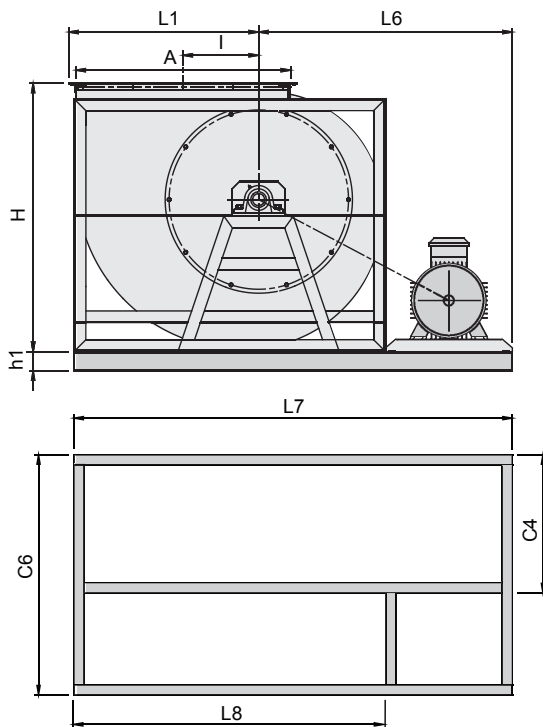

Basic frame and motor slide are included in the fan unit.

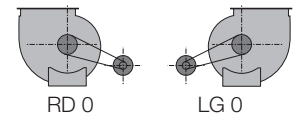

Model size	A [mm]	B [mm]	C [mm]	C1 [mm]	C4 [mm]	C6 [mm]	H [mm]	H1 [mm]	h1 [mm]	I [mm]	L1 [mm]	L6 [mm]	L7 [mm]	L8 [mm]	p [mm]	S [mm]	t [mm]	d [mm]
315	404	223	556	612	283	556	518	332	50	138	368	733	1073	578	8	40	28	25
355	453	247	627	697	327	627	578	367	50	157	411	767	1150	655	8	50	33	30
400	507	274	654	724	354	654	651	411	50	178	460	835	1266	736	8	50	33	30
450	569	308	728	816	388	728	726	454	50	202	514	871	1357	827	10	70	38	35
500	638	344	764	850	424	764	800	528	80	219	561	910	1448	918	10	70	38	35
560	715	383	855	945	483	855	893	583	80	246	631	1057	1660	1030	12	90	43	40
630	801	432	904	994	532	904	999	645	80	278	707	1109	1787	1157	12	90	43	40
710	898	478	1005	1115	578	1005	1121	716	80	316	793	1168	1933	1303	14	90	48,5	45
800	1007	533	1060	1170	633	1060	1250	795	80	359	890	1292	2154	1468	14	90	48,5	45
900	1130	595	1191	1313	715	1191	1408	904	100	406	999	1363	2334	1648	16	100	58,5	55
1000	1267	664	1259	1381	783	1259	1541	984	100	433	1094	1430	2496	1810	16	100	58,5	55
1120	1416	744	1399	1557	890	1399	1768	1117	120	507	1203	1518	2682	2052	18	120	69	65
1250	1578	825	1565	1740	968	1565	1950	1230	120	539	1345	1705	3038	2270	20	140	74,5	70
1400	1744	938	1751	1910	1053	1751	2160	1360	120	620	1502	1921	3433	2511	22	140	74,5	80

NB: Model 1600, 1800 and 2000, please contact Wolter for overall dimensions.

Dimensions

HRE



HRE 315-1400 / 90°

Basic frame and motor slide are included in the fan unit.

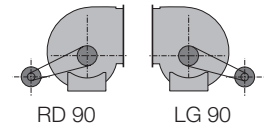
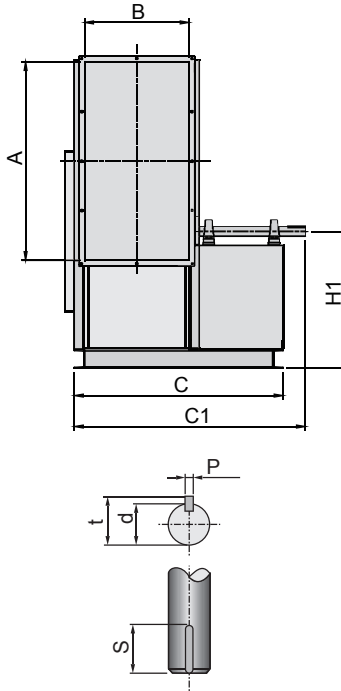
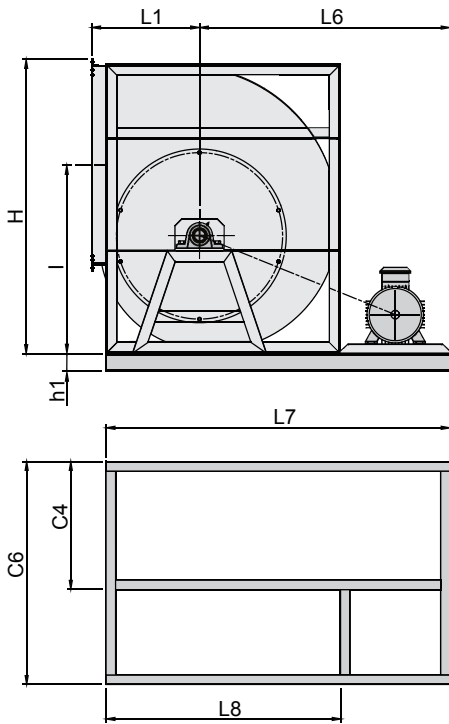

Model size	A [mm]	B [mm]	C [mm]	C1 [mm]	C4 [mm]	C6 [mm]	H [mm]	H1 [mm]	h1 [mm]	I [mm]	L1 [mm]	L6 [mm]	L7 [mm]	L8 [mm]	p [mm]	S [mm]	t [mm]	d [mm]
315	404	223	556	612	283	556	641	288	50	376	236	777	975	480	8	40	28	25
355	453	247	627	697	327	627	718	322	50	429	261	812	1043	548	8	50	33	30
400	507	274	654	724	354	654	799	355	50	483	290	891	1143	613	8	50	33	30
450	569	308	728	816	388	728	890	391	50	543	322	934	1211	681	10	70	38	35
500	638	344	764	850	424	764	1011	460	80	599	352	978	1280	750	10	70	38	35
560	715	383	855	945	483	855	1123	507	80	673	390	1133	1475	845	12	90	43	40
630	801	432	904	994	532	904	1250	559	80	757	434	1195	1576	946	12	90	43	40
710	898	478	1005	1115	578	1005	1396	618	80	854	485	1266	1688	1058	14	90	48,5	45
800	1007	533	1060	1170	633	1060	1561	686	80	965	535	1401	1867	1181	14	90	48,5	45
900	1130	595	1191	1313	715	1191	1761	777	100	1083	604	1490	2005	1319	16	100	58,5	55
1000	1267	664	1259	1381	783	1259	1923	844	100	1177	657	1570	2148	1462	16	100	58,5	55
1120	1416	744	1399	1557	890	1399	2153	961	120	1323	758	1627	2305	1675	18	120	69	65
1250	1578	825	1565	1740	968	1565	2390	1057	120	1476	840	1897	2612	1825	20	140	74,5	70
1400	1744	938	1751	1910	1053	1751	2642	1153	120	1563	920	2107	2917	1975	22	140	74,5	80

NB: Model 1600, 1800 and 2000, please contact Wolter for overall dimensions.

Dimensions

HRE



HRE 315-1400 / 270°

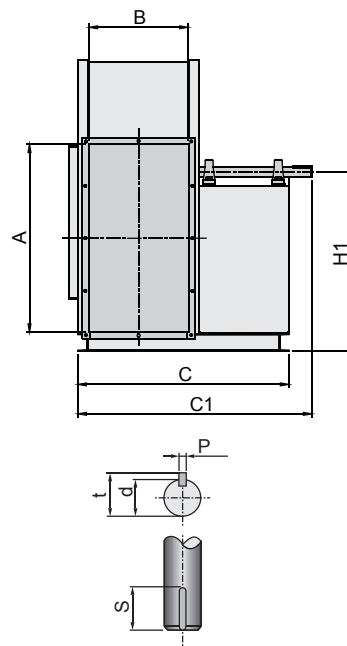
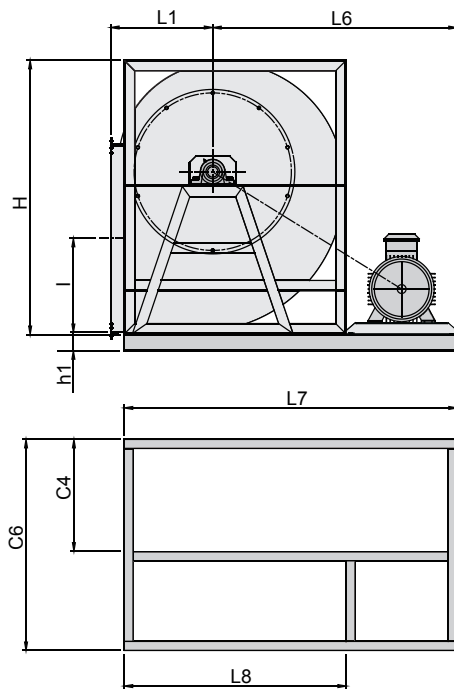

Basic frame and motor slide are included in the fan unit.

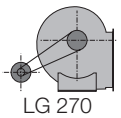
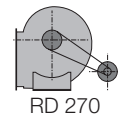
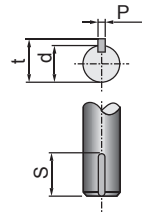

Model size	A [mm]	B [mm]	C [mm]	C1 [mm]	C4 [mm]	C6 [mm]	H [mm]	H1 [mm]	h1 [mm]	l [mm]	L1 [mm]	L6 [mm]	L7 [mm]	L8 [mm]	p [mm]	S [mm]	t [mm]	d [mm]
315	404	223	556	612	283	556	628	393	50	202	236	777	975	480	8	40	28	25
355	453	247	627	697	327	627	705	439	50	227	261	812	1043	548	8	50	33	30
400	507	274	654	724	354	654	786	486	50	254	290	891	1143	613	8	50	33	30
450	569	308	728	816	388	728	877	541	50	285	322	934	1211	681	10	70	38	35
500	638	344	764	850	424	764	998	623	80	319	352	978	1280	750	10	70	38	35
560	715	383	855	945	483	855	1110	691	80	358	390	1133	1475	845	12	90	43	40
630	801	432	904	994	532	904	1237	766	80	401	434	1195	1576	946	12	90	43	40
710	898	478	1005	1115	578	1005	1383	852	80	449	485	1266	1688	1058	14	90	48,5	45
800	1007	533	1060	1170	633	1060	1548	949	80	504	535	1401	1867	1181	14	90	48,5	45
900	1130	595	1191	1313	715	1191	1748	1078	100	565	604	1490	2005	1319	16	100	58,5	55
1000	1267	664	1259	1381	783	1259	1910	1142	100	634	657	1570	2148	1462	16	100	58,5	55
1120	1416	744	1399	1557	890	1399	2166	1312	120	722	758	1627	2305	1675	18	120	69	65
1250	1578	825	1565	1740	968	1565	2403	1453	120	806	840	1772	2612	1825	20	140	74,5	70
1400	1744	938	1751	1910	1053	1751	2655	1542	120	886	920	1887	2917	1975	22	140	74,5	80

NB: Model 1600, 1800 and 2000, please contact Wolter for overall dimensions.

We reserve the right to alter measurements without notice in case of technical improvements

Dimensions

HRE

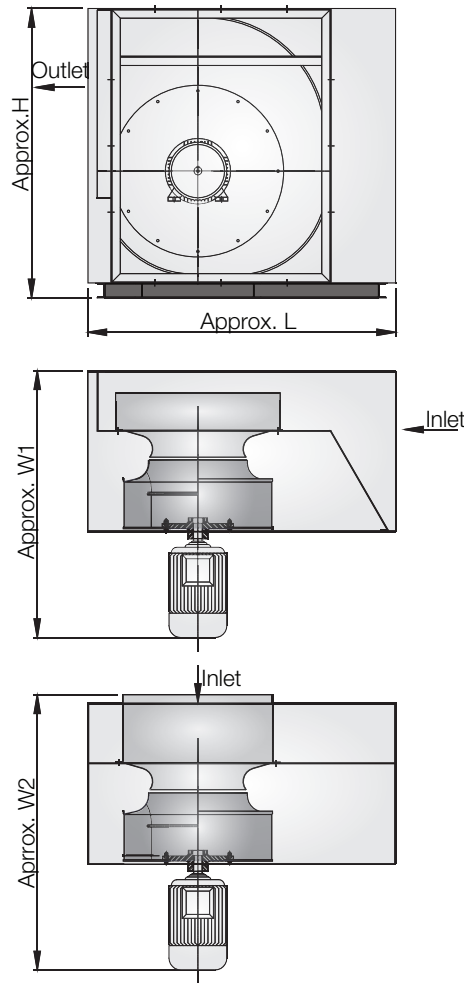

Fan with this configuration are not licensed to bear the AMCA Seal.

Model size	H [mm]	L [mm]	W1 [mm]	W2 [mm]	Motor size
315	691	753	688	733	90S
355	768	825	748	793	90L
400	849	919	796	841	90L
450	940	1018	882	927	100L
500	1091	1102	960	1005	112M
560	1203	1224	1112	1157	132S
630	1330	1356	1225	1270	132M
710	1476	1503	1294	1339	132M
800	1641	1672	1490	1535	160M
900	1861	1863	1639	1684	160L
1000	2023	2035	1751	1796	160L
1120	2273	2183	2016	2061	200L
1250	2510	2415	2152	2197	225S
1400	2762	2705	2413	2458	250M

NB: Dimension above for the fan with LG / RD 90 Deg and 270 Deg. Model 1600, 1800 and 2000, please contact Wolter for overall dimensions.

For smoke spill applications the model of fan used is type HRE (backward curve impeller). Impellers and inlet cones are manufactured from mild steel and suitably reinforced for high temperatures applications.

We reserve the right to alter measurements without notice in case of technical improvements.

Fan Laws - Proportional Laws

Here are some useful information and fan laws:

Speed change - constant size

- Volume flow \approx rotational speed

$$\frac{\dot{V}_2}{\dot{V}_1} = \frac{n_2}{n_1}$$

- Pressure (all) \approx (rotational speed)²

$$\frac{\Delta p_1}{\Delta p_2} = \left(\frac{n_1}{n_2}\right)^2 = \left(\frac{\dot{V}_1}{\dot{V}_2}\right)^2$$

- Power absorbed \approx (rotational speed)³

$$\frac{P_1}{P_2} = \left(\frac{n_1}{n_2}\right)^3 = \left(\frac{\dot{V}_1}{\dot{V}_2}\right)^3$$

Density change - constant speed - constant size

- Volume flow no change

$$\dot{V} = \text{constant}$$

- Pressure \approx Density

$$\frac{\Delta p_1}{\Delta p_2} = \frac{\rho_1}{\rho_2} = \frac{T_2}{T_1}$$

- Power absorbed \approx Density

$$\frac{P_1}{P_2} = \frac{\rho_1}{\rho_2} = \frac{T_2}{T_1}$$

Size change - constant speed (for geometrically similar fans only)

- Volume flow \approx (impeller Diameter)³

$$\frac{\dot{V}_2}{\dot{V}_1} = \left(\frac{D_2}{D_1}\right)^3$$

- Pressure \approx (impeller Diameter)²

$$\frac{\Delta p_1}{\Delta p_2} = \left(\frac{D_1}{D_2}\right)^2$$

- Power absorbed \approx (impeller Diameter)⁵

$$\frac{P_1}{P_2} = \left(\frac{D_1}{D_2}\right)^5$$

Pressure

- Dynamic Pressure [Pa]

$$p_d = \frac{\rho}{2} \cdot v^2$$

whereby:

ρ = air density in [kg/m³]

v = air velocity in [m/s]

- Total pressure

$$p_t = p_{st} + p_d$$

Absorbed power - calculation in duty point

$$P_L [\text{kW}] = \frac{\dot{V} [\text{m}^3/\text{s}] \cdot \Delta p_t [\text{Pa}]}{A_2 \cdot 1000}$$

1. Characteristic Fan Curve

This is the characteristic curve, which is determined on a test bed experimentally for every type of fan. This shows that the fan can in principle only operate on its characteristic curve, i.e. the operating point of a fan always lies on its characteristic curve.

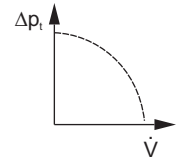

2. Characteristic Curve of the Plant

(Resistance Parabola)

Each plant has its own characteristic curve (resistance parabola), which by advance calculation can be determined more or less exact, so that the path of the characteristic curve can be drawn with sufficient accuracy.

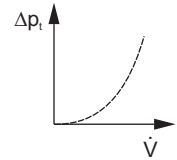

3. Coordination between Fan and Plant

The operating point of the fan always lies at the intersection of characteristic fan curve and characteristic plant curve (resistance parabola). From this results the actually moved volume flow, and the actual pressure difference to be overcome by the fan;

among others the characteristic fan curve V ($n = \text{const.}$) is given, also the characteristic plant curve 1, so that the operating point B_1 with \dot{V}_1 and p_{t1} results.

Figure a) shows the conditions for a centrifugal fan wheel with backward curved blading and figure b) the conditions for a centrifugal fan wheel with forward curved blading. If the volume flow is to be throttled by ΔV to \dot{V}_2 without reducing the fan Speed, it is generally customary to fit an additional resistance in form of a throttle valve, orifice or similar into the plant.

Figs. a) and b) show that a pressure loss of the size Δp_{st} must be fitted into the plant in order to reduce the volume flow to \dot{V}_2 . The resistance parabola 1 of the plant thus changes into 2 so that the operating point B_2 follows.

This shows that a fan with forward curved blading can be throttled more economically as one with backward curved blading.

A throttling of the fan speed is to prefer to any other method for sound reasons.

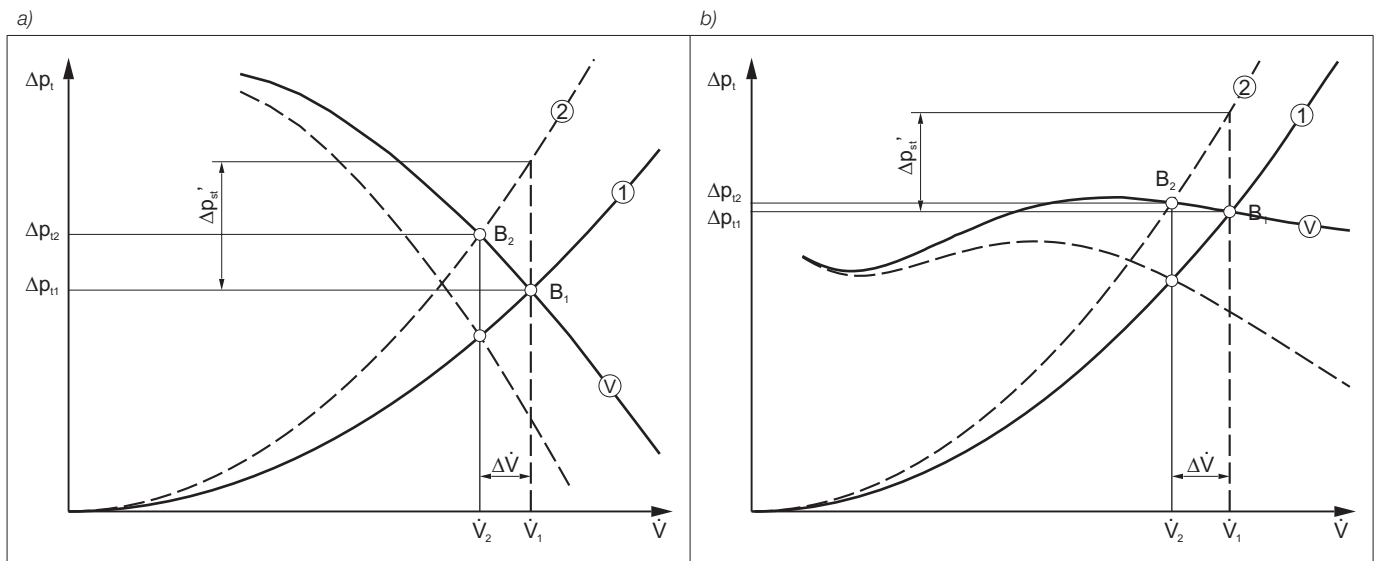

These fans are produced on modern machines and equipment. The rotors (impellers with shaft) are carefully balanced. Each fan is controlled and tested before it leaves the factory.

Before operating the fan, please check the following things

Check for transportation damages

Is the fan deformed? (Bulges, casing warped)

Does the impeller rotate without noise from the bearings, and without touching the inlet ring?

Check for foreign substances

Are there any foreign substances in the impeller or in the casing? If affirmative, it must be removed

Check for corrosion damages

The fans are supplied in very good galvanized finish. If stored for a longer period under humid and aggressive ambient conditions, zinc oxidizes. This has to be removed immediately (also inside the fan).

Assembly and mounting

The fan has to be mounted on the base or vibration dampers, with feet, square frame or base frame, in a way that it is not warped.

The shaft has to be horizontal.

Turn rotor (impeller with shaft) by hand. In case the impeller touches the inlet ring, loosen the inlet ring and refix it in a way that there is a uniform gap between inlet ring and impeller.

The fans are normally driven by a narrow belt drive. The instructions of the manufacturer of the belt drive have to be respected.

The bearings are temperature resistant from -30 degree C up to +85 degree C.

Depending on the location and way, how the fan is installed, different kinds of protection guards or devices could be necessary. DIN instructions or other instructions of local authorities or unions have to be respected.

The speed n_{max} indicated on the type plate may not be exceeded!

Operation

Switch on the fan for a short moment to check whether the direction of rotation is correct (See arrows at the fan casing).

If incorrect, change the direction of rotation by changing the wiring. (Respect the instructions of power supply companies).

Maintenance

The fans are maintenance free, only a control regarding contamination (fat, dust, etc.) has to be carried out.

The bearings are sealed for life with lithium base grease, suitable for approx. 20.000 operating hours. If the fan is operated more than 20.000 hours, or in case the bearings are damaged, they have to be exchanged (if bearings with rubber sealing, also this sealing has to be exchanged - a bearing chart is attached).

The bearings are equipped with a locking ring. To remove the bearing, this locking ring has to be loosened and the casing of the bearing has to be opened - then the bearing can be taken off from the cleaned and degreased shaft.

Important for a constantly good performance of the fan is a clean impeller.

Belt tension

Regular control of belt tension is very important. In any case, the belt tension has to be controlled after the first 100 operating hours, and then every 1000 operating hours or at least once a year. The belt tension is controlled by "pressing the belt with the fingers" (See drawing 1). A good tension is achieved by a total bending of approx. 2-3 cm. Used belts have to be replaced by belts of the same type. Control at the same time the fixation of the belt disc at the axis and the alignment of the belt. (See drawing 2)

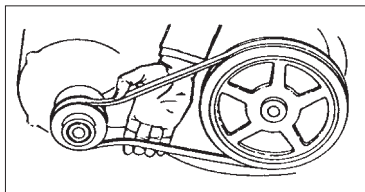

(Drawing 1) Belt tension bending of approx. 2-3 cm.

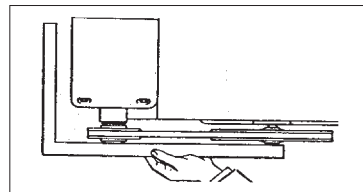

(Drawing 2) alignment of the belt disc.

Sales Network

Deutschland

Wolter GmbH.
Maschinen-und Apparatebau KG.
DE-76316 Malsch
T +49 (0) 72 04 / 92 01 0
F +49 (0) 72 04 / 92 01 11
info@wolter.eu

Europe

Denmark:

L.ØLAND VENTILATION A/S
DK-2605 Brøndby
T +45 (0) 70 / 20 19 11
salg@airforce.dk

Netherlands:

DE WIT Ventilatoren BV
NL-3821 CG Amersfoort
T +31 (0) 33 / 76 00 240
info@dewitventilatoren.nl

Sweden:

Nordisk Ventilator AB
SE-142 50 Skogås
T +46 (0) 8 / 72 70 250
se@nordiskventilator.se

Switzerland:

Anson AG Zürich
CH-8055 Zürich
T +41 (0) 44 / 46 11 111
F +41 (0) 44 / 46 13 111
info@anson.ch

OZ Tech SA
CH-1122 Romanel-sur-Morges
T +41 (0) 76 / 41 11 572
info@oztech.ch

United Kingdom:

Wolter (UK) Ltd.
GB-Leicestershire LE65 1AL
T +44 (0) 15 30 / 41 24 73
info@wolteruk.com

Middle East

UAE, Saudi Arabia, Qatar, Lebanon:

Please contact Wolter head office

Wolter GmbH.
Maschinen-und Apparatebau KG.
DE-76316 Malsch
T +49 (0) 72 04 / 92 01 0
F +49 (0) 72 04 / 92 01 11
info@wolter.eu

Asia

China:

Guangdong Wolter Chemco Ventilation Ltd.
Boluo, Huizhou, Guangdong

Dongguan Wolter Chemco Ventilation Ltd.
Shipai, Dongguan, Guangdong
T +86 (0) 769 / 8655 7298
F +86 (0) 769 / 8655 7278
info@wolter.com.hk

Taizhou Wolter Ventilation Co. Ltd.
Hengjie, Luqiao District,
Taizhou, Zhejiang
T +86 (0) 576 / 26 22 666 (26 52 888)
F +86 (0) 576 / 26 56 830

China - Hong Kong, Macau:

Wolter Asia Ltd
Kowloon, Hong Kong
T +852 (0) 2456 0198
F +852 (0) 2456 0290
info@wolter.com.hk

China - Taiwan:

Waxlink International Co., Ltd.
8F-2 No.218 Roosevelt Rd.,
Sec.6, Taipei, Taiwan
T +886 (0) 2 / 8932 1196
F +886 (0) 2 / 8932 1197
waxlink@mail.waxlinktw.com

India:

Wolter Ventilators India Pvt. Ltd.
867 D, Block-A, Sushant Lok, Phase-I,
Gurgaon - 122009 (Haryana)
T +91 (0) 124 2577797, 4261001-3
sales@wolterindia.in

Korea:

Kaceco-Wolter
14-1, Dang-dong, Gunpo-shi,
Gyeonggi-do
T +(82) 0 31 / 4773 104
F +(82) 0 31 / 4773 132
wolter@kaceco.com
info@kaceco.com

Malaysia:

Vibrantech (M) Sdn Bhd.
47200 Petaling Jaya Selangor
T +603 (0) 7847 3500
F +603 (0) 7847 3380
sales@vibrantech-sb.com

Singapore:

Wolter Pte. Ltd.
SG-569738 Singapore
T +65 (0) 63 / 52 95 48
F +65 (0) 63 / 52 95 47
info@wolterfans.com.sg

Thailand:

Wolter Ventilation Co., Ltd.
Thamai Kratumban Samutsakorn
741 10 Thailand
T +66 (0) 84 555 2936
kongsakol@wolterfan.com

Australia

The Sydney Fan Company.
NSW 2147, Sydney, Australia
T +61 (0) 2 / 9624 4000
F +61 (0) 2 / 9624 4100
sales@thesydneyfancompany.com

Wolter GmbH Maschinen-und Apparatebau KG

Am Wasen 11
DE-76316 Malsch / Germany
T +49 (0) 72 04 / 92 01 0
F +49 (0) 72 04 / 92 01 11
www.wolter.eu
info@wolter.eu



Air in Motion

Reference: **M08.HRE**, March 2025, Printed in March, 2025

Dongguan Wolter Chemco Ventilation Ltd. (Wolter Asia)

Shipai, Dongguan City, Guangdong Province, P.R.China

Tel. (+86)769 8655 7298, Fax (+86)769 8655 7278

www.wolterfans.com

info@wolterfans.com

