

Induced Flow Fans

- CHEM HS Series
- CHEM HE Series
- CHEM HDE Series



R10.5

wolter 

Table of Content

Content.....	1
Technical Description.....	2~9
Role.....	3
Products and Performance.....	3
Fume Jet Nozzles.....	3
Dispersion Height.....	3
Casing.....	3
Impellers.....	4
Fan Base and Support.....	4
Drive shaft and bearing.....	4
Drive.....	4
Motor.....	4
Standard Colours.....	4
Ancillary Equipment.....	4
Service.....	4
Fan Type Code.....	5
AMCA Induced Flow Licensed.....	5
Quality, Testing and Certification.....	5
AMCA 260 Air Test Procedure.....	6
Performance Curves.....	6
Sound Levels.....	7
Laboratory Exhaust System.....	8
Effective Plume Height Calculation.....	9
Pressure Loss and Effective Plume Height Selection.....	9
Performance Curve.....	10~36
FEI Curve.....	37~46
Pressure Loss.....	47~49
Plume Rise.....	50~53
Plenum Layout System.....	54~55
Nozzle Dimension.....	56~59

Subject to change without prior notice.

Conventional Stack



In contrast, traditional stack flues are exceptionally tall, incur substantial construction and maintenance costs, and can lead to local pollution build-up, thereby posing health risks to nearby communities.



Wolter Fume Jet System

- › High Plume / Induced Flow Fan ensures high efficiency and reliability in dispersion of fumes.
- › To prevent the plume down wash and limit exposure level that may be detrimental to the health.
- › Designers and engineers to specify the required dispersion height.
- › Suitable for use in hospitals, schools, waste treatment plants, restaurants, test and research laboratories etc.

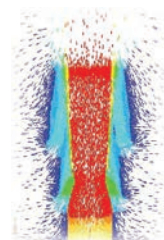

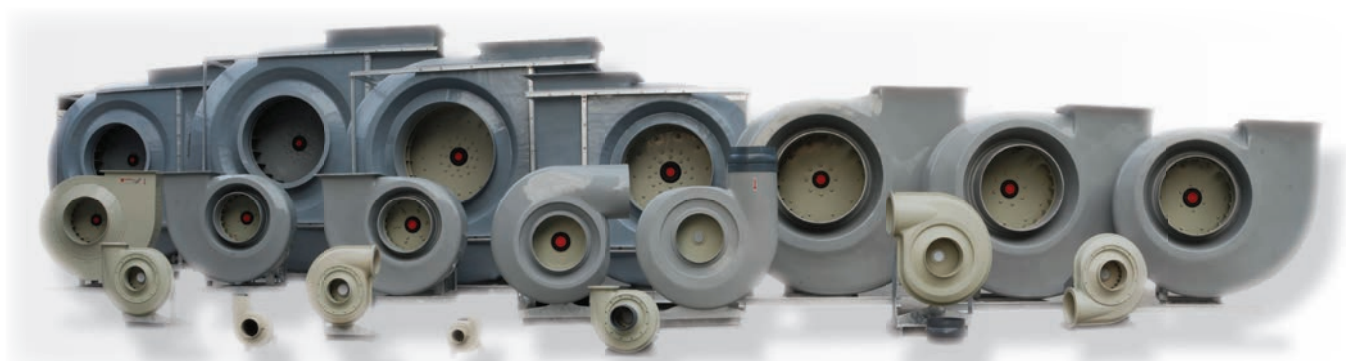

Role

Wolter's CHEMCO with over 30 years of manufacturing experience has become one of the world's leading Chemical Resistant Plastic Fan and Ventilator manufacturers.

The years of experience and know-how in the areas of fan engineering and its designing capabilities enable Wolter's CHEMCO to develop a complete range of both steel and plastic induced flow fan with axial, centrifugal or mixed flow impellers with high efficient fume jet dispersion stack.

Products and Performance

Wolter offers a complete range of high-quality induced flow fan with either centrifugal impellers for superior performance. Wolter's CHEMCO Fume Jet mounted on fan, with casing build to a true volute form, is tested in accordance to AMCA 210, AMCA 260 and AMCA 300 to give exact amount of air and velocity.

The Fume Jet comes with 2 types. HS type of single windband with low pressure losses. The HE type of single and double windband with higher plume and entrainment capability. Each type comes in 15 difference sizes. Capacity up to 96,000 cmh, static pressure up to 4,000 Pa and dispersion height close to 35 meter at 16Km/hr wind speed. The cone is designed to increase induce draft by up to 3 times the exhaust flow volume. Wolter's CHEMCO Chemical resistant plastic fans can be mounted with Fume Jet.

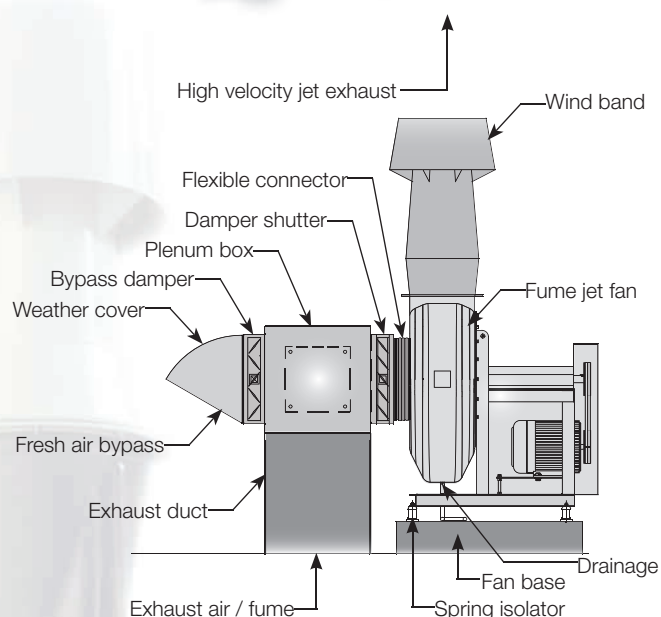

Fume Jet Nozzles

The Fume Jet nozzles are characterized by a vertical taper nozzle mounted which is mounted on the fan housing outlet for dispersion of fumes to the atmosphere to prevent the contamination from settling and plugging.

The Fume Jet nozzle is extremely rigid to ensure that it is free of vibration or drumming during operation. It is developed to give low noise level and trouble-free service.

Material of PP, PE, PVC, PVDF, GRP, epoxy coated steel or stainless steels offers superior corrosion resistance quality.

The Fume Jet nozzle is also designed to provide adequate exit velocities that will help prevent plume downwash. Usually it is 1.5 times the maximum expected wind speed at the nozzle exit (U.S. EPA, 1985).

Dispersion Height

The flow rate, the minimum nozzle velocity and the wind speed determine the dispersion height. The wind dictates the speed and direction in which the bulk of the plume moves, and wind also affects the amount of dispersion that takes place. The height to ensure that emissions do not result in excessive concentrations of the pollutant can be referred to (GEP) in 40 CFR 51 Section.

Plenum Box

The fan-inlet mixing plenum box is a critical component attached to the fan by chemical resistance flexible PVC connection. The plenum box facilitates the mixing of fresh ambient air with the laboratory exhaust polluted air. It is designed to ensure proper mixing of the two air streams, improving pollutant dilution and ventilation efficiency. Inside the mixing plenum box, the stainless steel isolation damper installed helps control the intake or recirculated air and the stainless steel bypass damper is integrated to introduce fresh ambient air into the system.

Casing

The fan casing is either made of PP, PE, PVC, PVDF, GRP, epoxy coated galvanized steel or stainless steels and offers

superior corrosion & UV resistance quality.

The casing is extremely rigid with adequate thickness, properly stiffened to ensure it is free of vibration or drumming during operation. The casing is also constructed in a way that no metal parts are situated in the airflow to eliminate the risk of corrosion. Casing can be of GRP or any thermoplastic material blended with composites to overcoming high temperature, flame retardant resistant, ultraviolet or Electrostatic Discharge protection to suit customer's requirements. The inlet and outlet are of standard diameter sizes, which can be easily connected together with flexible connector during installation. All casings can be fitted with drain outlets at the lowest point of the scrolls. This is to facilitate the drainage of condensation build-up or rainwater when installed in the open.

Impellers

Depending on the type of application, these impellers can be constructed of stainless steel, high-grade steel with epoxy coated for high temperature and anti corrosive resistance.

For adverse chemical resistance application, materials such as PA, PC, PVC, PVDF or GRP are used.

For flame-retardant properties, special reinforced compound materials with UV durability or protection against electrostatic discharge are used as well.

Each impeller is statically and dynamically balanced in two planes in accordance with Q2.5 of VDI 2060. All impellers are balanced to ANSI/AMCA Standard 204 BV level 4 standard, ISO 1940 & ISO 14694 international standards.

The impellers are designed for use with taper-bushes and are made of high-grade cast aluminum disks capable of running at high peripheral speeds.

Fan Base and Support

The supporting steel stands and fan bases are manufactured from heavy gauge mild steel and are hot-dip galvanised or epoxy powder coated to provide protection even in the most adverse conditions. Special surface treatments can be applied on request.

Drive shaft and bearing

All precision solid shafts complying to EN 10084 are trued and have a smooth finish. Both shaft ends have as standard feature diameters complying with ISO/R 775, Sheet 1 and grooved to ISO/R 773. The shafts are chemical resistant coated with protective cover to prevent corrosion. Upon requested, stainless steel shaft can also be provided.

CHEM 200 - 280 belt driven fans come with flange mounted aluminium cast bearing housings type. The drive shaft is fitted with two standards anti-friction grooved balls bearing unit with acid proof seal. This design ensures trouble-free service, silent operation and minimum vibration. For CHEM 315 and above, the drive shafts are mounted on fan pedestal with cast iron housing of plummer block units. These bearings are of self-aligning heavy-duty ball or spherical roller type.

Drive

For Belt driven applications, precisely balanced pulleys with tension sleeve are used. All belts comply with ISO 1081:2013. The belt-drive and all other rotating parts are fitted with a protection guard.

Motor

If the application requires, motors of different protection classes can be supplied. On direct-driven fans, B5 flange-type motors are mounted. All motors are totally enclosed and air-cooled. Single-phase motors or motors with non-standard voltages can be supplied upon request.

Standard Colours

- › All PP fans - PANTONE Warm Grey 1C
- › All GRP fans - PANTONE 430

If required, other colors can be supplied.

Ancillary Equipment

- › Spring anti-vibration mounts
- › Condensate drain plug
- › Fan and motor support base frame
- › Shaft and bearing cover
- › Inlet flanges, flexible connections with clamps
- › Splinter shield

Service

Wolter's CHEMCO always strive to offer the best "value for money" and to maintain its primary objective of ensuring that all our products are safe, easy to use, whilst offering reliable quality with the latest in design technology, incorporating all useful and practical features, leaving the customers with superior products and service.





Fan Type Code

CHEM	HS30	400	
			Fan Size 200 ... 1000
			Nozzle Type HS30, HE30, HE50, HDE90
			Fan Type

Dongguan Wolter Chemco Ventilation Ltd. certifies that the Series CHEM HS30 and CHEM HE30 shown herein are licensed to bear the AMCA Seal. The ratings shown are based on tests and procedures performed in accordance with AMCA Publication 211 and AMCA Publication 311 and comply with the requirements of the AMCA Certified Ratings Program.

AMCA Induced Flow Licensed

The Air Movement and Control Association (AMCA) International, Inc. has introduced AMCA Standard 260, "Laboratory Methods of Testing Induced Flow Fans for Rating." Induced flow fans, also known as high plume dilution blowers, are used to dilute hazardous laboratory exhaust and disperse the exhaust high into the atmosphere, away from possible re-entrainment zones. AMCA Standard 260 can provide consulting and facility engineers independent performance verification for critical laboratory exhaust applications that they insist on for other fans and blowers used in general HVAC applications.

The AMCA Induced Flow Fan seal encompasses the following AMCA test standards:

- › ANSI/AMCA Standard 210, "Laboratory Methods of Testing Fans for Certified Aerodynamic Performance Rating"
- › AMCA Standard 260, "Laboratory Methods of Testing Induced Flow Fans for Rating"
- › AMCA Standard 300, "Reverberant Room Method for Sound Testing of Fans"

Quality, Testing and Certification

The Fume Jets are produced to strict quality standards. Only the best quality materials are used.

Our assembly, logistic and R&D centre has been certified in accordance to ISO 9001-2015 ensuring that all our products meet the highest standards of quality and each item is carefully inspected before shipment to ensure customer satisfaction.

Our testing facilities include the latest state of-the-art equipments. Fans mounted with Fume Jet are rated and tested in accordance to ISO 5801 and AMCA 210, 260 and 300 standards. In many cases, factory acceptance tests (FAT) are arranged prior to delivery to ensure that all specifications and standards are met.

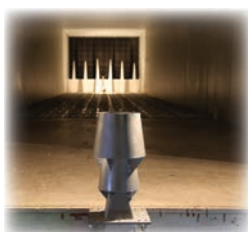

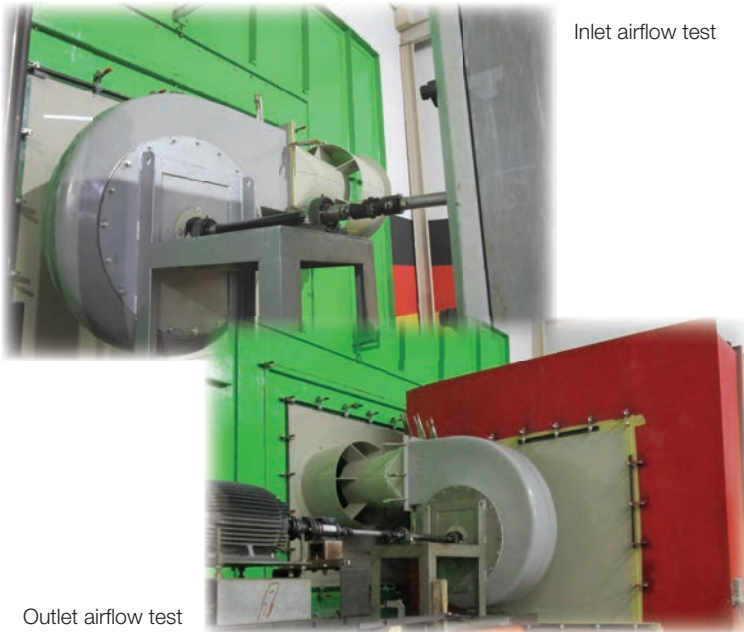

AMCA 260 Air Test Procedure

The following illustrations describe the procedure for determining the total laboratory exhaust fan discharge flow. The total discharge flow is the sum of inlet airflow and entrained airflow. The inlet air flow is determined first by using AMCA 210 Figure 15. Next, the key requirement to AMCA 260 is the variable resistance box. This box allows the measurement of total discharge flow ($P_s = 0$ Pa) to simulate discharging the fan to atmosphere) at all points along its fan curve. Without the variable resistance box, the entrained airflow can only be measured at the free air point of its fan curve. The entrained airflow obtained can be used to calculate an effective plume height. Therefore, AMCA 260 certification is necessary to ensure the laboratory exhaust fan specified is providing the plume rise and entrainment submitted.

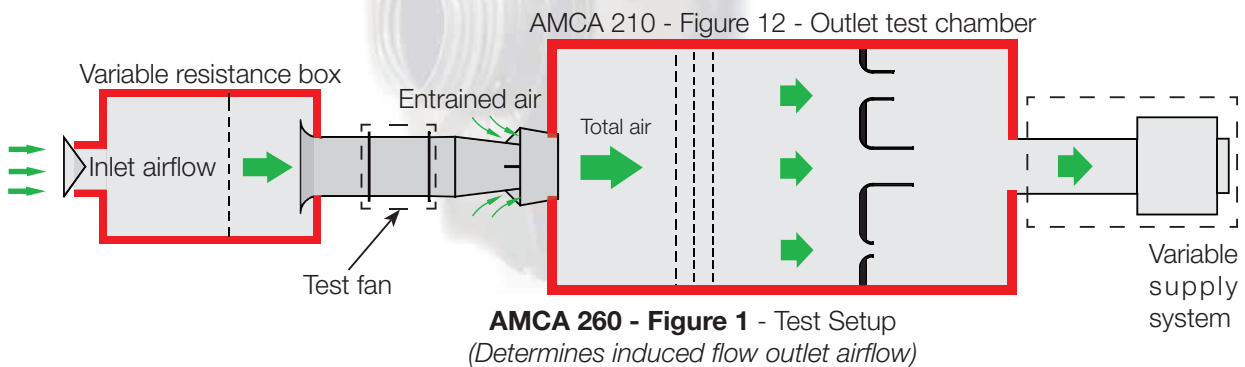
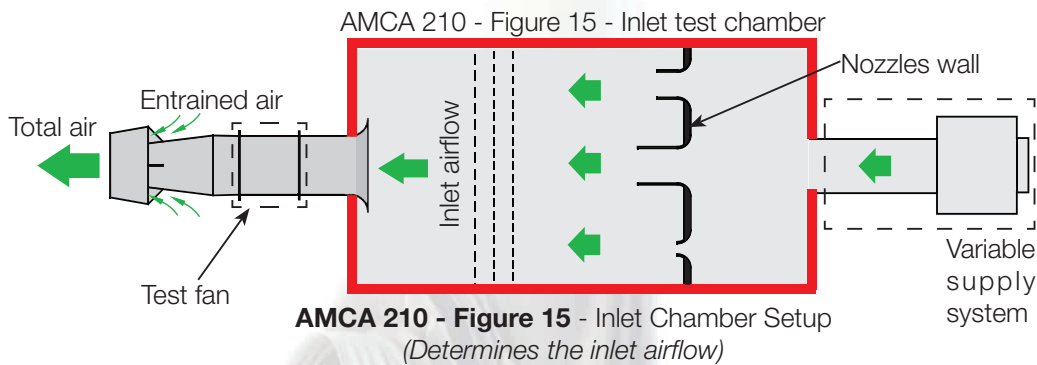

Performance Curves

The performance curves have been established using the inlet test method in the test chamber according to AMCA 210 installation type C (duct inlet, free outlet).

The curves indicate as a function of the volume flow:

- ▶ fan inlet airflow: the static pressure increase p_s for constant speed (heave black lines)
- ▶ windband outlet airflow: the static pressure increase p_s for constant speed (heave green lines)
- ▶ constant lines of shaft power P_w (red Lines)

All values relate to an air density: $\rho = 1.2 \text{ kg/m}^3$ at 20°C

The nozzle outlet velocity c_1 stated in the diagrams refer to the airflow of fan inlet and the outlet diameter of nozzle;

The windband outlet velocity c_2 stated in the diagrams refer to the airflow of windband outlet and the outlet diameter of windband;

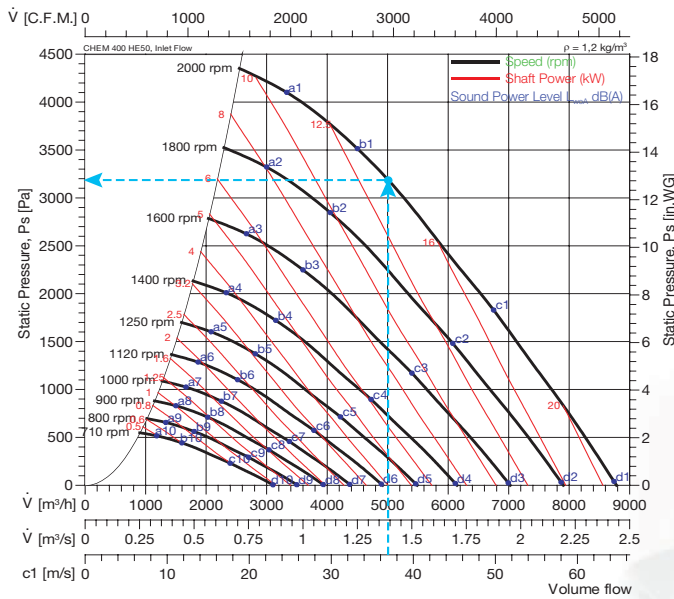

Figure 4, CHEM HE50 400 Inlet airflow curve

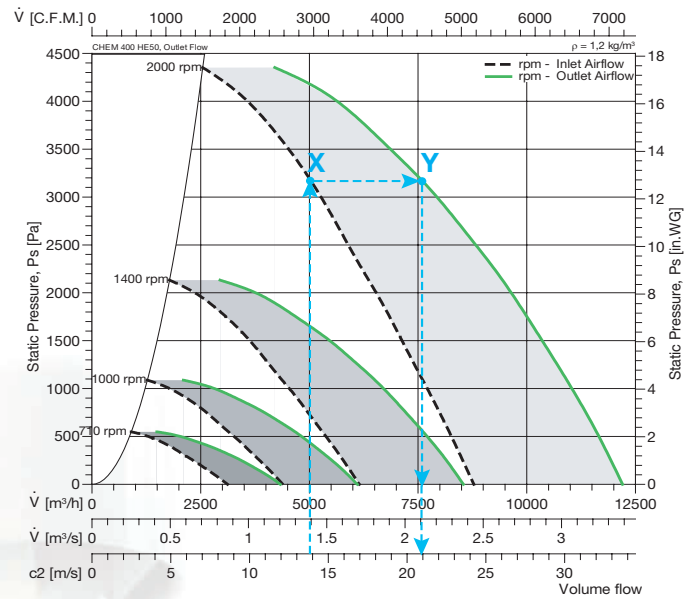

Figure 5, CHEM HE50 400 Outlet airflow curve

Selection Example

1) Inlet flow curve

Required duty point:

- ▶ Volume air flow: 5,000 m³/h
- ▶ Static pressure: 3,198 Pa

Using the fan curve:

Having chosen a fan with adequate performance range for the required duty point, see the figure 4, plot volume flow and pressure. At the point of intersection, the following data can be read:

- ▶ Fan Speed: 2,000 rpm
- ▶ Shaft power: 14.45 kW
- ▶ Nozzle outlet velocity c1: 36.8 m/s
- ▶ Sound power level: ≈ b1 = 106 dB(A)

2) Outlet flow curve

Each fan has two performance curves associated with each rpm: the black curve is the fan inlet airflow curve and the green curve directly to the right is the windband outlet airflow curve. These curves have been connected with shading in grey color.

- ▶ Determining windband outlet volume, see the figure 5;
 - Find the duty point. Draw a horizontal line to the right from "X" to the green curve "Y".
 - The windband outlet volume is determined by "Y", so the windband outlet volume is 7,540 m³/h.
- ▶ Windband outlet average velocity c2 can be read by using the windband outlet volume: 20.8 m/s
- ▶ Entrainment ratio: Windband outlet volume / Fan inlet volume = 7,540 (m³/h) / 5,000 (m³/h) = 151%

Sound Levels

In order to make possible an assessment of sound projection adequate to the human ear the A-assessed description of sound levels has been chosen. The ascertaining of the sound power level follows the reverberant room method according to AMCA 300. The sound power levels shown on each performance curve, outlet LwoA, refer to the overall sound power "A-Weighted" levels. The computed sound power levels were converted into A-Weighted levels using adjustments to the octave band spectrum as follows:

Centre Frequency Hz	63	125	250	500	1000	2000	4000	8000
A-Weighted Adjustment dB(A)	-26.2	-16.1	-8.6	-3.2	0	+1.2	+1.0	-1.1

The overall sound pressure levels, LpoA, can be calculated from the overall sound power levels as follows:

1) Free Field Conditions: $L_{poA} = L_{woA} - (20 \log_{10} d) - 11$

2) Room Conditions: $L_{poA} = L_{woA} - (20 \log_{10} d) - 7$

Where: d = distance from fan in meters

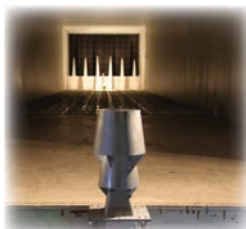

Laboratory Exhaust System

- › **Bypass Air (Q_B)**
Ambient air that is drawn through the bypass air plenum and mixed with the lab exhaust to increase dilution and plume rise. Bypass air is primarily used in variable volume applications to maintain a constant discharge volume but can also be used to increase overall exhaust volume and dilution.
- › **Dilution Ratio (D.R.)**
The ratio of the total fan outlet volume to the lab exhaust volume. (Total Volume / Lab Exhaust Air Volume). Value includes any additional bypass air in the calculation.
- › **Entrainment Air (Q_E)**
Air that is entrained (induced flow) through the windband and fan housing, mixed with the laboratory exhaust to increase the dilution ratio and plume rise.
- › **Entrainment Ratio (E.R.)**
The ratio of the total fan outlet volume to the fan inlet volume. (Total Volume / Fan Inlet Volume).
- › **Total Airflow (Q_T)**
The total airflow exiting the windband including fume exhaust, bypass air, and entrainment air. (See diagram to right).

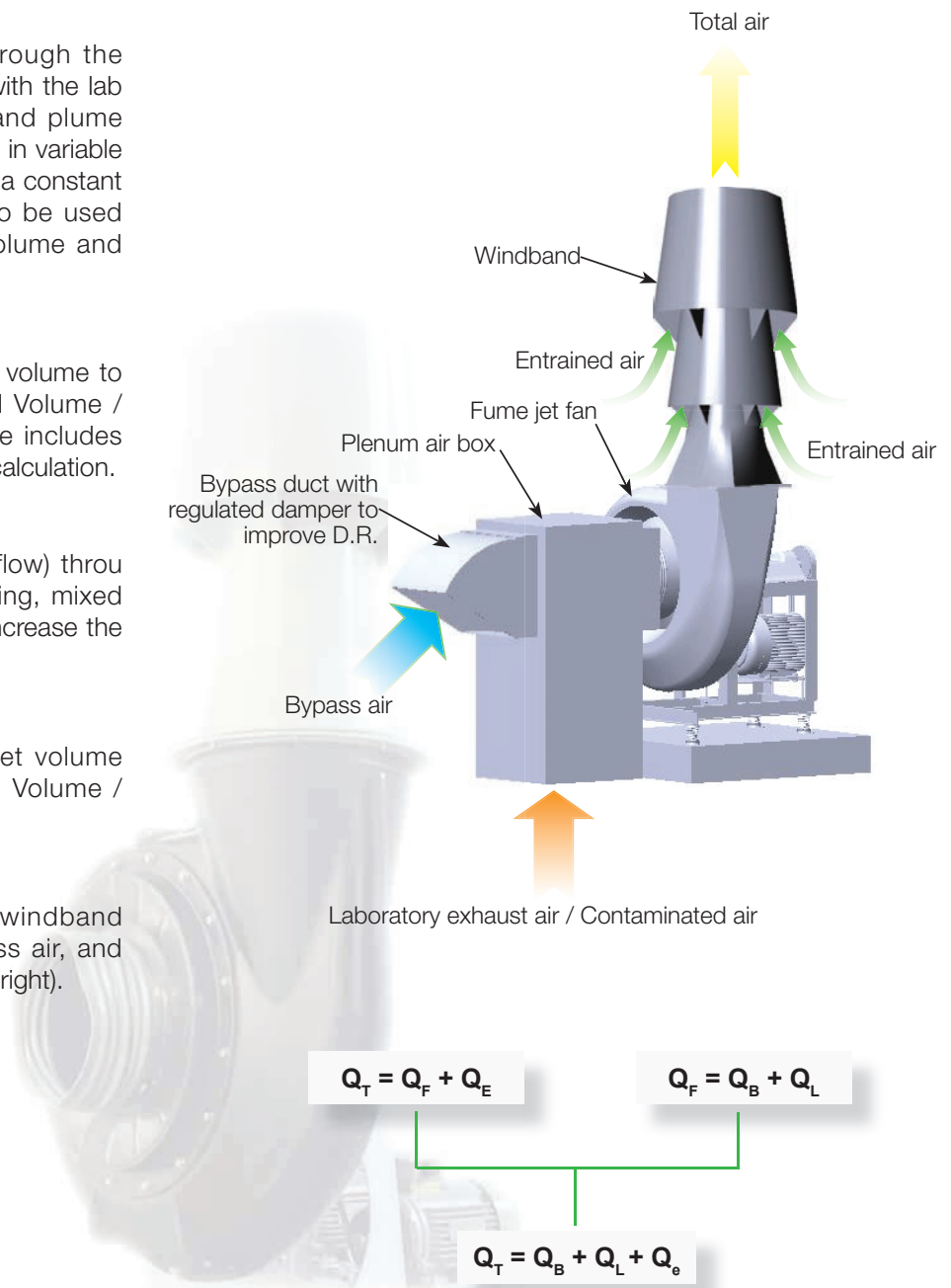

Dilution Ratio:

$$D.R = Q_T / Q_L$$

Entrainment Ratio:

$$E.R = Q_T / Q_F$$

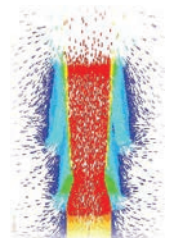

Effective Plume Height Calculation

When studying laboratory exhaust design issues, it is important to consider effective stack height. This is the physical height of the equipment plus the plume height. The following explains how this is calculated.

$$h_e = h_r + h_s *$$

$$h_e = [3.0 \times V \times d / U] + h_s$$

where: h_s = fan height (dimensions section of this catalog); h_r = plume rise, (m); V = stack discharge velocity, (m/s); d = effective stack diameter, (m); U^{**} = cross wind velocity [m/s]

* From ASHRAE Laboratory Design Guide, Equation 9-2

** Plume rises shown on performance pages are calculated with a 10 mph (4.47 m/s) crosswind.

Pressure Loss and Effective Plume Height Selection

Example:

Flow volume at 5,000 m³/h with system static pressure 3,198 pa. Minimal height from floor is 9.0 meter. Max. fan rpm at 2000.

- 1) Refer to the Wolter's CHEMCO fan curve, select a fan to meet the above specification.
- 2) Base on fan curve CHEM HE50 400 can perform the job.
- 3) Fan data: CHEM HE50 400 with RPM at 2,000, 14.45kW shaft power;
- 4) Refer to graph "Effective Plume Rise h_r - HE50 Series, Fan Sizes 200 to 400" on page 28. From 5,000 m³/h intersect size 400 curve result $h_r = 6.915$ m.
- 5) Refer to Wolter's CHEMCO Fume Jet dimensions chart for CHEM HE50 400 total height from floor level:
 $h_s = 2.434$ m

Total effective plume height $h_e = 6.915 + 2.434 = 9.349$ meters.

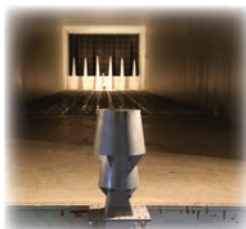
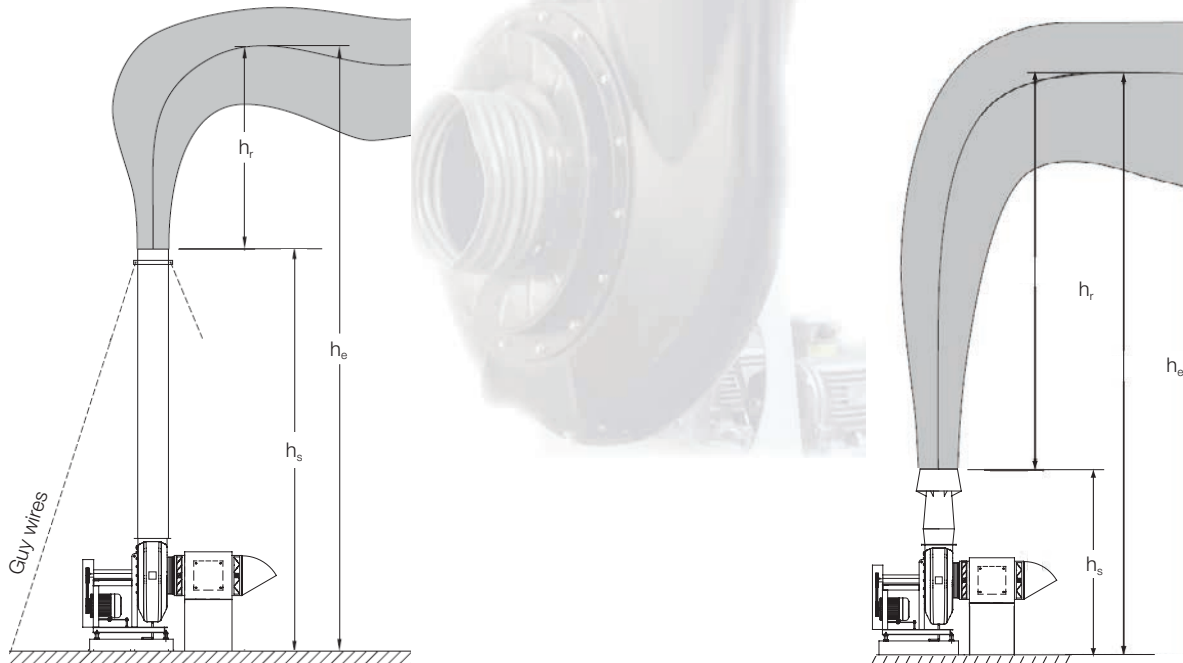



Performance Curve

CHEM HS30 200 CHEM HE30 200



HS 30 Series

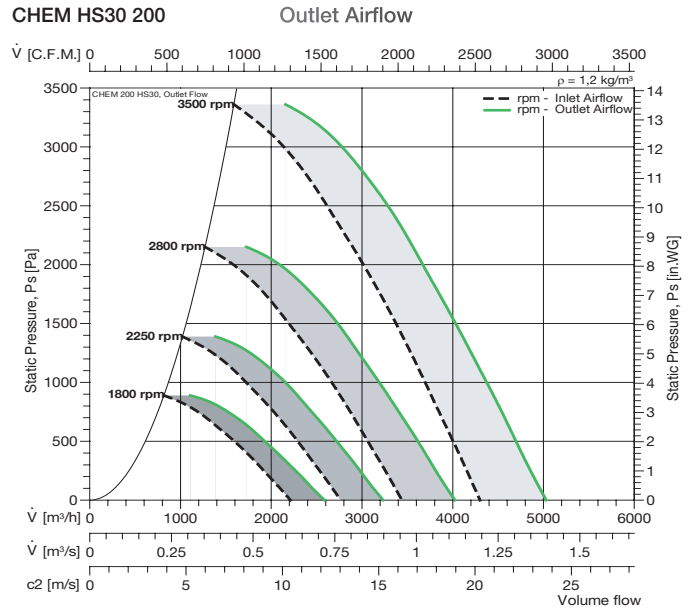
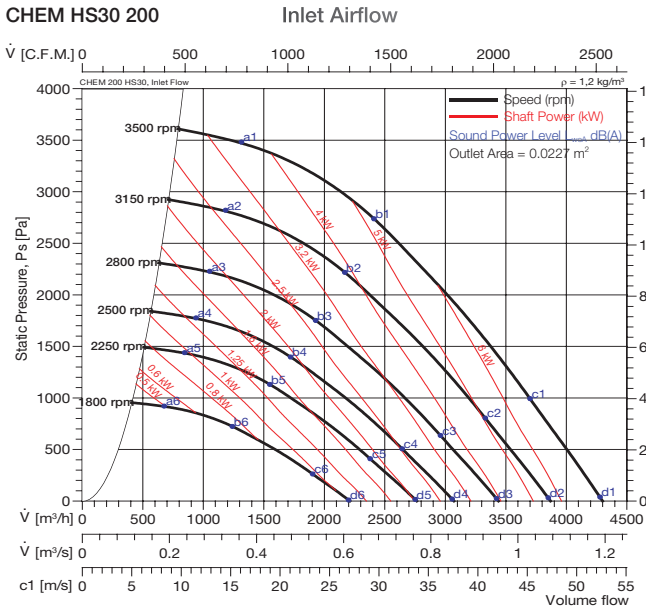

HE 30 Series

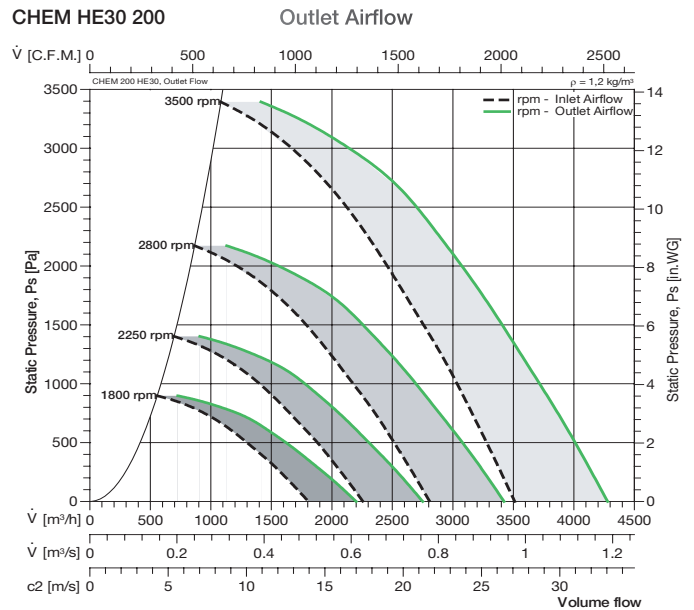
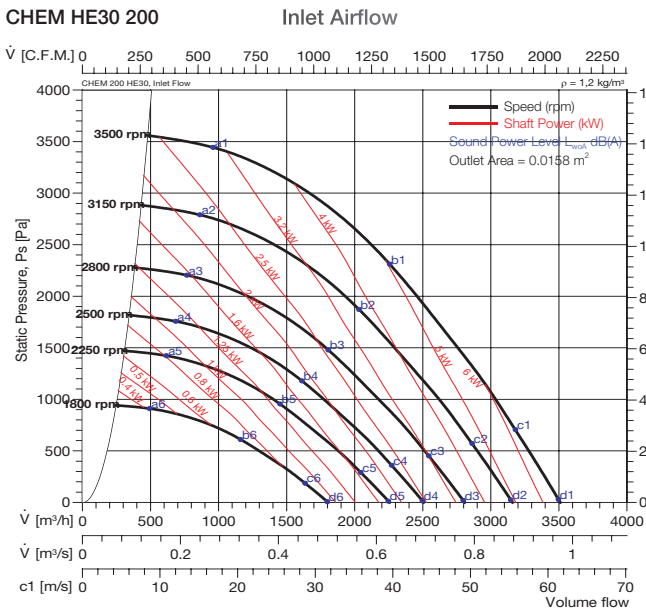

The A-weighted Sound Power Levels

Lwo(A)	a1	b1	c1	d1	a2	b2	c2	d2	a3	b3	c3	d3	a4	b4	c4	d4	a5	b5	c5	d5	a6	b6	c6	d6
HS30	108	110	111	111	105	107	108	109	102	103	105	106	98	99	101	102	95	96	98	99	88	89	91	92
HE30	108	107	108	109	105	104	105	106	101	101	102	102	97	97	98	98	94	94	95	95	87	87	88	89

Fan test laboratory AMCA 210, 260 & 300. Performance certified is for installation type C - Ducted inlet, Free outlet. Power rating (kW) does not include transmission losses. Performance ratings do not include the effects of cross winds. Performance ratings do not include the effects of appurtenances (accessories).

The A-weighted sound ratings shown have been calculated per AMCA International Standard 301. Values shown are for outlet LwoA sound power levels for installation Type C: ducted inlet, free outlet.



Performance Curve

CHEM HS30 225 CHEM HE30 225



HS 30 Series

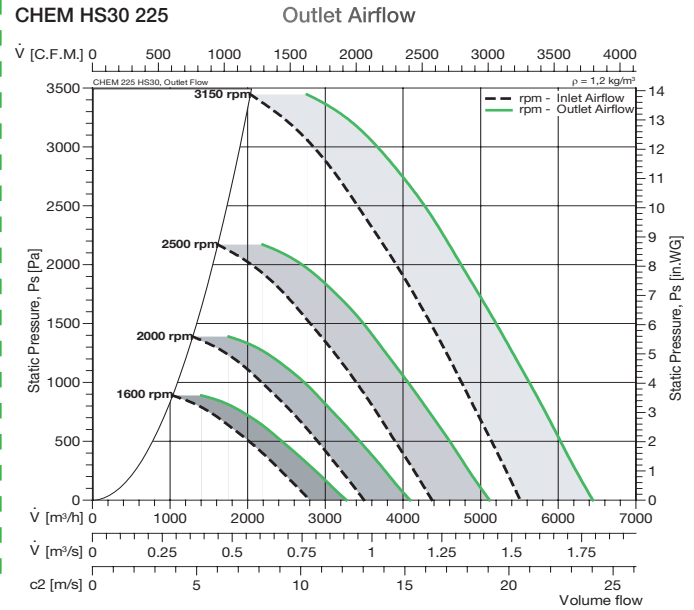
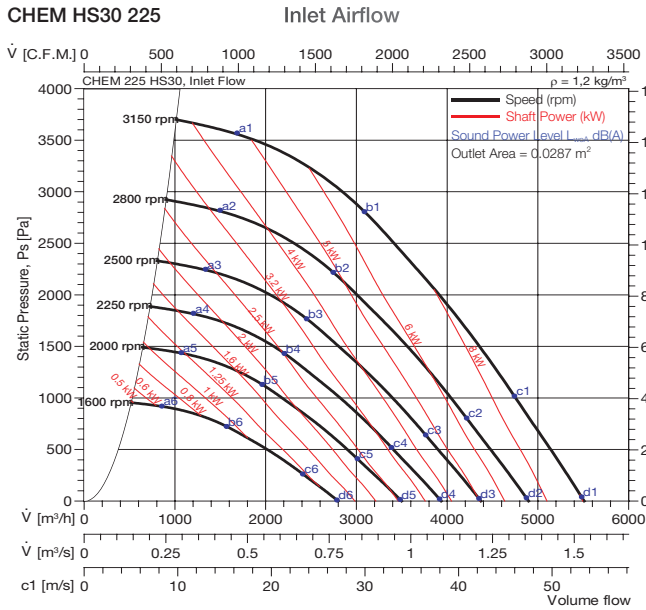

HE 30 Series

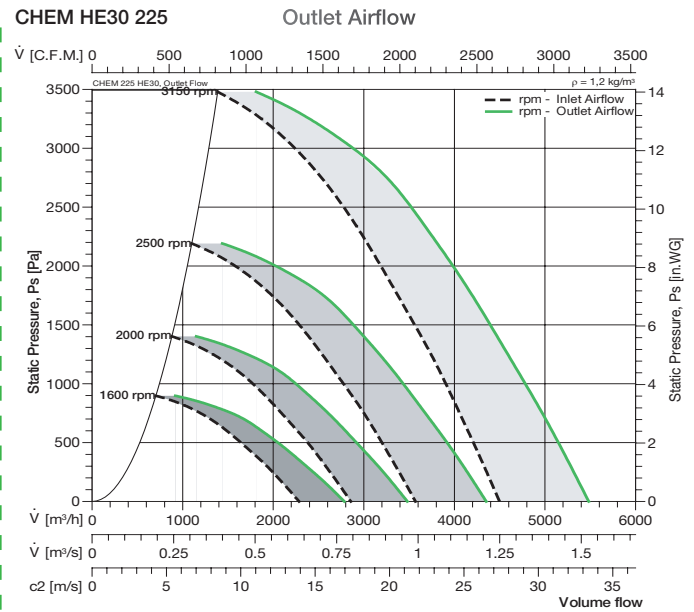
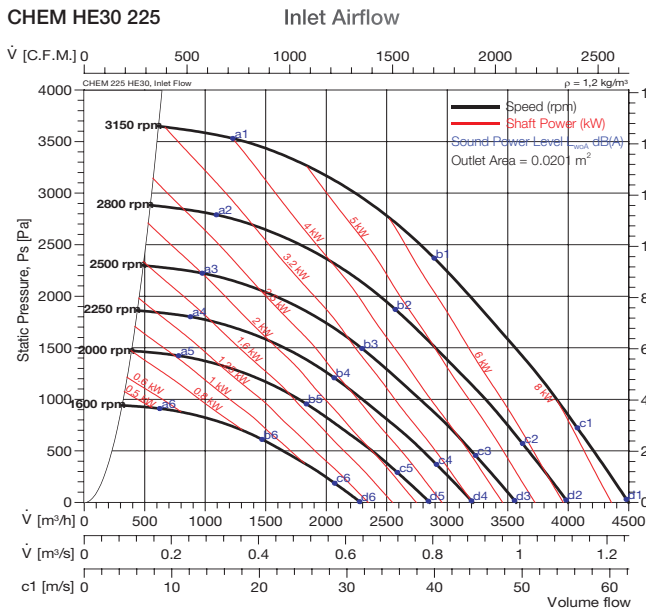

The A-weighted Sound Power Levels

	Lwo(A)	a1	b1	c1	d1	a2	b2	c2	d2	a3	b3	c3	d3	a4	b4	c4	d4	a5	b5	c5	d5	a6	b6	c6	d6
HS30	109	110	112	112	105	107	108	109	102	103	104	105	98	100	101	102	95	96	98	99	88	89	92	93	
HE30	108	108	109	109	105	104	106	106	101	101	102	102	98	97	99	99	94	94	95	95	88	87	89	89	

Fan test laboratory AMCA 210, 260 & 300. Performance certified is for installation type C - Ducted inlet, Free outlet. Power rating (kW) does not include transmission losses. Performance ratings do not include the effects of cross winds. Performance ratings do not include the effects of appurtenances (accessories).

The A-weighted sound ratings shown have been calculated per AMCA International Standard 301. Values shown are for outlet LwoA sound power levels for installation Type C: ducted inlet, free outlet.



Performance Curve

CHEM HS30 250 CHEM HE30 250



HS 30 Series

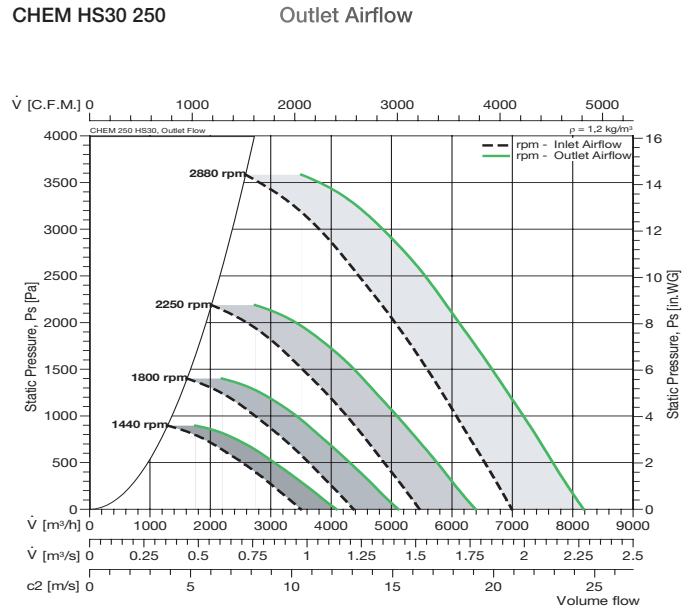
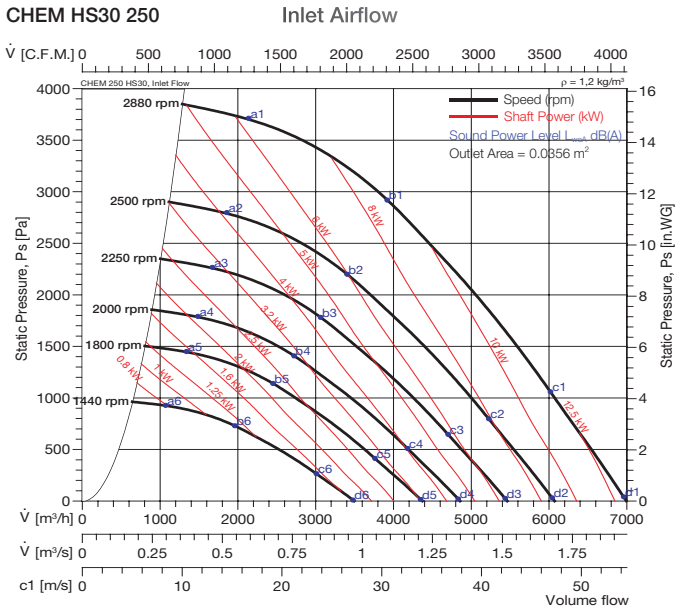

HE 30 Series

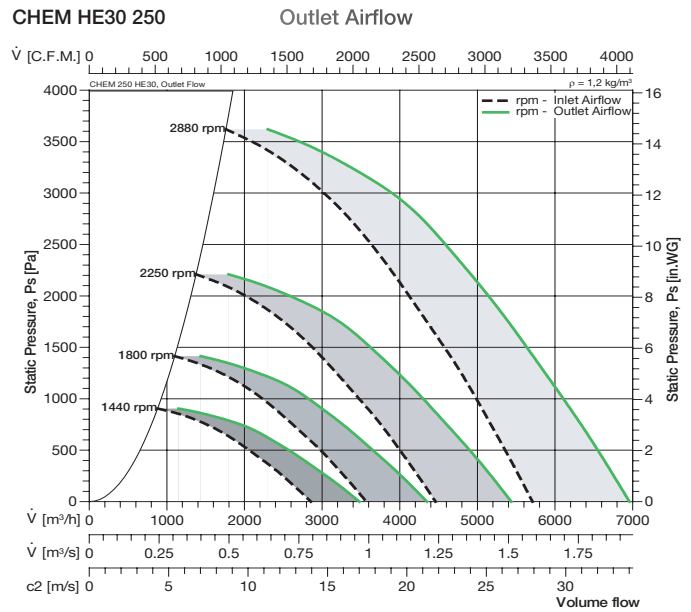
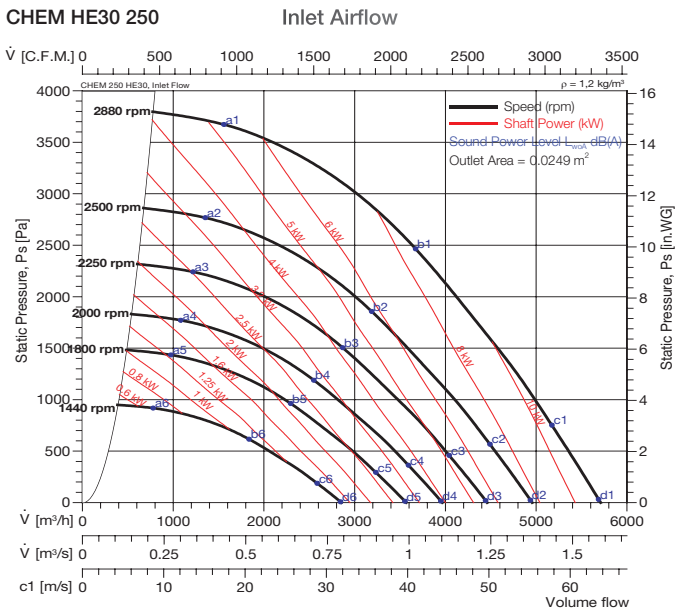

The A-weighted Sound Power Levels

Lwo(A)	a1	b1	c1	d1	a2	b2	c2	d2	a3	b3	c3	d3	a4	b4	c4	d4	a5	b5	c5	d5	a6	b6	c6	d6
HS30	110	111	113	113	105	106	108	108	102	103	105	105	98	99	101	102	95	96	98	99	88	90	92	93
HE30	109	108	110	110	104	104	105	105	101	101	102	102	98	97	98	99	94	94	95	95	88	88	89	89

Fan test laboratory AMCA 210, 260 & 300. Performance certified is for installation type C - Ducted inlet, Free outlet. Power rating (kW) does not include transmission losses. Performance ratings do not include the effects of cross winds. Performance ratings do not include the effects of appurtenances (accessories).

The A-weighted sound ratings shown have been calculated per AMCA International Standard 301. Values shown are for outlet LwoA sound power levels for installation Type C: ducted inlet, free outlet.

HE 50 Series

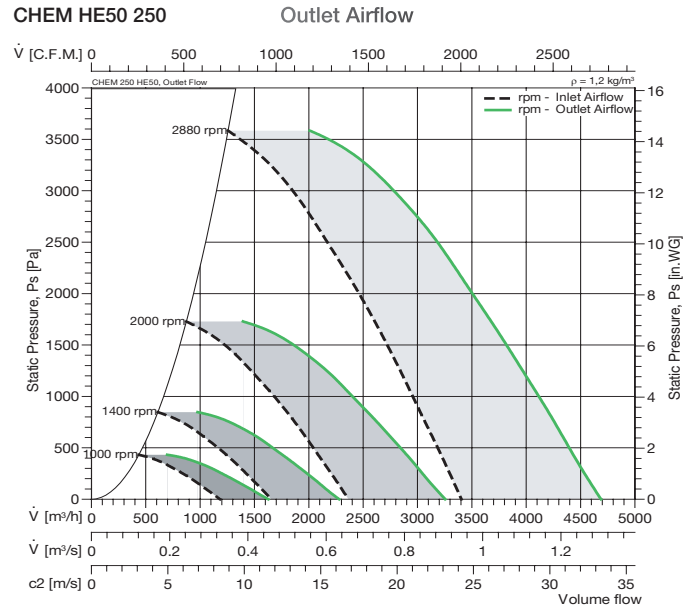
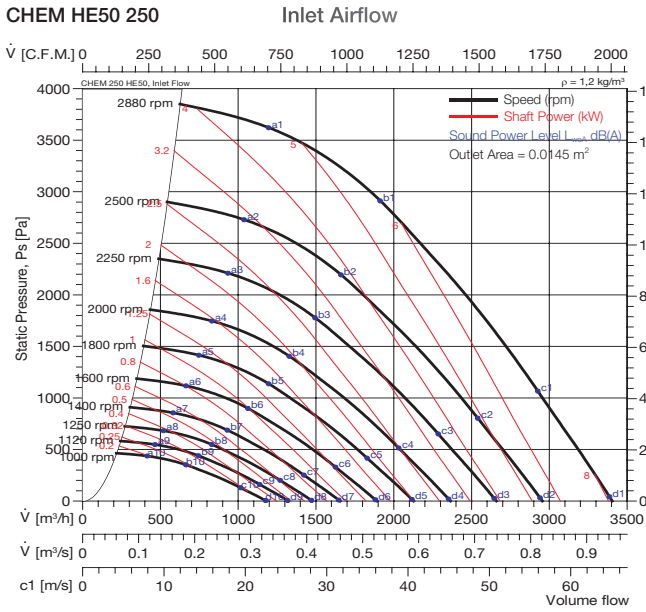

HDE 90 Series

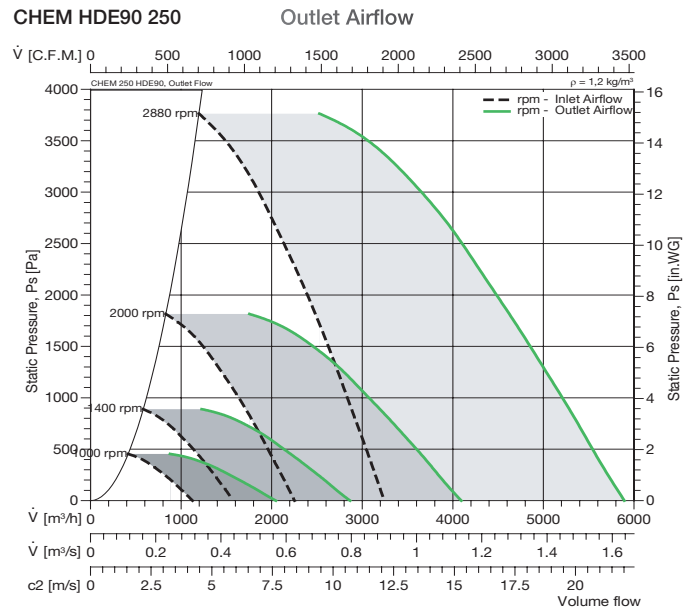
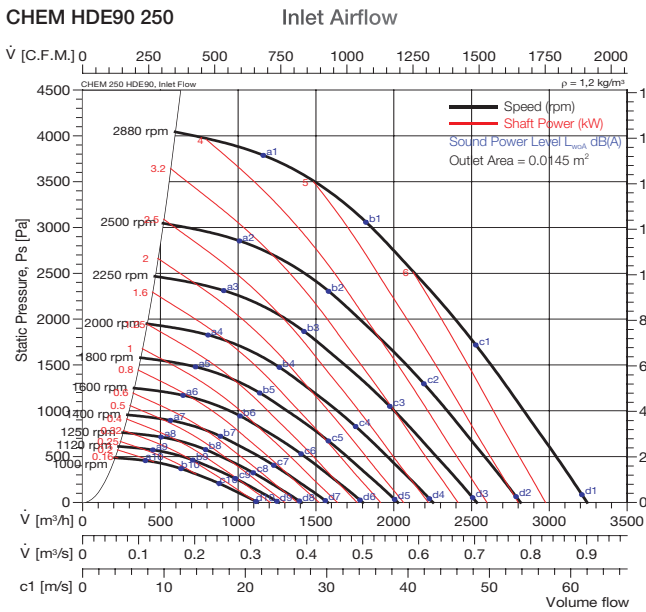

The A-weighted Sound Power Levels

Lwo(A)	a1	b1	c1	d1	a2	b2	c2	d2	a3	b3	c3	d3	a4	b4	c4	d4	a5	b5	c5	d5	a6	b6	c6	d6
HE50	110	110	109	109	106	105	105	105	103	102	102	101	99	99	98	98	96	95	95	94	92	92	91	91
HDE90	110	110	109	109	106	105	105	105	102	102	102	101	99	98	98	98	95	95	95	94	92	92	91	91

Lwo(A)	a7	b7	c7	d7	a8	b8	c8	d8	a9	b9	c9	d9	a10	b10	c10	d10	a11	b11	c11	d11	a12	b12	c12	d12
HE50	88	88	87	87	84	84	83	83	81	80	80	79	77	77	76	76	-	-	-	-	-	-	-	-
HDE90	88	88	87	87	84	84	83	83	80	80	80	79	77	76	76	76	-	-	-	-	-	-	-	-

Fan test laboratory AMCA 210, 260 & 300. Performance is for installation type C - Ducted inlet, Free outlet. Power rating (kW) does not include transmission losses. Performance ratings do not include the effects of cross winds. Performance ratings do not include the effects of appurtenances (accessories).

The A-weighted sound ratings shown have been calculated per AMCA International Standard 301. Values shown are for outlet LwoA sound power levels for installation Type C: ducted inlet, free outlet.
NB: CHEM HE50 & HDE90 is not licensed to bear the AMCA certified rating seal.



Performance Curve

CHEM HS30 280 CHEM HE30 280



HS 30 Series

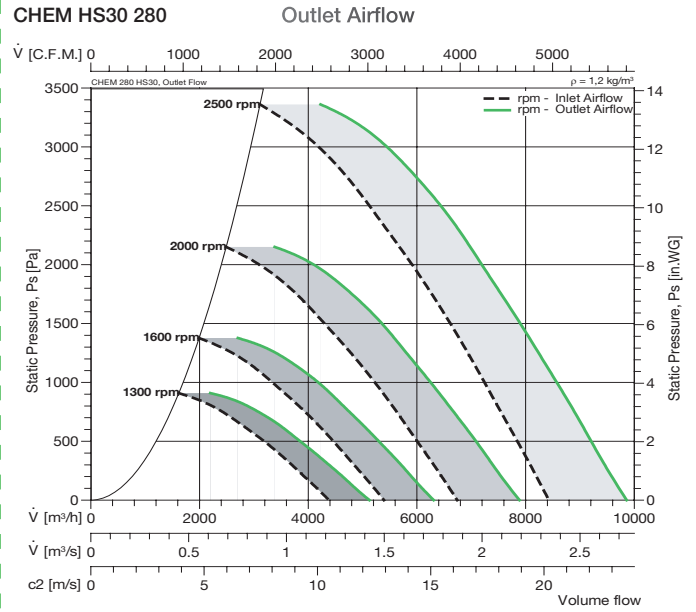
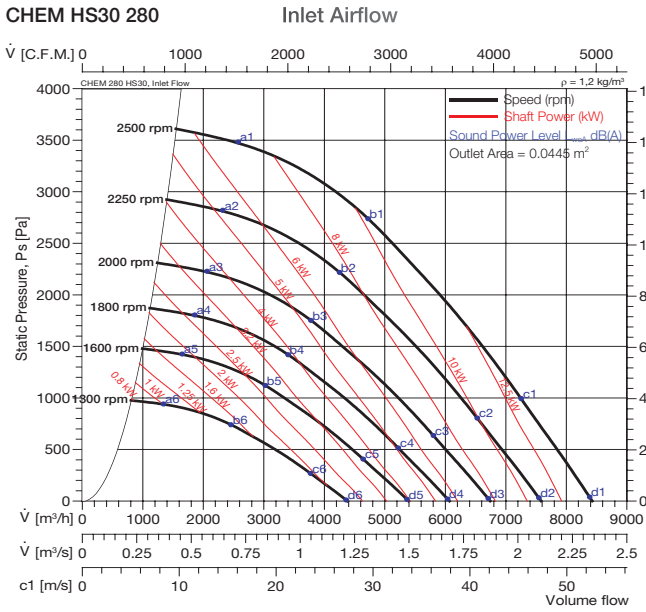

HE 30 Series

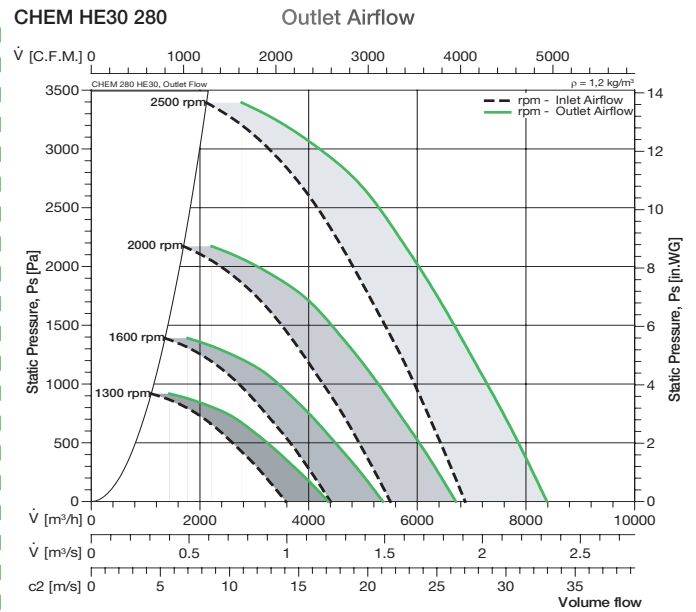
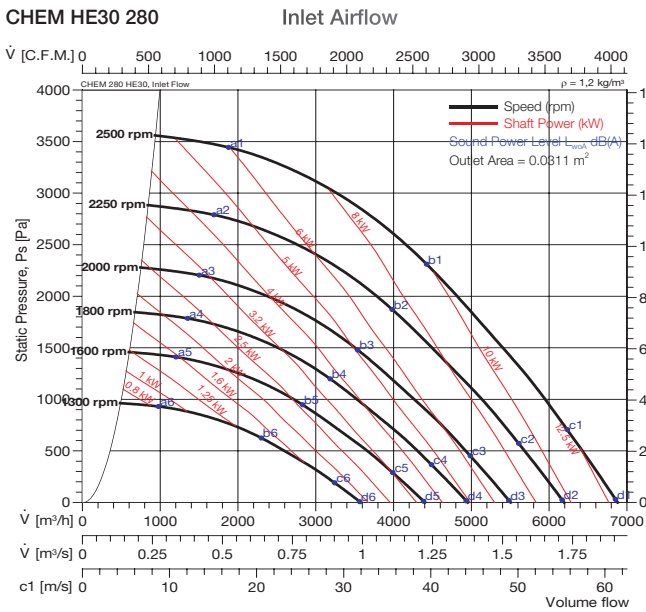

The A-weighted Sound Power Levels

Lwo(A)	a1	b1	c1	d1	a2	b2	c2	d2	a3	b3	c3	d3	a4	b4	c4	d4	a5	b5	c5	d5	a6	b6	c6	d6
HS30	108	109	111	112	105	106	108	109	101	103	105	105	98	99	101	102	95	96	98	99	88	89	92	93
HE30	108	107	108	109	104	104	105	105	101	100	102	102	98	97	99	99	94	94	95	95	87	87	89	89

Fan test laboratory AMCA 210, 260 & 300. Performance certified is for installation type C - Ducted inlet, Free outlet. Power rating (kW) does not include transmission losses. Performance ratings do not include the effects of cross winds. Performance ratings do not include the effects of appurtenances (accessories).

The A-weighted sound ratings shown have been calculated per AMCA International Standard 301. Values shown are for outlet LwoA sound power levels for installation Type C: ducted inlet, free outlet.



Performance Curve

CHEM HS30 315 CHEM HE30 315



HS 30 Series

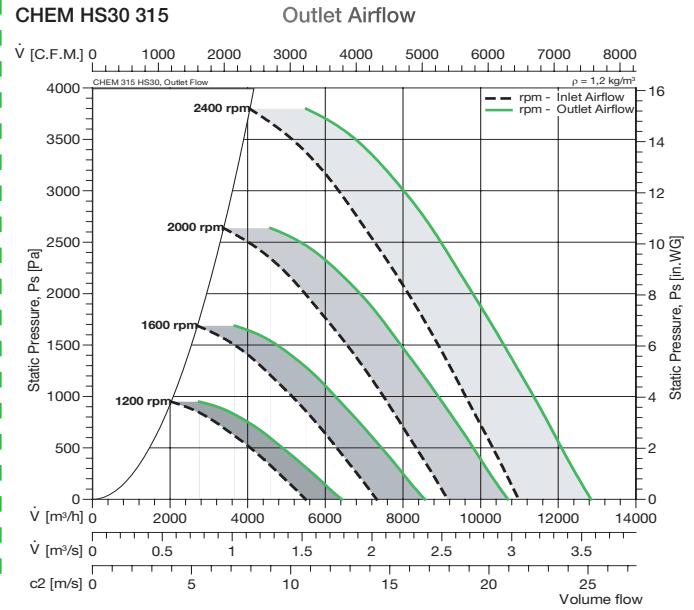
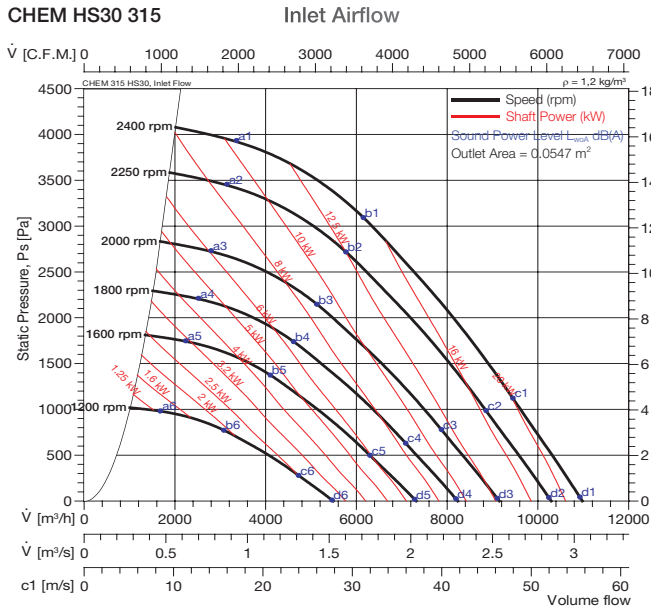

HE 30 Series

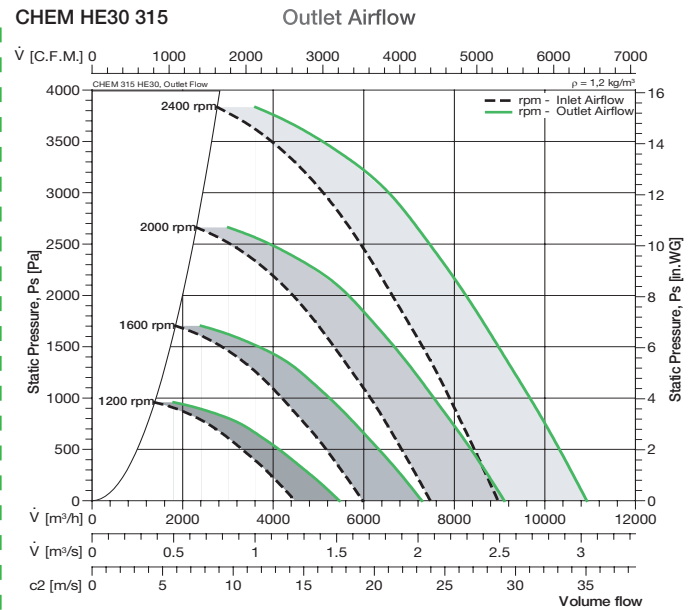
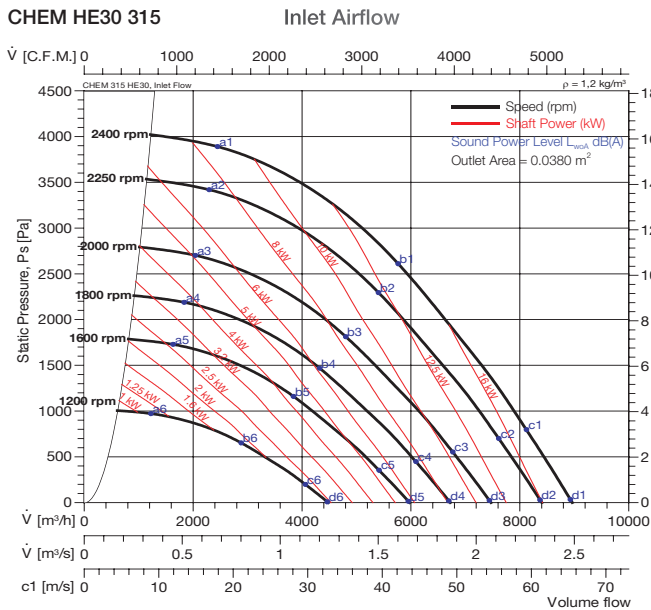

The A-weighted Sound Power Levels

Lwo(A)	a1	b1	c1	d1	a2	b2	c2	d2	a3	b3	c3	d3	a4	b4	c4	d4	a5	b5	c5	d5	a6	b6	c6	d6
HS30	110	111	113	114	108	109	111	112	105	106	108	108	101	102	104	105	98	99	101	102	88	90	92	93
HE30	109	109	110	110	107	107	108	109	104	104	105	105	101	100	102	102	97	97	98	99	88	88	89	90

Fan test laboratory AMCA 210, 260 & 300. Performance certified is for installation type C - Ducted inlet, Free outlet. Power rating (kW) does not include transmission losses. Performance ratings do not include the effects of cross winds. Performance ratings do not include the effects of appurtenances (accessories).

The A-weighted sound ratings shown have been calculated per AMCA International Standard 301. Values shown are for outlet LwoA sound power levels for installation Type C: ducted inlet, free outlet.

HE 50 Series

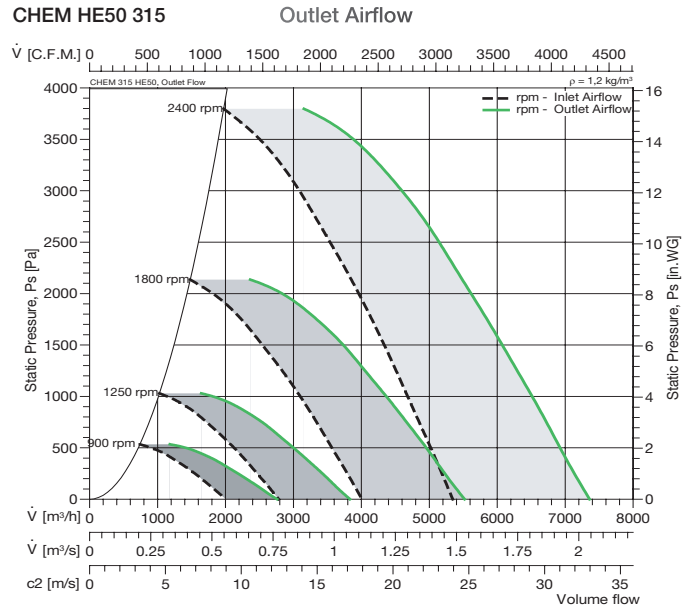
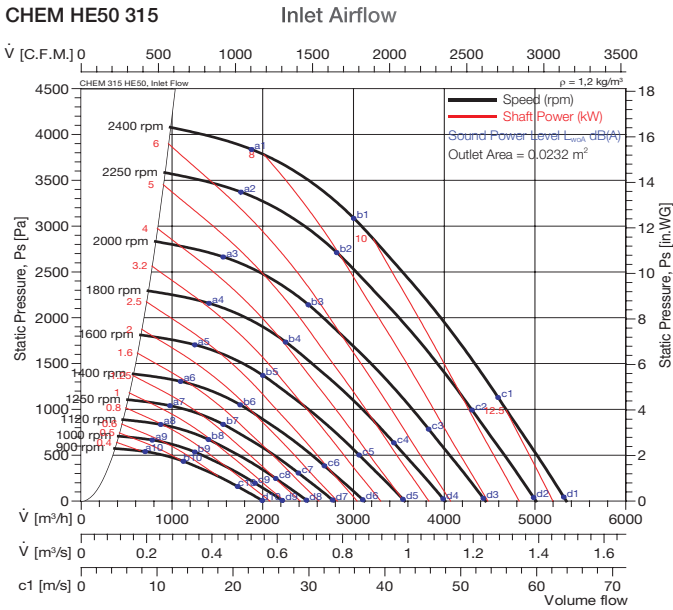

HDE 90 Series

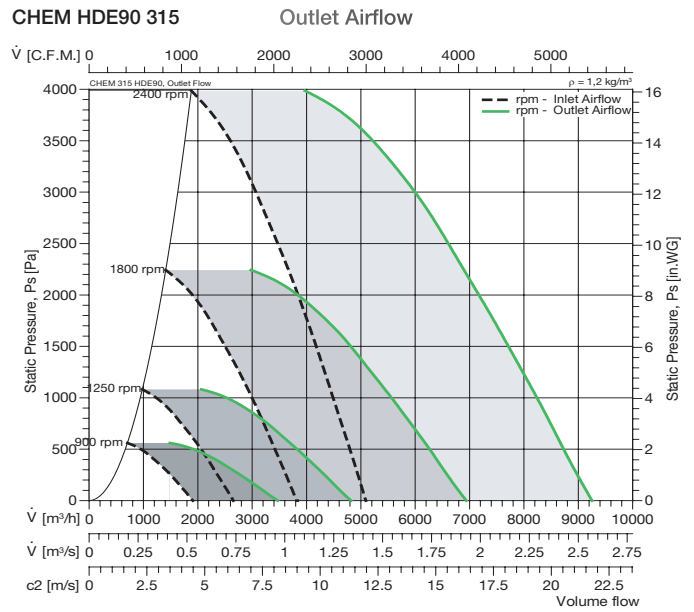
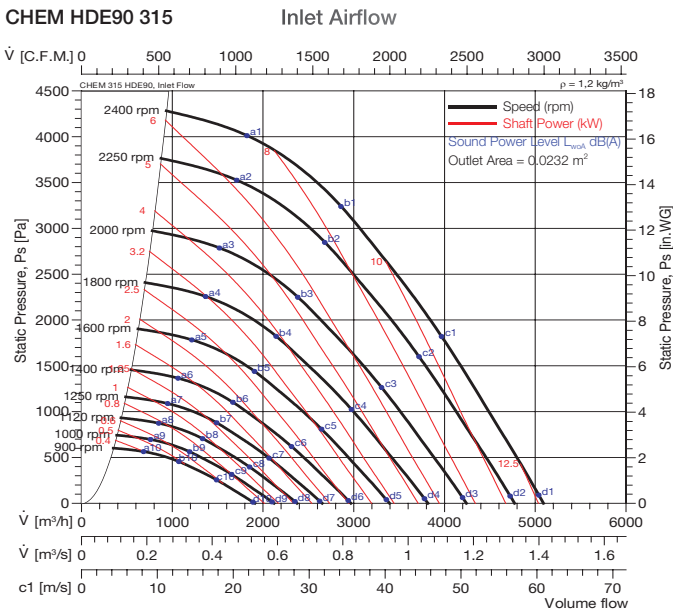

The A-weighted Sound Power Levels

Lwo(A)	a1	b1	c1	d1	a2	b2	c2	d2	a3	b3	c3	d3	a4	b4	c4	d4	a5	b5	c5	d5	a6	b6	c6	d6
HE50	111	111	110	110	109	109	108	108	105	105	104	104	102	102	101	101	99	98	98	97	94	94	93	93
HDE90	111	110	110	110	109	108	108	108	105	105	104	104	102	101	101	101	98	98	98	97	94	94	93	93

Lwo(A)	a7	b7	c7	d7	a8	b8	c8	d8	a9	b9	c9	d9	a10	b10	c10	d10	a11	b11	c11	d11	a12	b12	c12	d12
HE50	87	87	87	87	87	87	86	86	83	83	83	82	80	80	79	79	-	-	-	-	-	-	-	-
HDE90	87	87	87	87	87	86	86	86	83	83	83	82	80	80	79	79	-	-	-	-	-	-	-	-

Fan test laboratory AMCA 210, 260 & 300. Performance s for installation type C - Ducted inlet, Free outlet. Power rating (kW) does not include transmission losses. Performance ratings do not include the effects of cross winds. Performance ratings do not include the effects of appurtenances (accessories).

The A-weighted sound ratings shown have been calculated per AMCA International Standard 301. Values shown are for outlet LwoA sound power levels for installation Type C: ducted inlet, free outlet. NB: CHEM HE50 & HDE90 is not licensed to bear the AMCA certified rating seal.



Performance Curve

CHEM HS30 355 CHEM HE30 355



HS 30 Series

CHEM HS30 355

Inlet Airflow

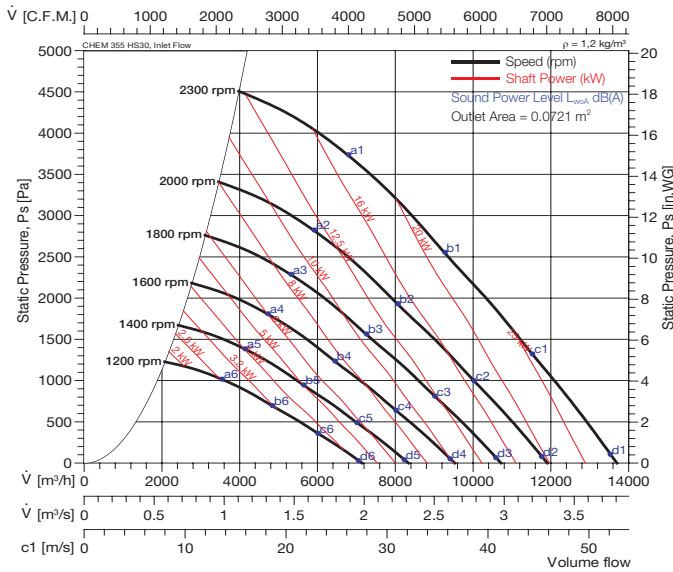

CHEM HS30 355

Outlet Airflow

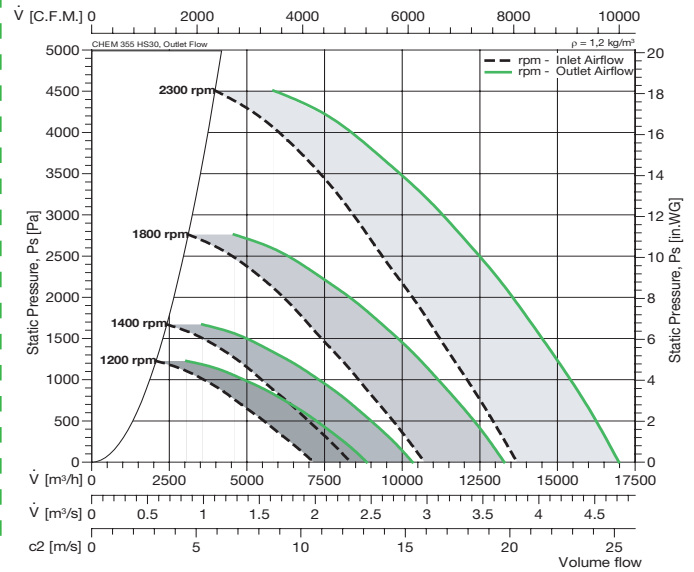

HE 30 Series

CHEM HE30 355

Inlet Airflow

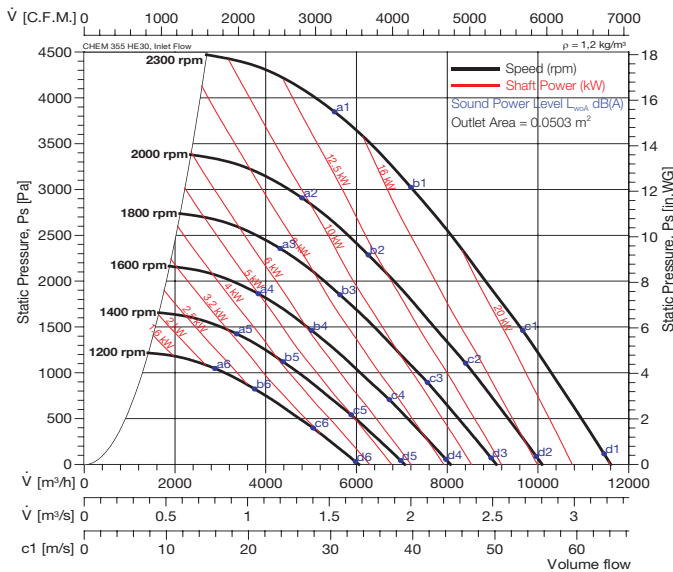

CHEM HE30 355

Outlet Airflow

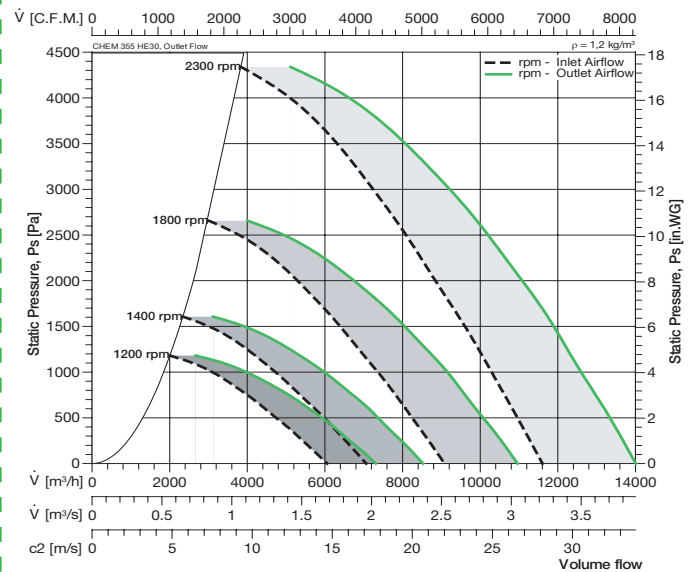

The A-weighted Sound Power Levels

Lwo(A)	a1	b1	c1	d1	a2	b2	c2	d2	a3	b3	c3	d3	a4	b4	c4	d4	a5	b5	c5	d5	a6	b6	c6	d6
HS30	108	110	113	115	104	106	109	112	101	103	106	110	100	102	105	107	97	99	102	104	90	92	95	97
HE30	106	107	110	112	102	103	106	109	99	100	103	107	97	98	102	104	94	95	99	101	89	89	92	94

Fan test laboratory AMCA 210, 260 & 300. Performance certified is for installation type C - Ducted inlet, Free outlet. Power rating (kW) does not include transmission losses. Performance ratings do not include the effects of cross winds. Performance ratings do not include the effects of appurtenances (accessories).

The A-weighted sound ratings shown have been calculated per AMCA International Standard 301. Values shown are for outlet LwoA sound power levels for installation Type C: ducted inlet, free outlet.



HE 50 Series

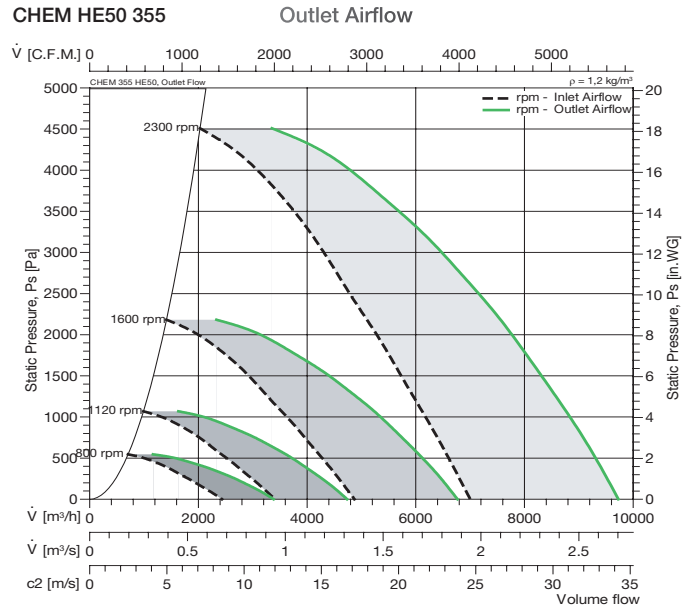
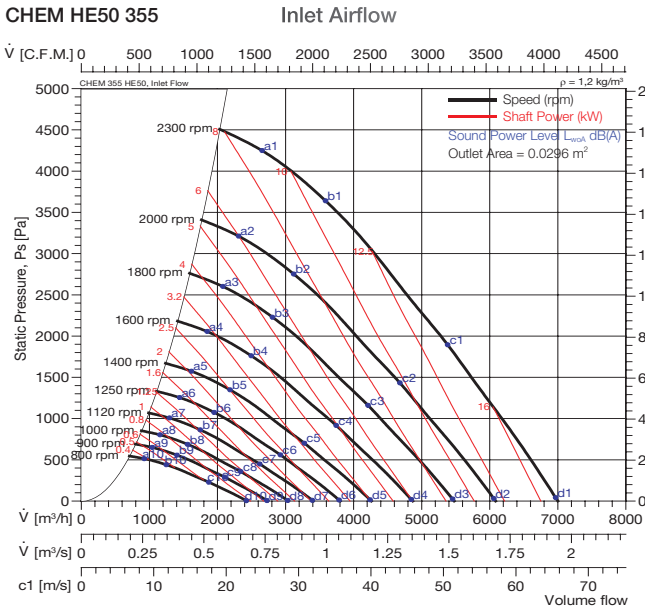

HDE 90 Series

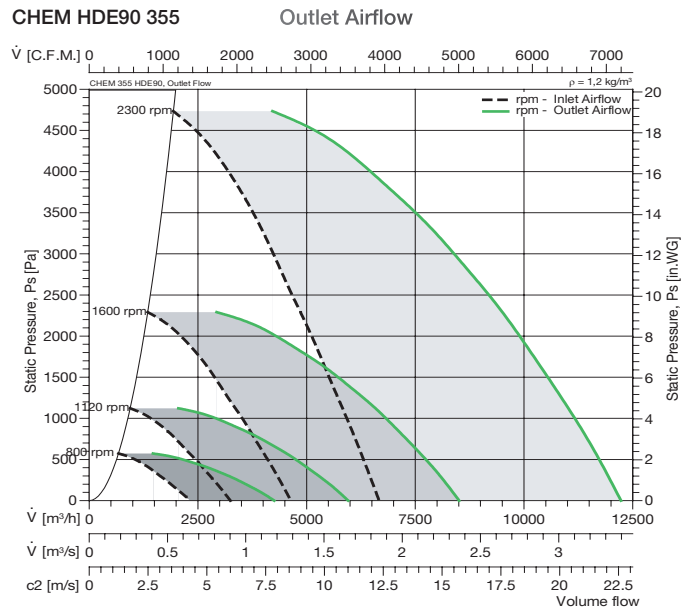
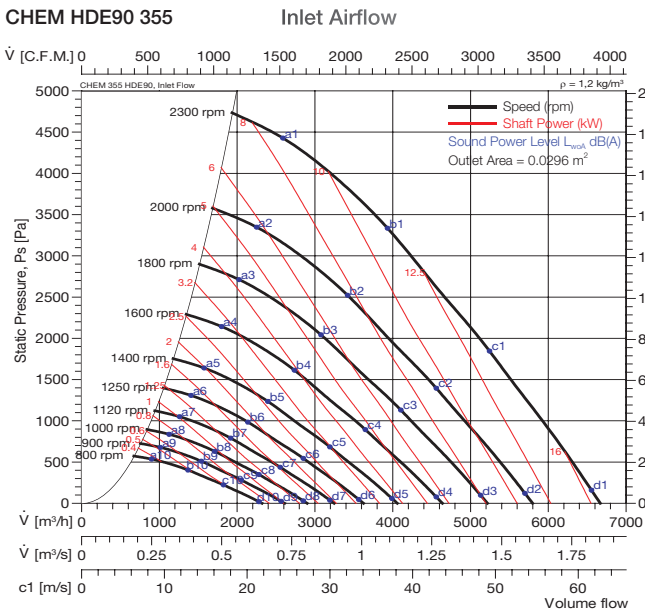

The A-weighted Sound Power Levels

Lwo(A)	a1	b1	c1	d1	a2	b2	c2	d2	a3	b3	c3	d3	a4	b4	c4	d4	a5	b5	c5	d5	a6	b6	c6	d6
HE50	107	106	105	104	103	102	101	101	100	99	98	99	98	97	96	96	95	94	93	93	90	90	89	89
HDE90	106	106	105	104	103	102	101	101	100	99	99	99	98	97	97	96	95	94	93	93	90	90	89	89

Lwo(A)	a7	b7	c7	d7	a8	b8	c8	d8	a9	b9	c9	d9	a10	b10	c10	d10	a11	b11	c11	d11	a12	b12	c12	d12
HE50	87	87	86	86	85	84	83	83	82	81	81	80	79	78	78	78	-	-	-	-	-	-	-	-
HDE90	87	87	86	86	84	84	83	83	82	81	81	80	79	78	78	77	-	-	-	-	-	-	-	-

Fan test laboratory AMCA 210, 260 & 300. Performance s for installation type C - Ducted inlet, Free outlet. Power rating (kW) does not include transmission losses. Performance ratings do not include the effects of cross winds. Performance ratings do not include the effects of appurtenances (accessories).

The A-weighted sound ratings shown have been calculated per AMCA International Standard 301. Values shown are for outlet LwoA sound power levels for installation Type C: ducted inlet, free outlet.
 NB: CHEM HE50 & HDE90 is not licensed to bear the AMCA certified rating seal.



Performance Curve

CHEM HS30 400 CHEM HE30 400



HS 30 Series

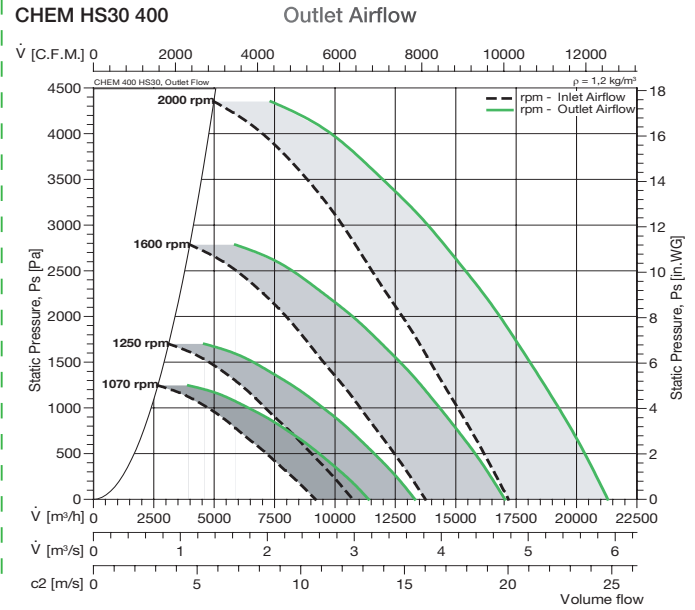
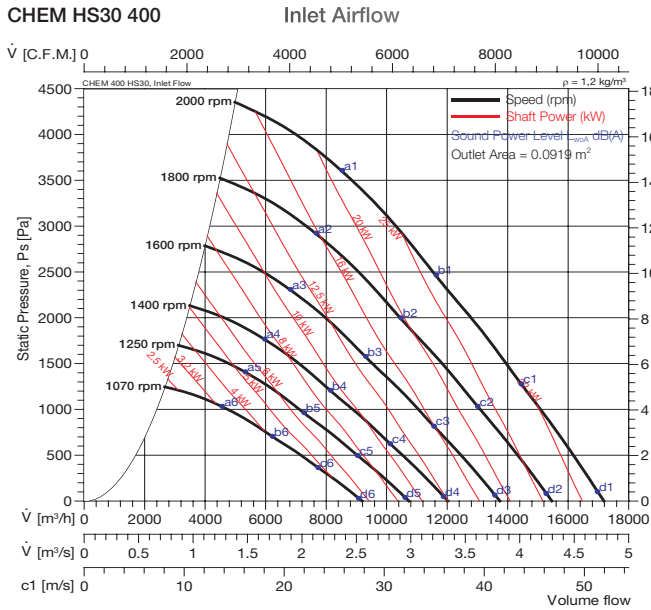

HE 30 Series

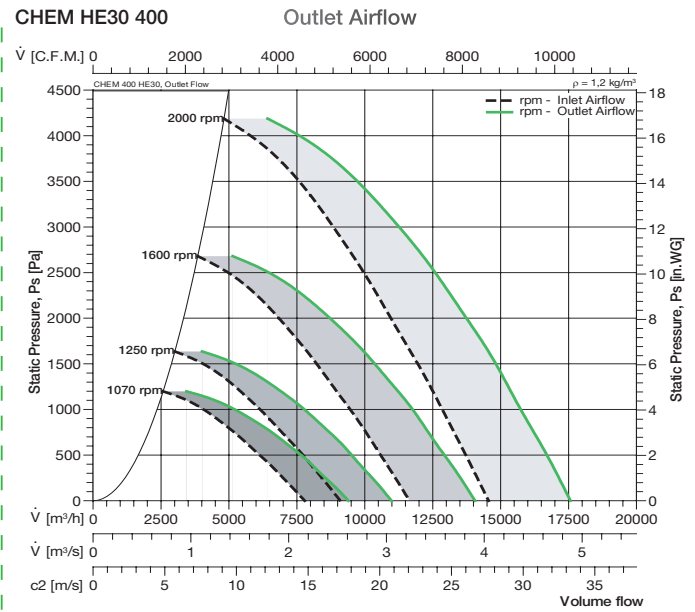
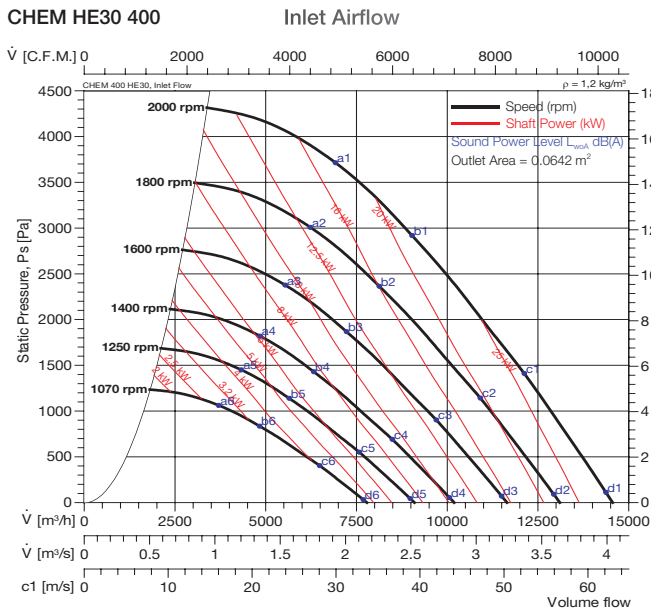

The A-weighted Sound Power Levels

Lwo(A)	a1	b1	c1	d1	a2	b2	c2	d2	a3	b3	c3	d3	a4	b4	c4	d4	a5	b5	c5	d5	a6	b6	c6	d6
HS30	108	110	112	116	105	107	109	113	102	104	106	111	100	103	106	108	95	97	99	102	91	93	95	98
HE30	106	107	110	113	103	104	107	110	100	101	103	108	98	99	103	105	93	94	96	99	89	90	92	95

Fan test laboratory AMCA 210, 260 & 300. Performance certified is for installation type C - Ducted inlet, Free outlet. Power rating (kW) does not include transmission losses. Performance ratings do not include the effects of cross winds. Performance ratings do not include the effects of appurtenances (accessories).

The A-weighted sound ratings shown have been calculated per AMCA International Standard 301. Values shown are for outlet LwoA sound power levels for installation Type C: ducted inlet, free outlet.



HE 50 Series

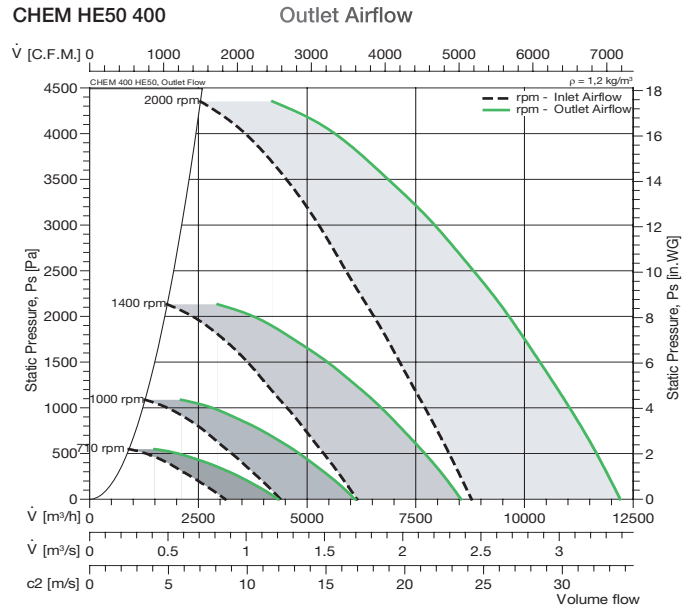
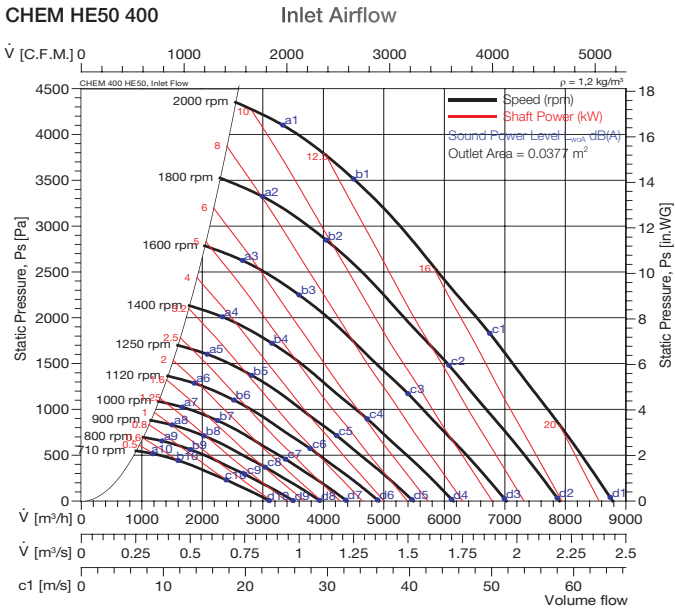

HDE 90 Series

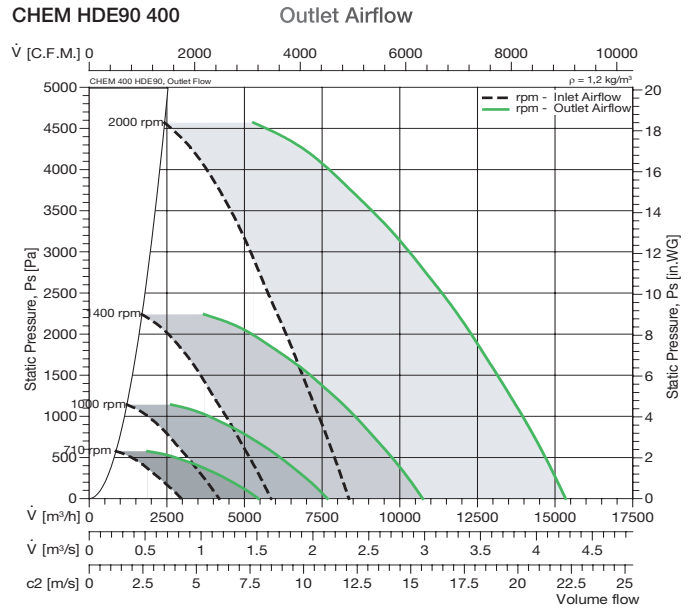
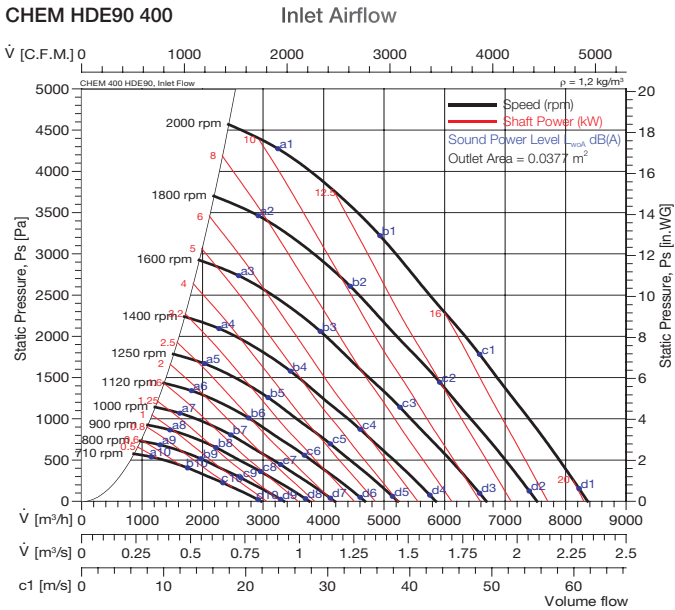

The A-weighted Sound Power Levels

Lwo(A)	a1	b1	c1	d1	a2	b2	c2	d2	a3	b3	c3	d3	a4	b4	c4	d4	a5	b5	c5	d5	a6	b6	c6	d6
HE50	107	106	105	105	104	103	102	102	101	100	99	100	99	98	97	97	94	93	93	92	91	90	90	90
HDE90	106	106	105	105	104	103	102	102	101	100	99	100	99	98	97	97	94	93	93	92	91	90	90	90

Lwo(A)	a7	b7	c7	d7	a8	b8	c8	d8	a9	b9	c9	d9	a10	b10	c10	d10	a11	b11	c11	d11	a12	b12	c12	d12
HE50	88	88	87	87	86	85	84	84	83	82	81	81	80	79	79	79	-	-	-	-	-	-	-	-
HDE90	88	88	87	87	85	85	84	84	82	82	82	81	79	79	79	78	-	-	-	-	-	-	-	-

Fan test laboratory AMCA 210, 260 & 300. Performance s for installation type C - Ducted inlet, Free outlet. Power rating (kW) does not include transmission losses. Performance ratings do not include the effects of cross winds. Performance ratings do not include the effects of appurtenances (accessories).

The A-weighted sound ratings shown have been calculated per AMCA International Standard 301. Values shown are for outlet LwoA sound power levels for installation Type C: ducted inlet, free outlet.
NB: CHEM HE50 & HDE90 is not licensed to bear the AMCA certified rating seal.



Performance Curve

CHEM HS30 450 CHEM HE30 450



HS 30 Series

CHEM HS30 450

Inlet Airflow

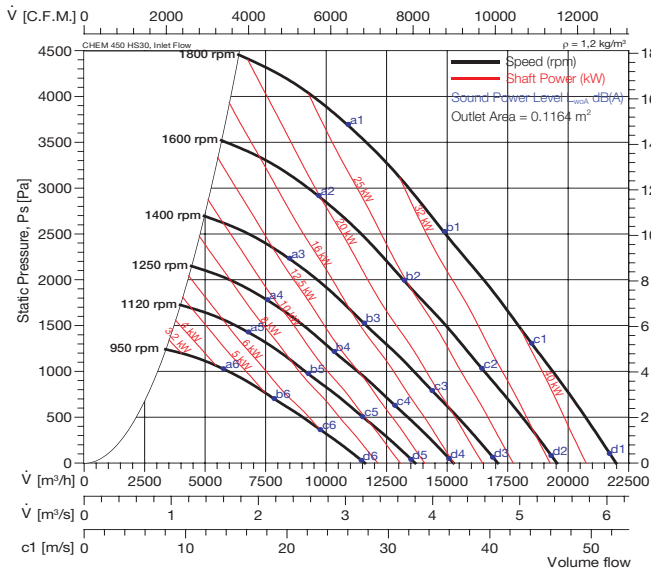

CHEM HS30 450

Outlet Airflow

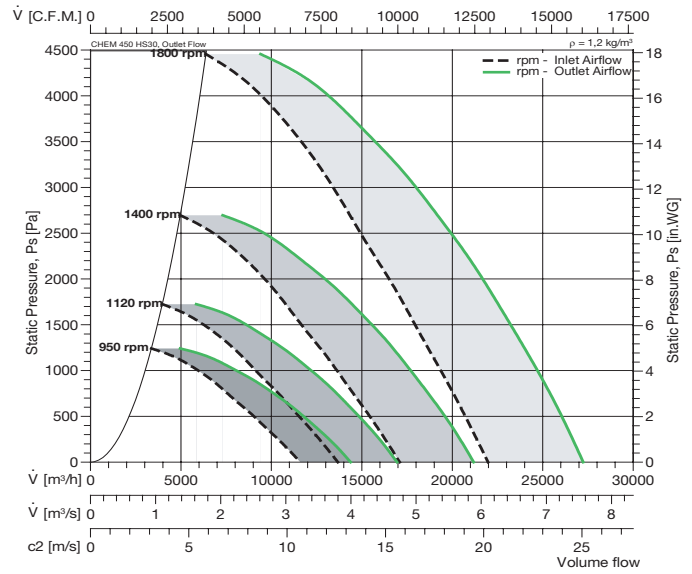

HE 30 Series

CHEM HE30 450

Inlet Airflow

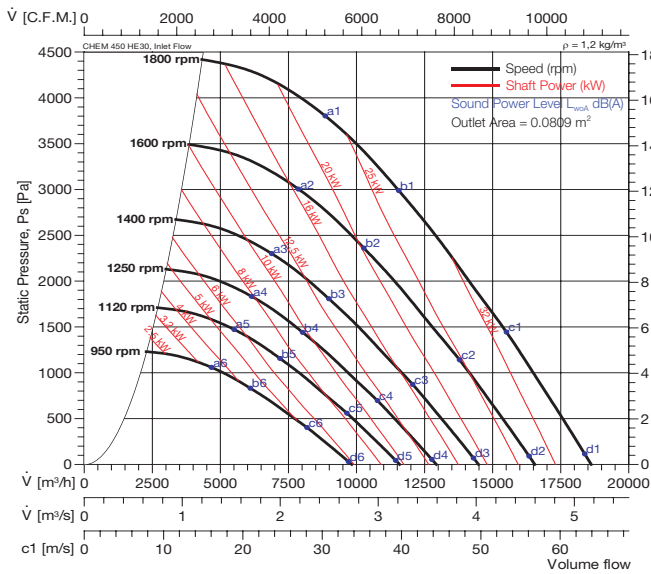

CHEM HE30 450

Outlet Airflow

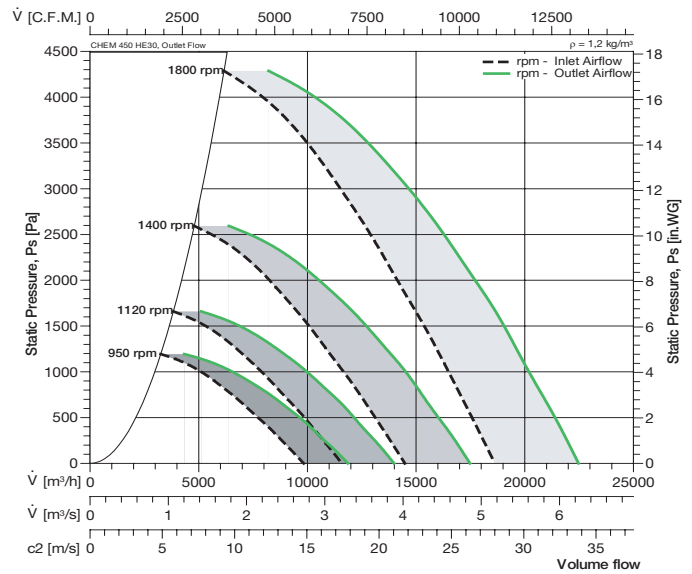

The A-weighted Sound Power Levels

Lwo(A)	a1	b1	c1	d1	a2	b2	c2	d2	a3	b3	c3	d3	a4	b4	c4	d4	a5	b5	c5	d5	a6	b6	c6	d6
HS30	109	111	113	117	105	107	110	114	102	104	106	112	99	100	103	105	96	98	100	103	92	94	96	99
HE30	107	108	110	114	104	104	107	111	100	101	103	108	97	98	100	102	94	95	97	99	90	91	93	95

Fan test laboratory AMCA 210, 260 & 300. Performance certified is for installation type C - Ducted inlet, Free outlet. Power rating (kW) does not include transmission losses. Performance ratings do not include the effects of cross winds. Performance ratings do not include the effects of appurtenances (accessories).

The A-weighted sound ratings shown have been calculated per AMCA International Standard 301. Values shown are for outlet LwoA sound power levels for installation Type C: ducted inlet, free outlet.



HE 50 Series

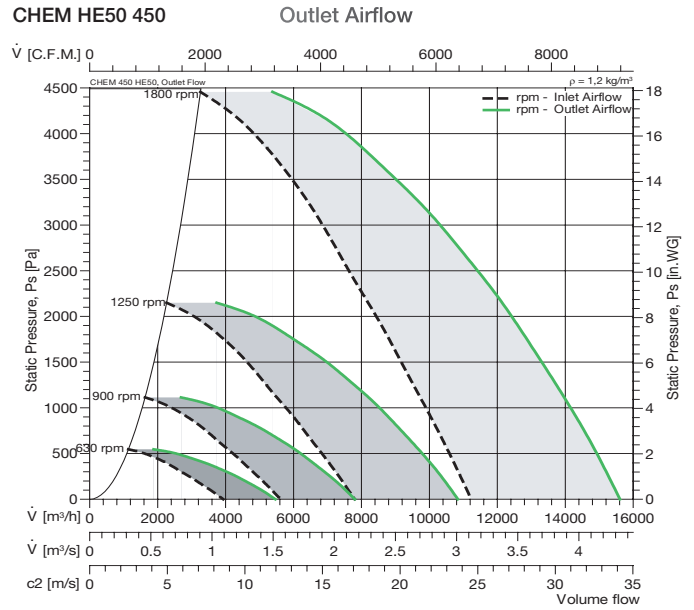
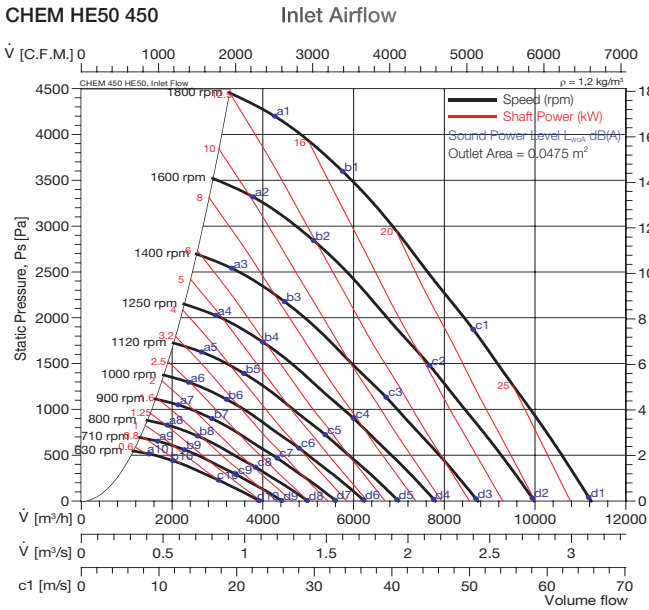

HDE 90 Series

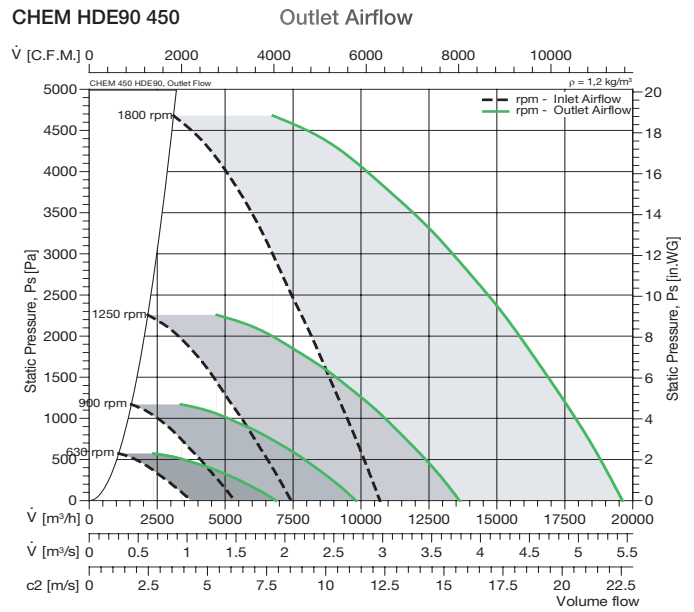
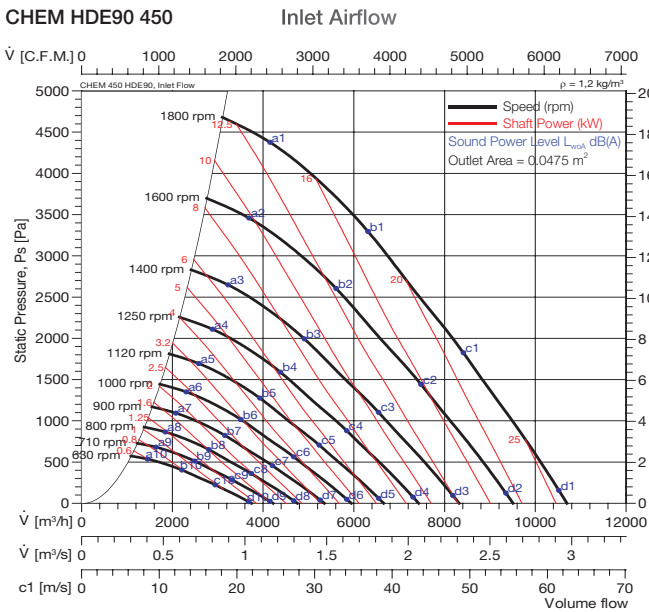

The A-weighted Sound Power Levels

Lwo(A)	a1	b1	c1	d1	a2	b2	c2	d2	a3	b3	c3	d3	a4	b4	c4	d4	a5	b5	c5	d5	a6	b6	c6	d6
HE50	107	107	106	106	104	103	103	103	101	100	99	100	98	97	96	96	95	94	93	93	92	91	91	90
HDE90	107	107	106	106	104	103	103	103	100	100	99	100	97	97	96	96	95	94	93	93	92	91	91	90

Lwo(A)	a7	b7	c7	d7	a8	b8	c8	d8	a9	b9	c9	d9	a10	b10	c10	d10	a11	b11	c11	d11	a12	b12	c12	d12
HE50	89	89	88	88	86	86	85	85	83	83	82	82	80	80	79	79	-	-	-	-	-	-	-	-
HDE90	89	88	88	88	86	86	85	85	83	83	82	82	80	80	79	79	-	-	-	-	-	-	-	-

Fan test laboratory AMCA 210, 260 & 300. Performance s for installation type C - Ducted inlet, Free outlet. Power rating (kW) does not include transmission losses. Performance ratings do not include the effects of cross winds. Performance ratings do not include the effects of appurtenances (accessories).

The A-weighted sound ratings shown have been calculated per AMCA International Standard 301. Values shown are for outlet LwoA sound power levels for installation Type C: ducted inlet, free outlet.
NB: CHEM HE50 & HDE90 is not licensed to bear the AMCA certified rating seal.



Performance Curve

CHEM HS30 500 CHEM HE30 500



HS 30 Series

CHEM HS30 500

Inlet Airflow

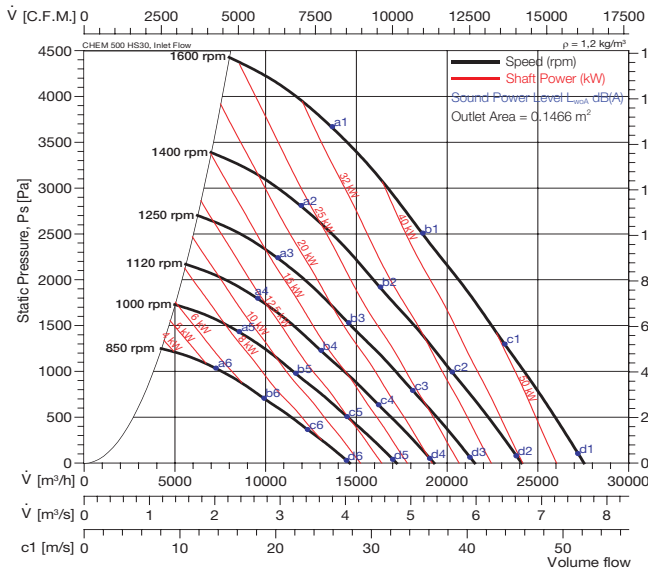

CHEM HS30 500

Outlet Airflow

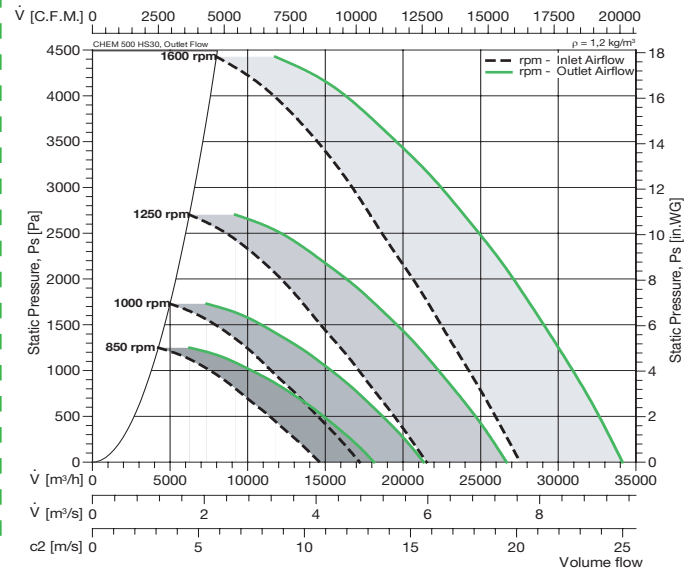

HE 30 Series

CHEM HE30 500

Inlet Airflow

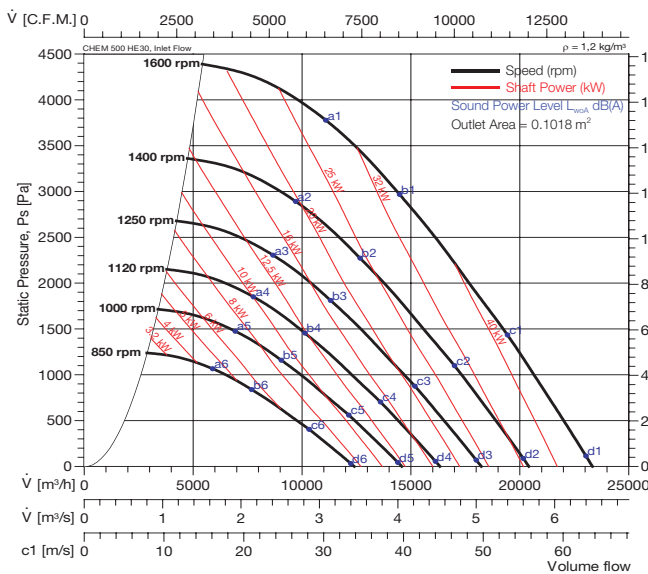

CHEM HE30 500

Outlet Airflow

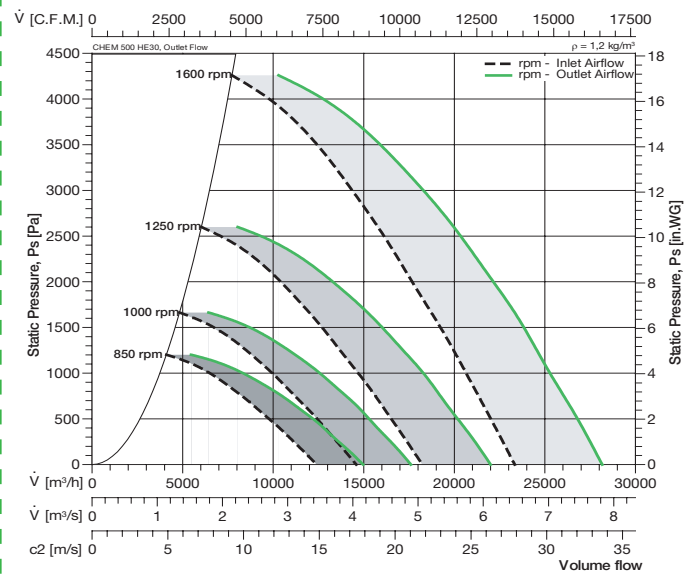

The A-weighted Sound Power Levels

Lwo(A)	a1	b1	c1	d1	a2	b2	c2	d2	a3	b3	c3	d3	a4	b4	c4	d4	a5	b5	c5	d5	a6	b6	c6	d6
HS30	109	111	113	118	105	107	110	115	102	104	106	109	99	101	104	106	97	98	101	103	93	94	97	99
HE30	107	108	110	115	103	104	107	112	100	101	104	106	98	98	101	103	95	95	98	100	91	91	94	96

Fan test laboratory AMCA 210, 260 & 300. Performance certified is for installation type C - Ducted inlet, Free outlet. Power rating (kW) does not include transmission losses. Performance ratings do not include the effects of cross winds. Performance ratings do not include the effects of appurtenances (accessories).

The A-weighted sound ratings shown have been calculated per AMCA International Standard 301. Values shown are for outlet LwoA sound power levels for installation Type C: ducted inlet, free outlet.



HE 50 Series

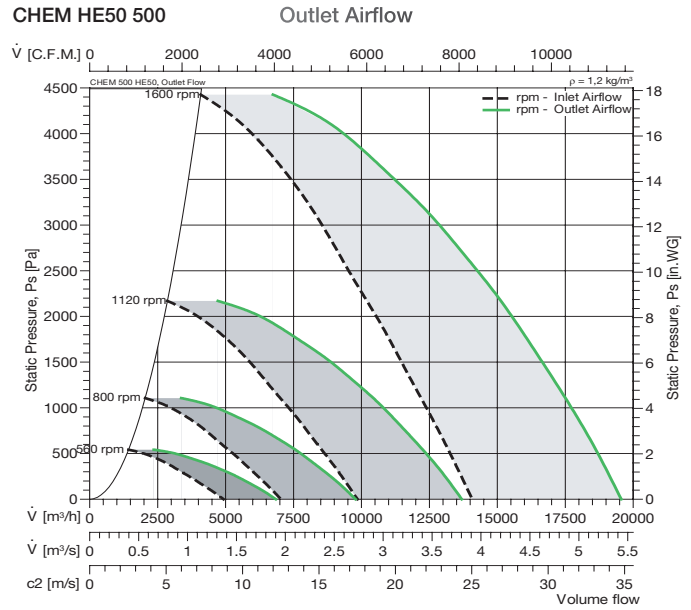
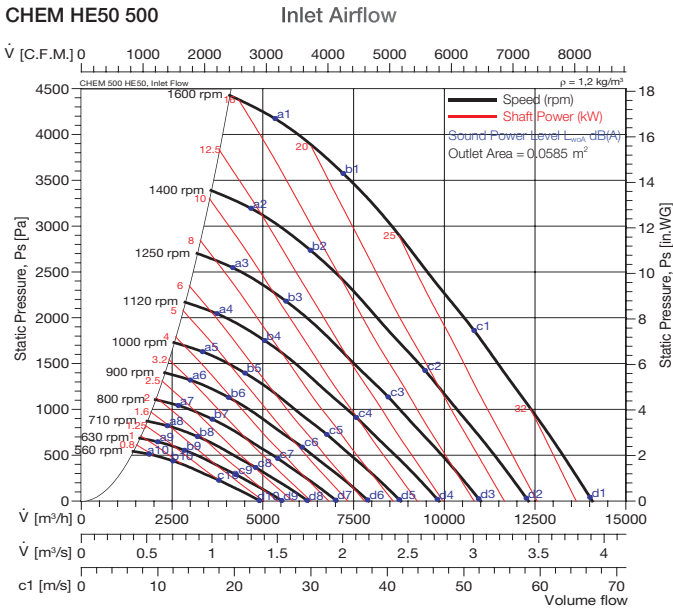

HDE 90 Series

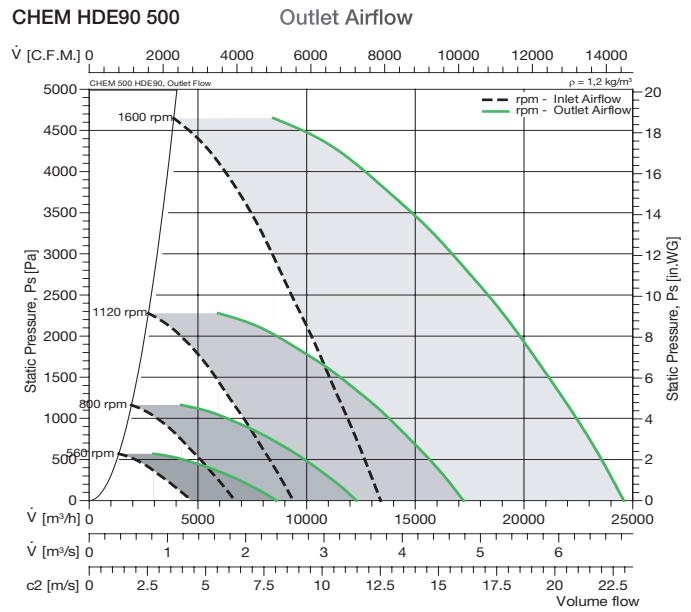
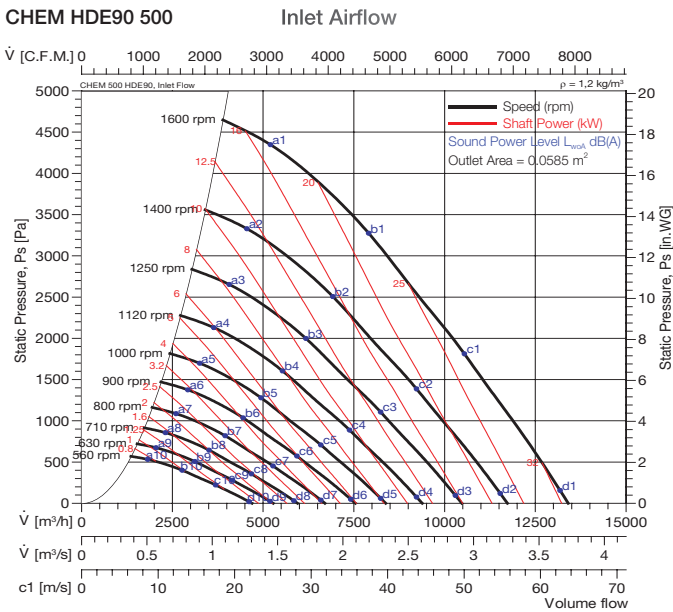

The A-weighted Sound Power Levels

Lwo(A)	a1	b1	c1	d1	a2	b2	c2	d2	a3	b3	c3	d3	a4	b4	c4	d4	a5	b5	c5	d5	a6	b6	c6	d6
HE50	108	107	106	107	104	103	103	104	101	100	100	99	98	98	97	97	95	95	94	94	93	92	91	91
HDE90	108	107	106	107	104	103	103	104	101	100	100	99	98	97	97	97	95	95	94	94	92	92	92	91

Lwo(A)	a7	b7	c7	d7	a8	b8	c8	d8	a9	b9	c9	d9	a10	b10	c10	d10	a11	b11	c11	d11	a12	b12	c12	d12
HE50	90	89	89	89	87	86	86	85	82	82	81	81	79	79	78	78	-	-	-	-	-	-	-	-
HDE90	89	89	89	89	86	86	86	85	82	82	81	81	79	79	78	78	-	-	-	-	-	-	-	-

Fan test laboratory AMCA 210, 260 & 300. Performance s for installation type C - Ducted inlet, Free outlet. Power rating (kW) does not include transmission losses. Performance ratings do not include the effects of cross winds. Performance ratings do not include the effects of appurtenances (accessories).

The A-weighted sound ratings shown have been calculated per AMCA International Standard 301. Values shown are for outlet LwoA sound power levels for installation Type C: ducted inlet, free outlet.
NB: CHEM HE50 & HDE90 is not licensed to bear the AMCA certified rating seal.



Performance Curve

CHEM HS30 560 CHEM HE30 560



HS 30 Series

CHEM HS30 560

Inlet Airflow

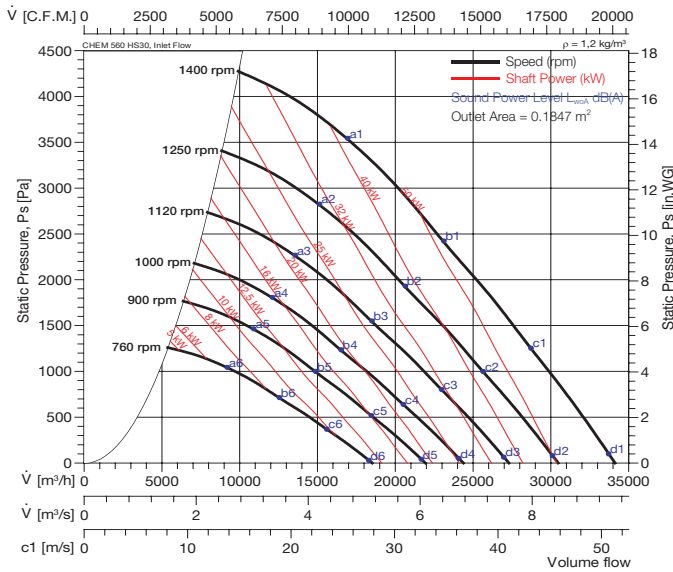

CHEM HS30 560

Outlet Airflow

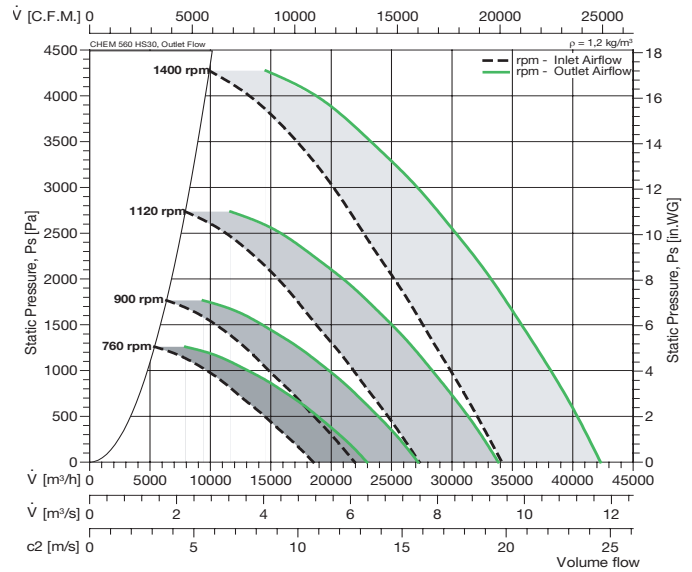

HE 30 Series

CHEM HE30 560

Inlet Airflow

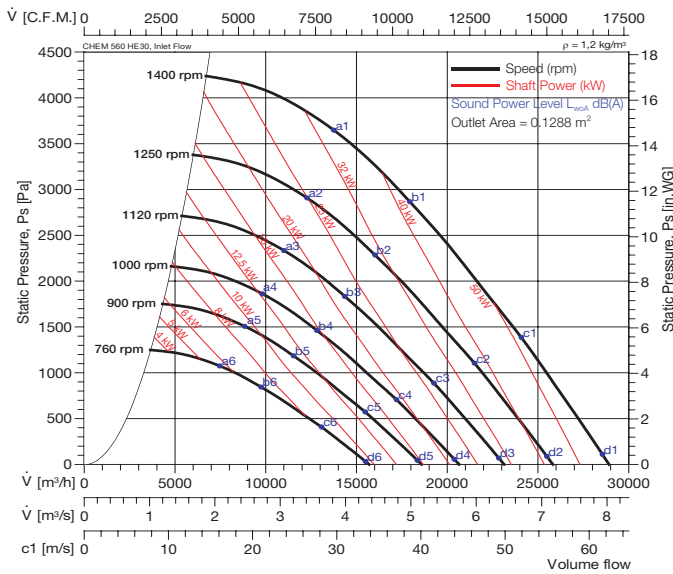

CHEM HE30 560

Outlet Airflow

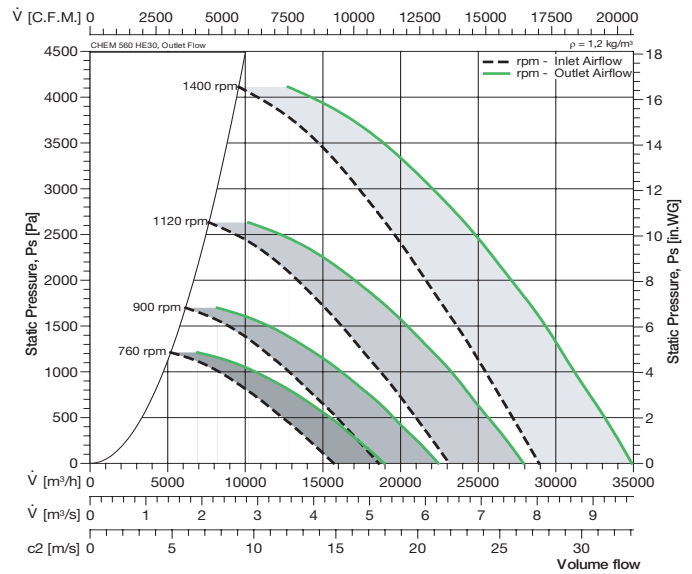

The A-weighted Sound Power Levels

Lwo(A)	a1	b1	c1	d1	a2	b2	c2	d2	a3	b3	c3	d3	a4	b4	c4	d4	a5	b5	c5	d5	a6	b6	c6	d6
HS30	109	111	113	119	106	107	110	112	103	104	107	110	100	102	104	107	97	99	102	104	93	95	98	100
HE30	107	108	110	115	104	105	107	109	101	102	104	106	98	99	101	103	96	96	99	101	91	92	95	97

Fan test laboratory AMCA 210, 260 & 300. Performance certified is for installation type C - Ducted inlet, Free outlet. Power rating (kW) does not include transmission losses. Performance ratings do not include the effects of cross winds. Performance ratings do not include the effects of appurtenances (accessories).

The A-weighted sound ratings shown have been calculated per AMCA International Standard 301. Values shown are for outlet LwoA sound power levels for installation Type C: ducted inlet, free outlet.

HE 50 Series

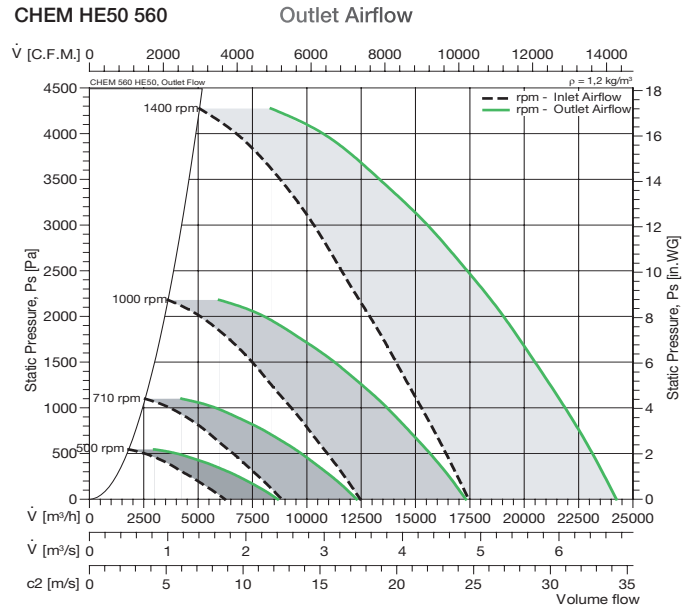
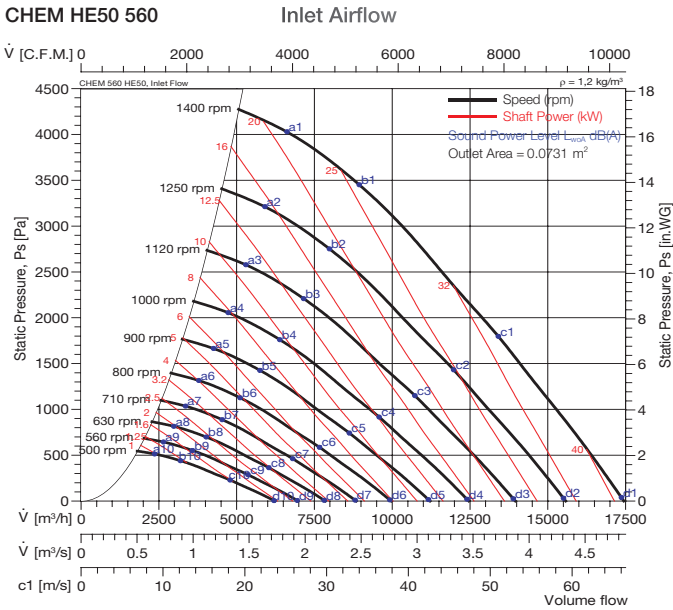

HDE 90 Series

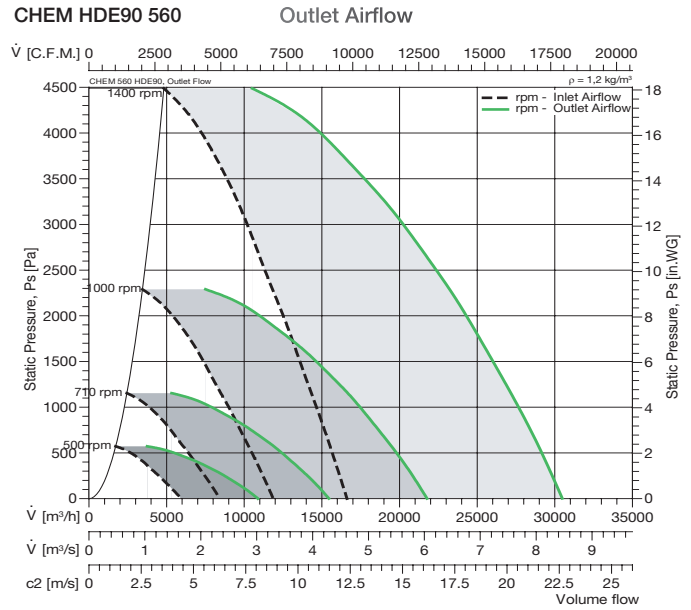
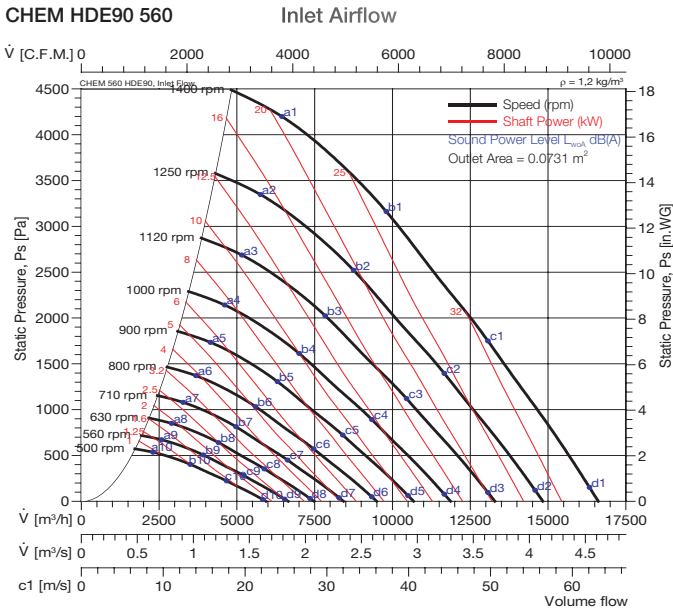

The A-weighted Sound Power Levels

Lwo(A)	a1	b1	c1	d1	a2	b2	c2	d2	a3	b3	c3	d3	a4	b4	c4	d4	a5	b5	c5	d5	a6	b6	c6	d6
HE50	108	107	106	107	105	104	103	103	102	101	100	100	99	98	98	97	96	96	95	95	93	93	92	92
HDE90	107	107	106	107	104	104	103	103	101	101	100	100	99	98	98	97	96	95	95	95	93	93	92	92

Lwo(A)	a7	b7	c7	d7	a8	b8	c8	d8	a9	b9	c9	d9	a10	b10	c10	d10	a11	b11	c11	d11	a12	b12	c12	d12
HE50	90	90	89	89	86	85	85	85	82	82	82	82	79	79	79	79	-	-	-	-	-	-	-	-
HDE90	90	90	89	89	86	85	85	85	82	82	82	82	79	79	79	79	-	-	-	-	-	-	-	-

Fan test laboratory AMCA 210, 260 & 300. Performance s for installation type C - Ducted inlet, Free outlet. Power rating (kW) does not include transmission losses. Performance ratings do not include the effects of cross winds. Performance ratings do not include the effects of appurtenances (accessories).

The A-weighted sound ratings shown have been calculated per AMCA International Standard 301. Values shown are for outlet LwoA sound power levels for installation Type C: ducted inlet, free outlet.
NB: CHEM HE50 & HDE90 is not licensed to bear the AMCA certified rating seal.



Performance Curve

CHEM HS30 630 CHEM HE30 630



HS 30 Series

CHEM HS30 630

Inlet Airflow

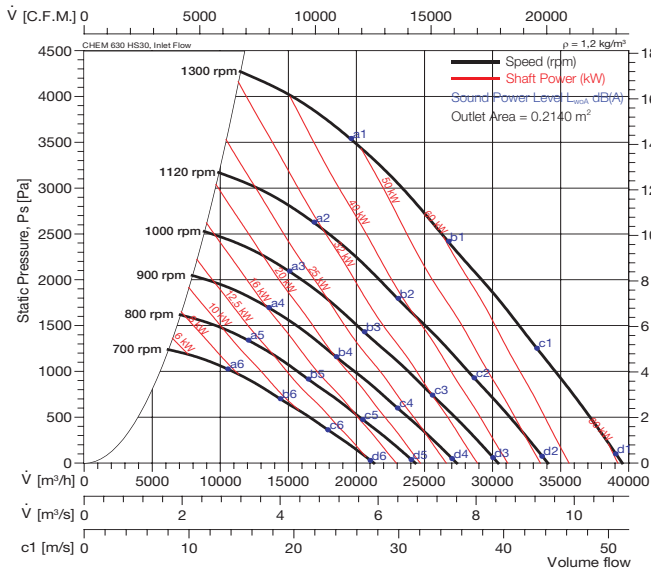

CHEM HS30 630

Outlet Airflow

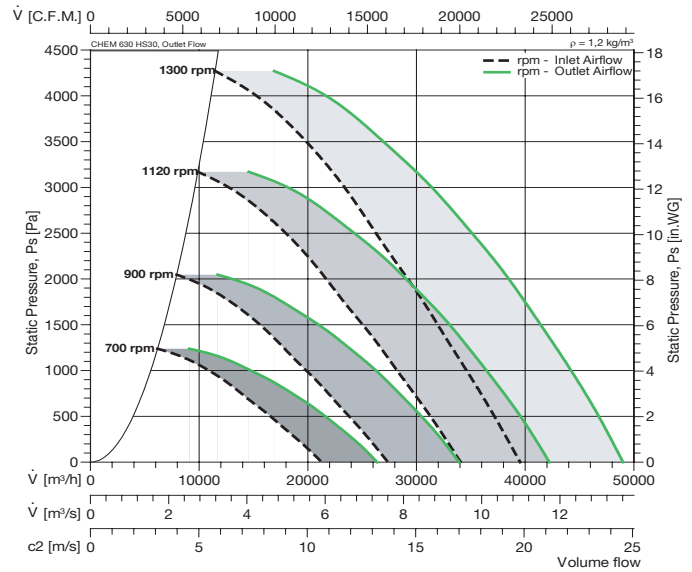

HE 30 Series

CHEM HE30 630

Inlet Airflow

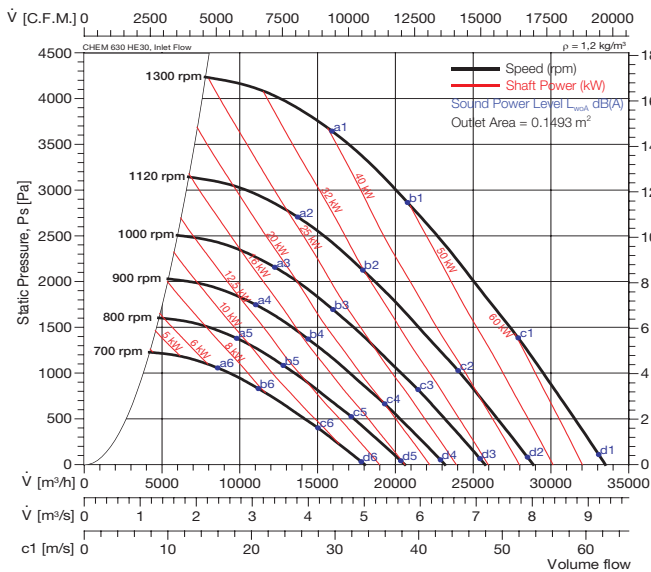

CHEM HE30 630

Outlet Airflow

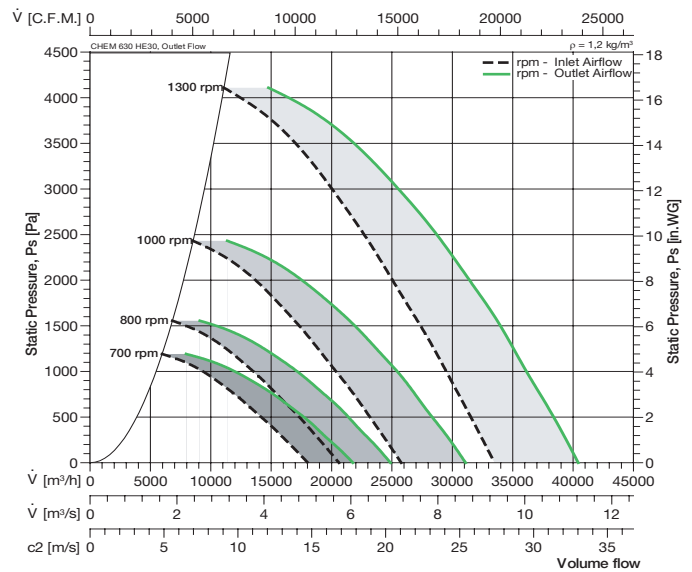

The A-weighted Sound Power Levels

Lwo(A)	a1	b1	c1	d1	a2	b2	c2	d2	a3	b3	c3	d3	a4	b4	c4	d4	a5	b5	c5	d5	a6	b6	c6	d6
HS30	109	111	113	116	105	107	109	112	102	103	106	109	100	102	104	107	97	99	101	104	94	96	98	101
HE30	107	108	110	113	103	104	106	109	100	101	103	106	98	98	101	103	95	95	98	100	92	92	95	97

Fan test laboratory AMCA 210, 260 & 300. Performance certified is for installation type C - Ducted inlet, Free outlet. Power rating (kW) does not include transmission losses. Performance ratings do not include the effects of cross winds. Performance ratings do not include the effects of appurtenances (accessories).

The A-weighted sound ratings shown have been calculated per AMCA International Standard 301. Values shown are for outlet LwoA sound power levels for installation Type C: ducted inlet, free outlet.



HE 50 Series

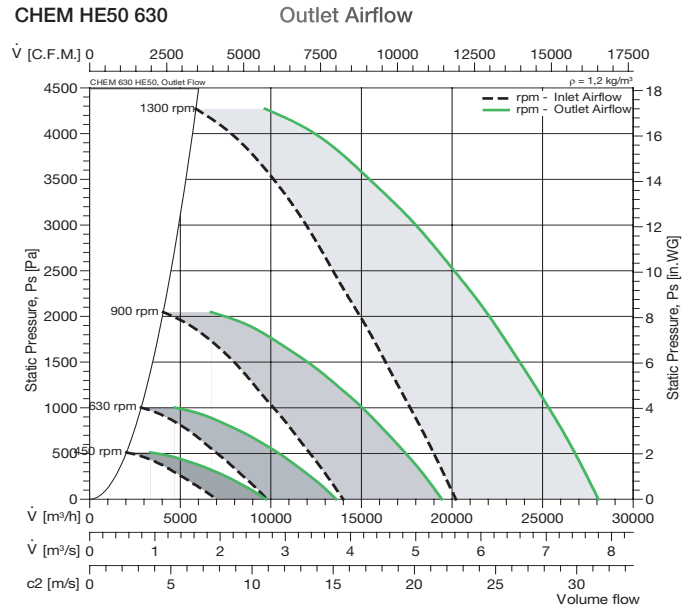
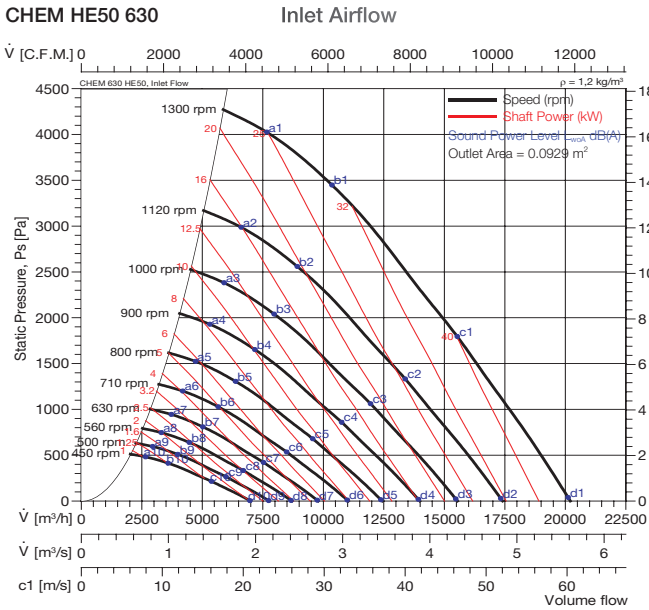

HDE 90 Series

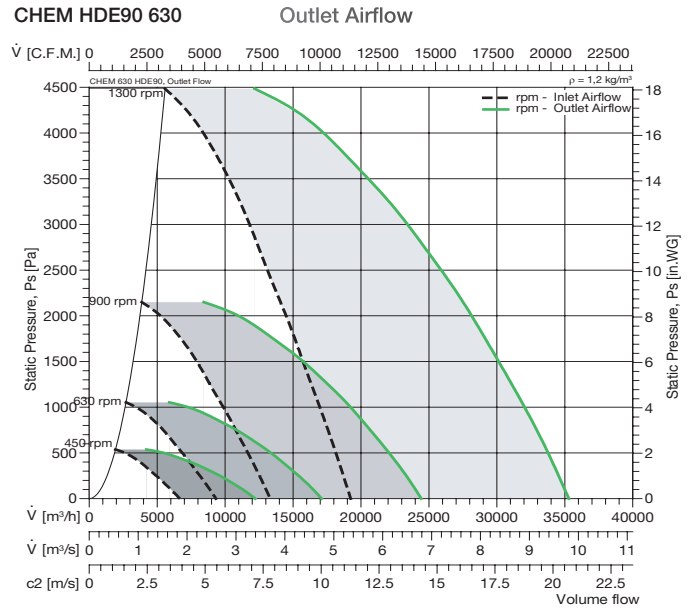
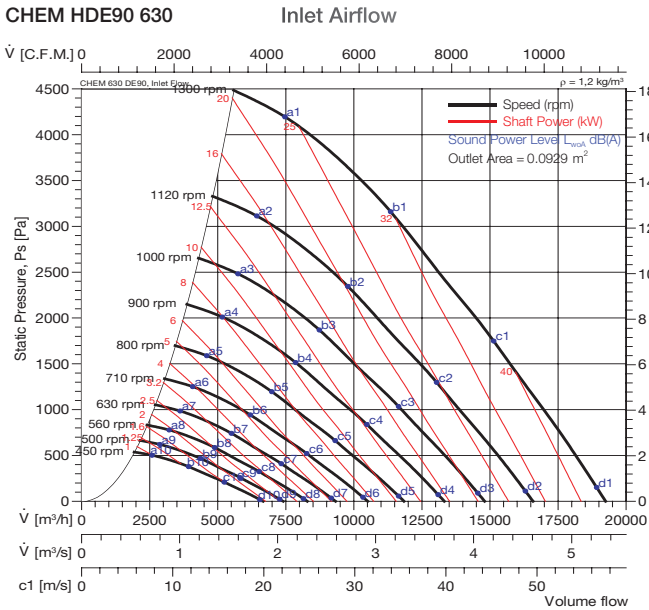

The A-weighted Sound Power Levels

Lwo(A)	a1	b1	c1	d1	a2	b2	c2	d2	a3	b3	c3	d3	a4	b4	c4	d4	a5	b5	c5	d5	a6	b6	c6	d6
HE50	108	107	106	106	104	103	103	102	101	100	100	100	98	98	97	97	95	95	94	94	92	92	91	91
HDE90	108	107	107	106	104	103	103	102	101	100	100	99	98	98	97	97	95	95	94	94	92	92	91	91

Lwo(A)	a7	b7	c7	d7	a8	b8	c8	d8	a9	b9	c9	d9	a10	b10	c10	d10	a11	b11	c11	d11	a12	b12	c12	d12
HE50	88	88	87	87	85	84	84	84	82	81	81	81	79	78	78	78	-	-	-	-	-	-	-	-
HDE90	88	87	87	87	85	84	84	84	81	81	81	81	79	78	78	78	-	-	-	-	-	-	-	-

Fan test laboratory AMCA 210, 260 & 300. Performance s for installation type C - Ducted inlet, Free outlet. Power rating (kW) does not include transmission losses. Performance ratings do not include the effects of cross winds. Performance ratings do not include the effects of appurtenances (accessories).

The A-weighted sound ratings shown have been calculated per AMCA International Standard 301. Values shown are for outlet LwoA sound power levels for installation Type C: ducted inlet, free outlet.
NB: CHEM HE50 & HDE90 is not licensed to bear the AMCA certified rating seal.



Performance Curve

CHEM HS30 710 CHEM HE30 710



HS 30 Series

CHEM HS30 710

Inlet Airflow

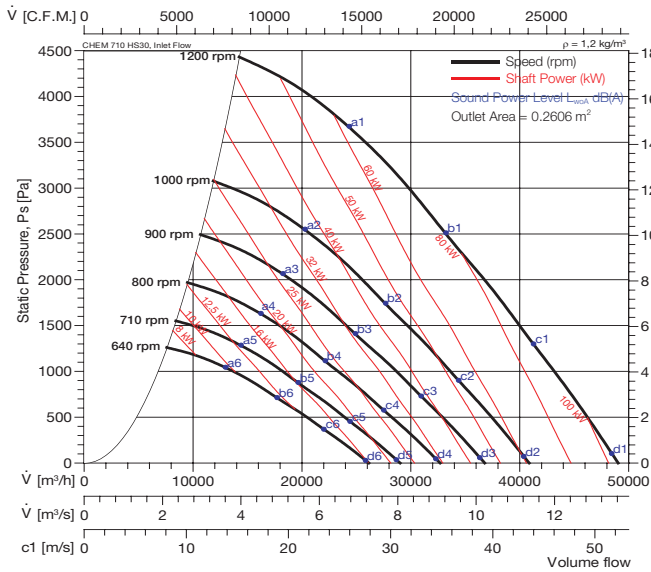

CHEM HS30 710

Outlet Airflow

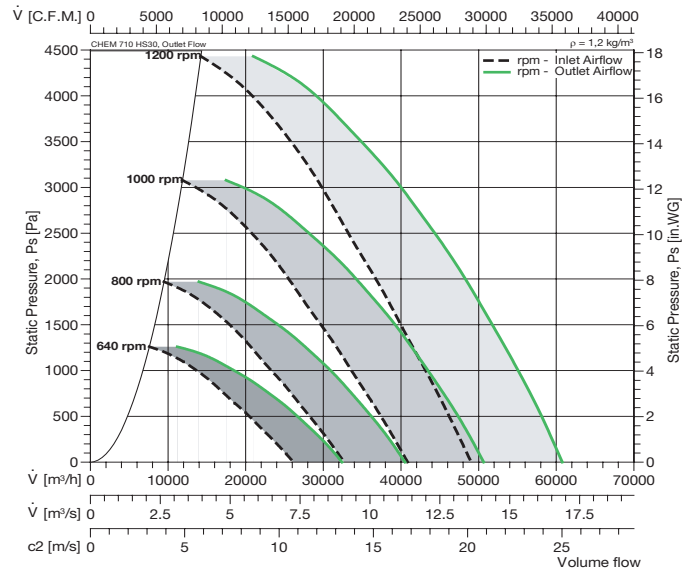

HE 30 Series

CHEM HE30 710

Inlet Airflow

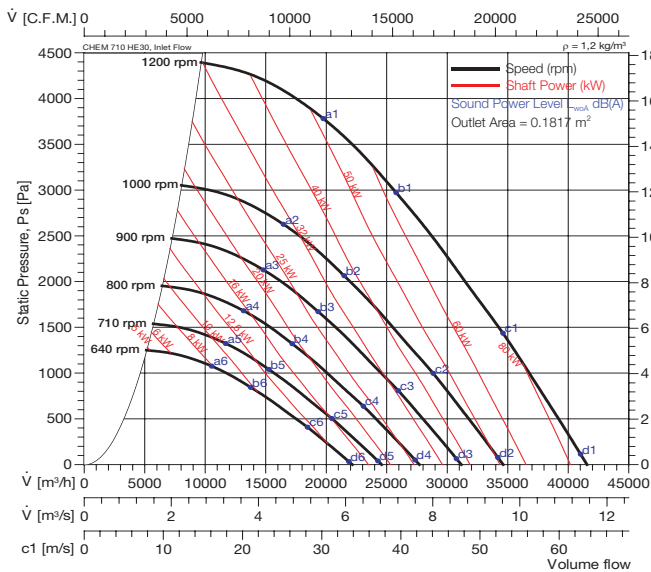

CHEM HE30 710

Outlet Airflow

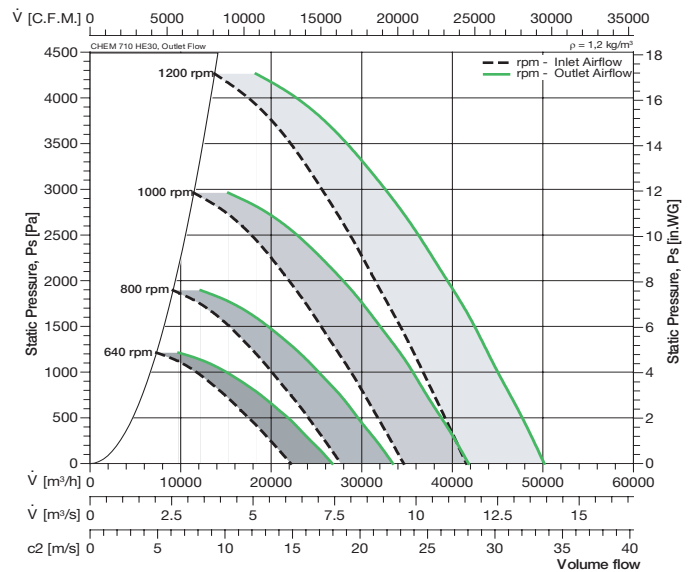

The A-weighted Sound Power Levels

Lwo(A)	a1	b1	c1	d1	a2	b2	c2	d2	a3	b3	c3	d3	a4	b4	c4	d4	a5	b5	c5	d5	a6	b6	c6	d6
HS30	110	112	114	117	105	106	109	112	102	103	106	110	100	102	104	107	97	99	102	104	92	94	96	98
HE30	108	109	111	113	103	104	106	109	100	101	103	106	98	98	101	103	95	95	98	101	91	91	93	95

Fan test laboratory AMCA 210, 260 & 300. Performance certified is for installation type C - Ducted inlet, Free outlet. Power rating (kW) does not include transmission losses. Performance ratings do not include the effects of cross winds. Performance ratings do not include the effects of appurtenances (accessories).

The A-weighted sound ratings shown have been calculated per AMCA International Standard 301. Values shown are for outlet LwoA sound power levels for installation Type C: ducted inlet, free outlet.

HE 50 Series

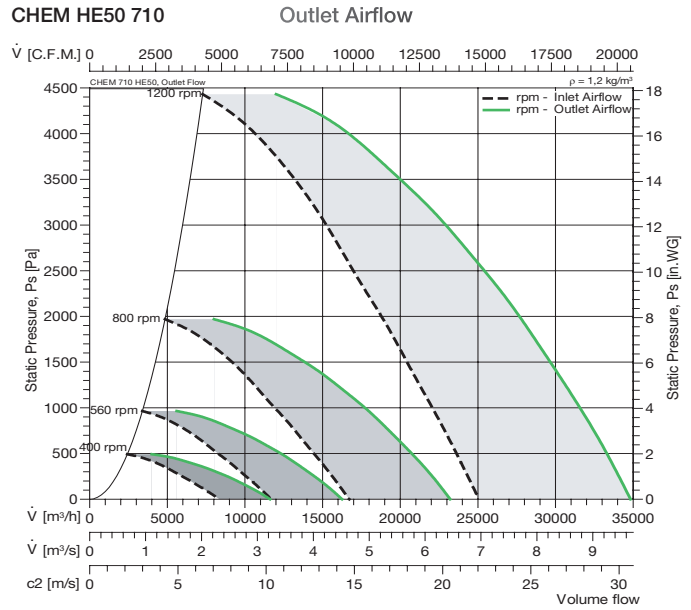
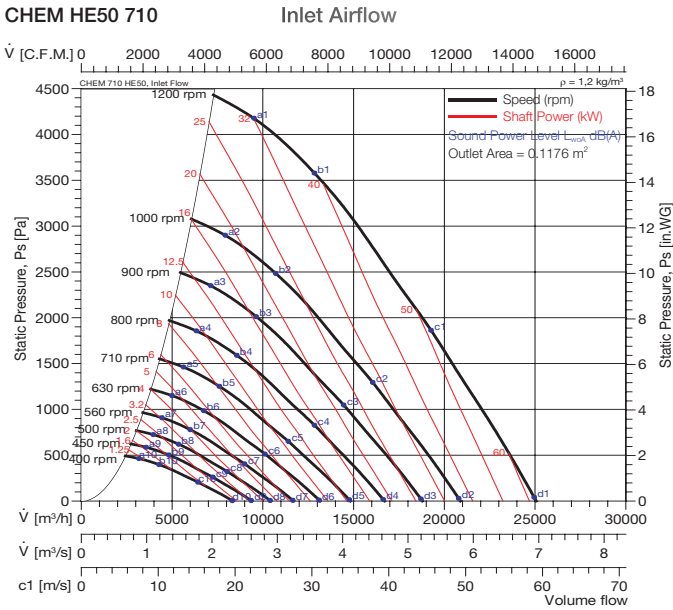

HDE 90 Series

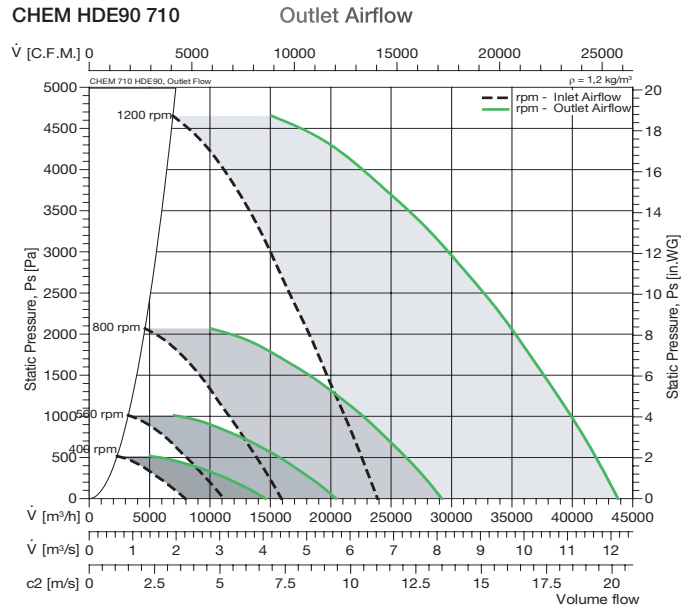
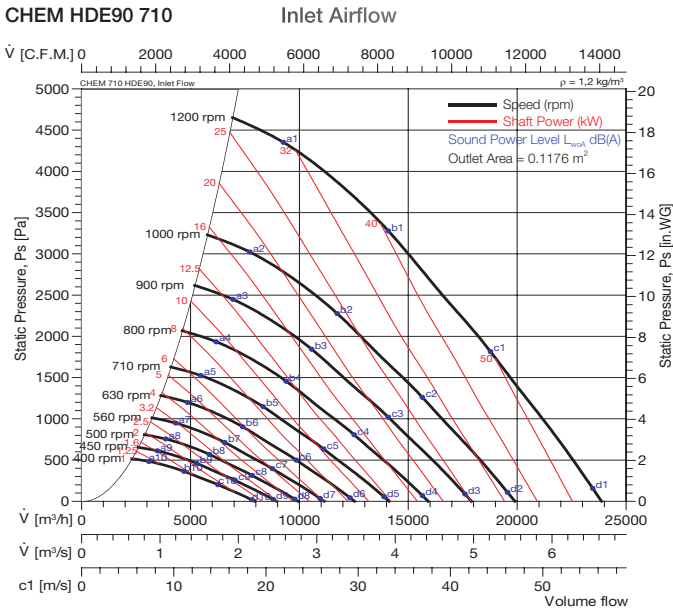

The A-weighted Sound Power Levels

Lwo(A)	a1	b1	c1	d1	a2	b2	c2	d2	a3	b3	c3	d3	a4	b4	c4	d4	a5	b5	c5	d5	a6	b6	c6	d6
HE50	109	108	107	107	104	103	103	103	101	100	100	100	98	98	97	97	95	95	94	94	91	91	90	90
HDE90	109	108	107	107	104	103	103	102	101	100	100	100	98	98	97	97	95	95	94	94	91	90	90	90

Lwo(A)	a7	b7	c7	d7	a8	b8	c8	d8	a9	b9	c9	d9	a10	b10	c10	d10	a11	b11	c11	d11	a12	b12	c12	d12
HE50	88	87	87	87	85	84	84	85	82	81	81	81	79	78	78	78	-	-	-	-	-	-	-	-
HDE90	88	87	87	87	84	84	84	85	82	81	81	81	78	78	78	78	-	-	-	-	-	-	-	-

Fan test laboratory AMCA 210, 260 & 300. Performance s for installation type C - Ducted inlet, Free outlet. Power rating (kW) does not include transmission losses. Performance ratings do not include the effects of cross winds. Performance ratings do not include the effects of appurtenances (accessories).

The A-weighted sound ratings shown have been calculated per AMCA International Standard 301. Values shown are for outlet LwoA sound power levels for installation Type C: ducted inlet, free outlet.
NB: CHEM HE50 & HDE90 is not licensed to bear the AMCA certified rating seal.



Performance Curve

CHEM HS30 800 CHEM HE30 800



HS 30 Series

CHEM HS30 800

Inlet Airflow

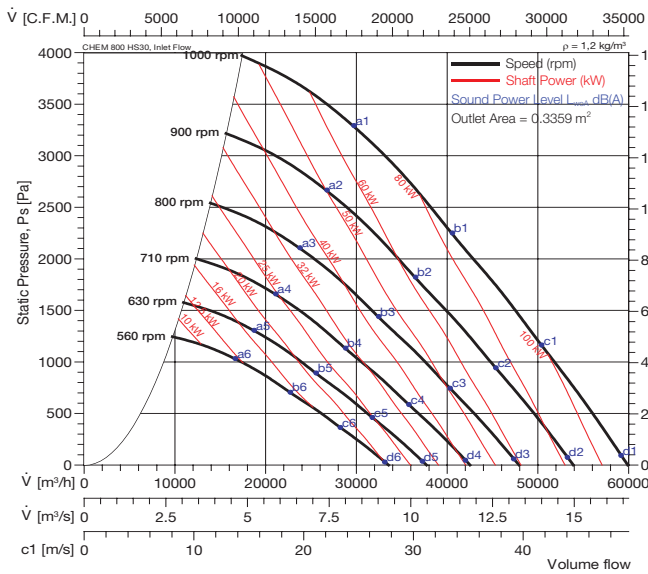

CHEM HS30 800

Outlet Airflow

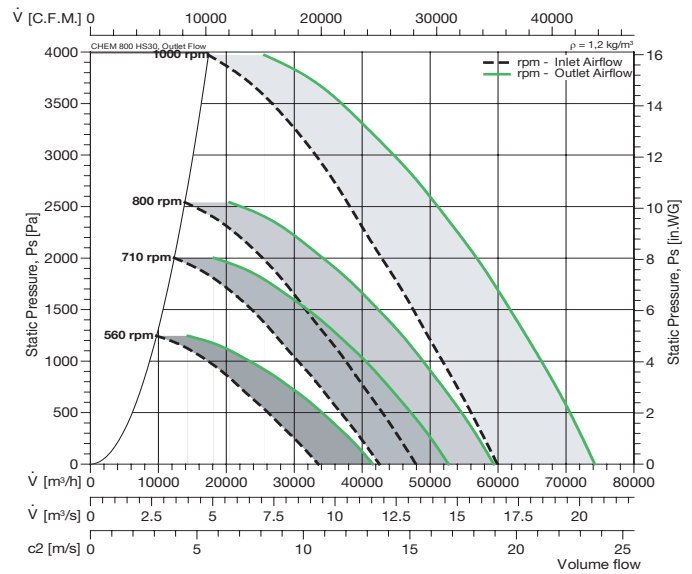

HE 30 Series

CHEM HE30 800

Inlet Airflow

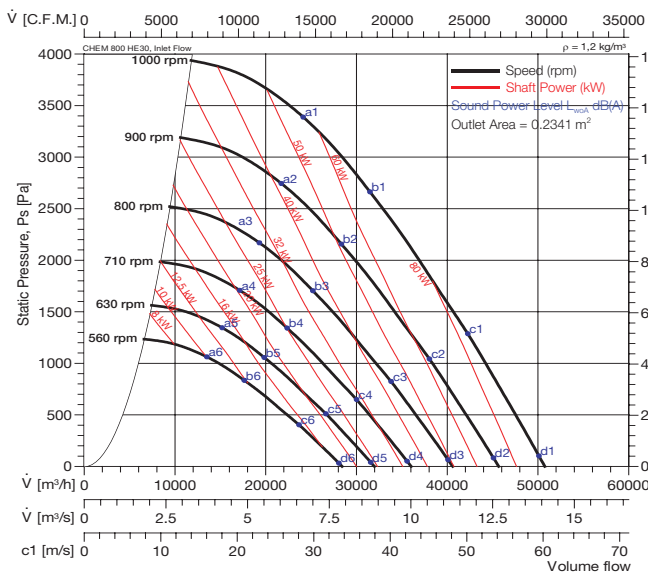

CHEM HE30 800

Outlet Airflow

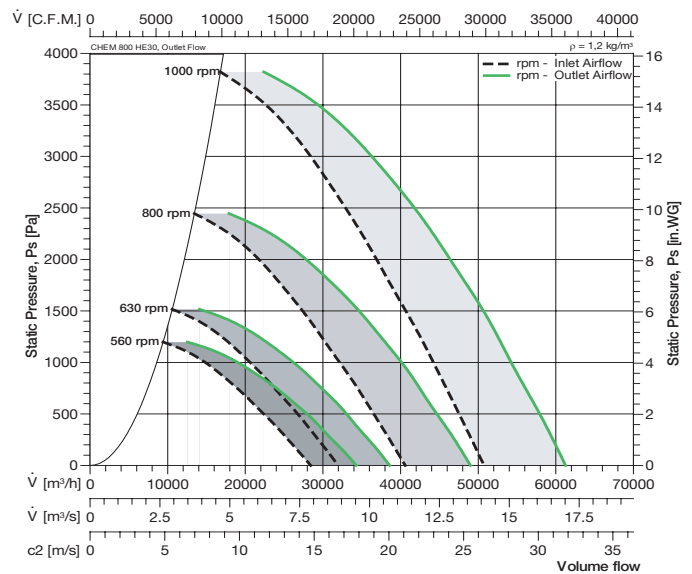

The A-weighted Sound Power Levels

	Lwo(A)	a1	b1	c1	d1	a2	b2	c2	d2	a3	b3	c3	d3	a4	b4	c4	d4	a5	b5	c5	d5	a6	b6	c6	d6
HS30	109	110	113	116	106	107	110	113	102	104	106	111	101	103	105	108	96	97	99	102	93	94	96	99	
HE30	107	108	110	113	104	105	107	110	101	101	103	107	99	99	102	105	94	95	96	98	91	92	93	95	

Fan test laboratory AMCA 210, 260 & 300. Performance certified is for installation type C - Ducted inlet, Free outlet. Power rating (kW) does not include transmission losses. Performance ratings do not include the effects of cross winds. Performance ratings do not include the effects of appurtenances (accessories).

The A-weighted sound ratings shown have been calculated per AMCA International Standard 301. Values shown are for outlet LwoA sound power levels for installation Type C: ducted inlet, free outlet.



HE 50 Series

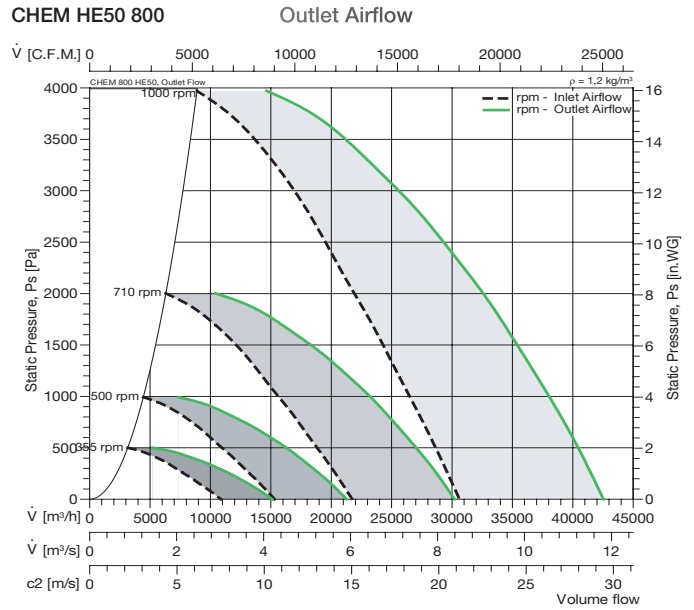
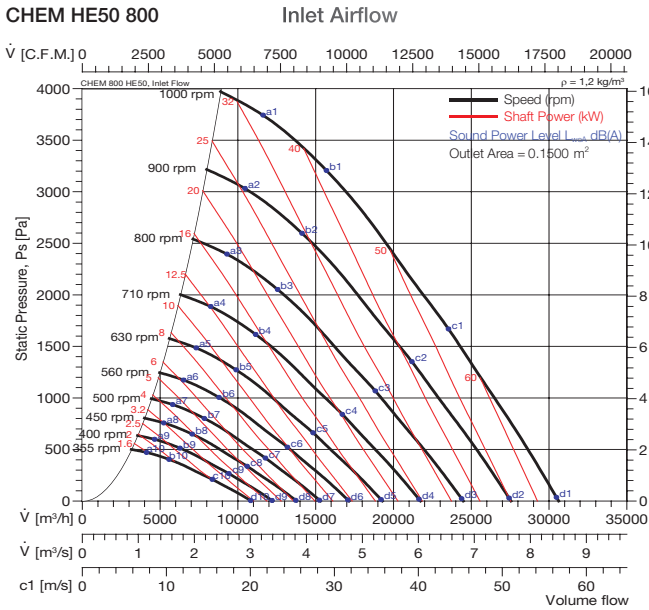

HDE 90 Series

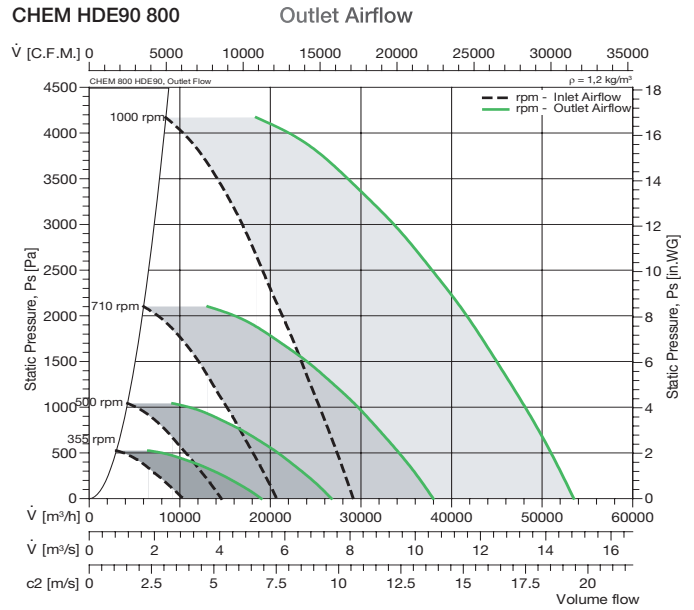
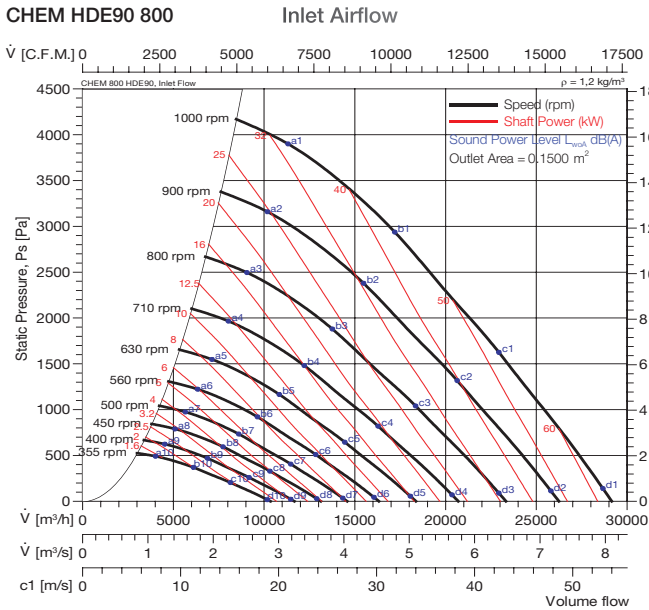

The A-weighted Sound Power Levels

Lwo(A)	a1	b1	c1	d1	a2	b2	c2	d2	a3	b3	c3	d3	a4	b4	c4	d4	a5	b5	c5	d5	a6	b6	c6	d6
HE50	108	107	106	106	105	104	104	104	101	101	100	101	99	99	98	98	95	94	94	94	91	91	91	91
HDE90	107	107	107	106	105	104	104	104	101	101	101	101	99	99	98	98	95	94	94	94	91	91	91	91

Lwo(A)	a7	b7	c7	d7	a8	b8	c8	d8	a9	b9	c9	d9	a10	b10	c10	d10	a11	b11	c11	d11	a12	b12	c12	d12
HE50	88	88	88	88	86	85	85	85	82	82	82	82	79	79	79	79	-	-	-	-	-	-	-	-
HDE90	88	88	88	88	86	85	85	85	82	82	82	82	79	79	79	79	-	-	-	-	-	-	-	-

Fan test laboratory AMCA 210, 260 & 300. Performance s for installation type C - Ducted inlet, Free outlet. Power rating (kW) does not include transmission losses. Performance ratings do not include the effects of cross winds. Performance ratings do not include the effects of appurtenances (accessories).

The A-weighted sound ratings shown have been calculated per AMCA International Standard 301. Values shown are for outlet LwoA sound power levels for installation Type C: ducted inlet, free outlet.
 NB: CHEM HE50 & HDE90 is not licensed to bear the AMCA certified rating seal.



Performance Curve

CHEM HS30 900 CHEM HE30 900



HS 30 Series

CHEM HS30 900

Inlet Airflow

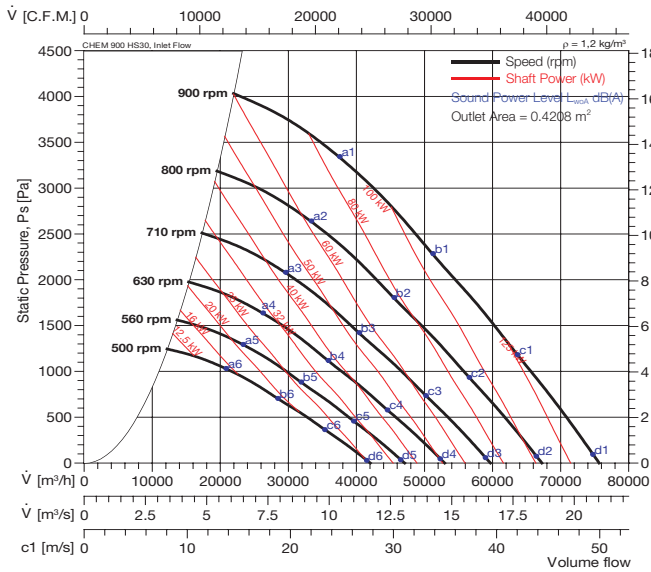

CHEM HS30 900

Outlet Airflow

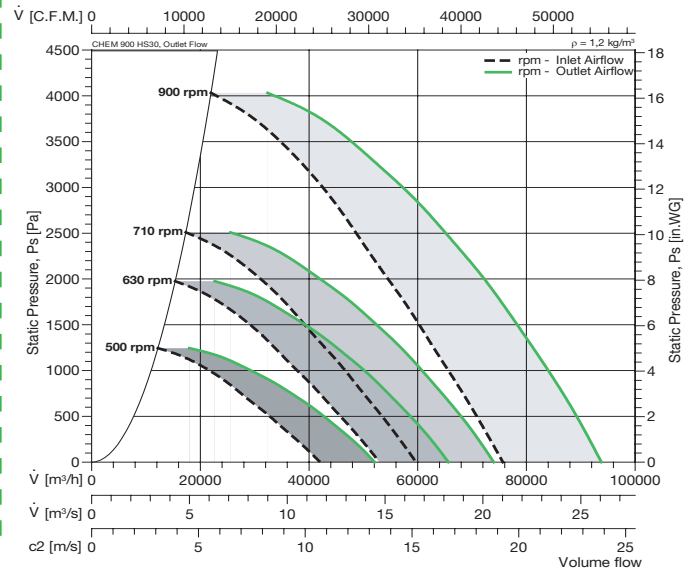

HE 30 Series

CHEM HE30 900

Inlet Airflow

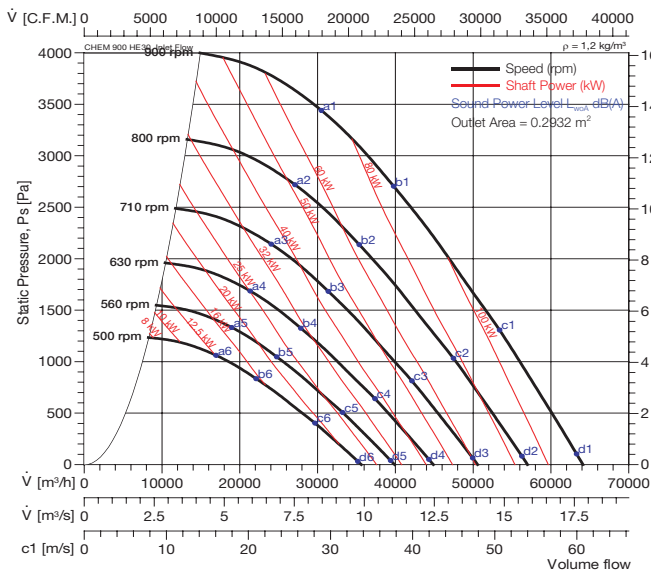

CHEM HE30 900

Outlet Airflow

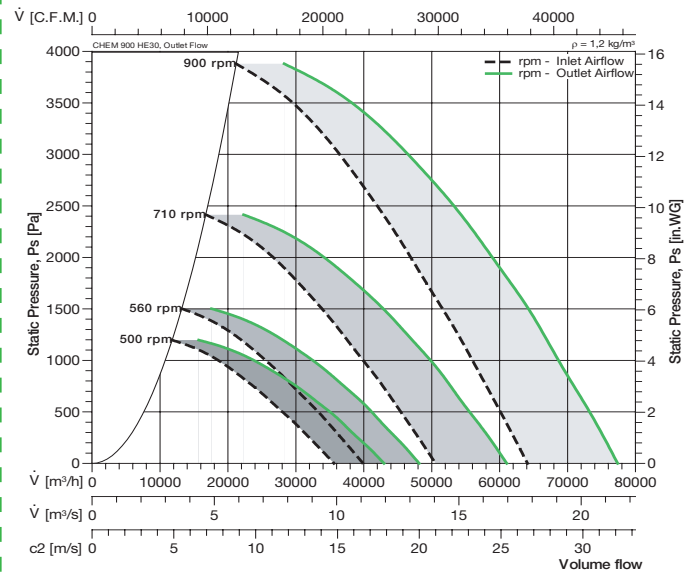

The A-weighted Sound Power Levels

Lwo(A)	a1	b1	c1	d1	a2	b2	c2	d2	a3	b3	c3	d3	a4	b4	c4	d4	a5	b5	c5	d5	a6	b6	c6	d6
HS30	109	111	113	117	106	107	110	114	103	104	106	111	99	100	103	105	96	97	99	102	93	94	96	99
HE30	108	108	110	113	104	105	107	111	101	102	103	108	98	98	100	102	95	95	97	99	92	92	93	95

Fan test laboratory AMCA 210, 260 & 300. Performance certified is for installation type C - Ducted inlet, Free outlet. Power rating (kW) does not include transmission losses. Performance ratings do not include the effects of cross winds. Performance ratings do not include the effects of appurtenances (accessories).

The A-weighted sound ratings shown have been calculated per AMCA International Standard 301. Values shown are for outlet LwoA sound power levels for installation Type C: ducted inlet, free outlet.



HE 50 Series

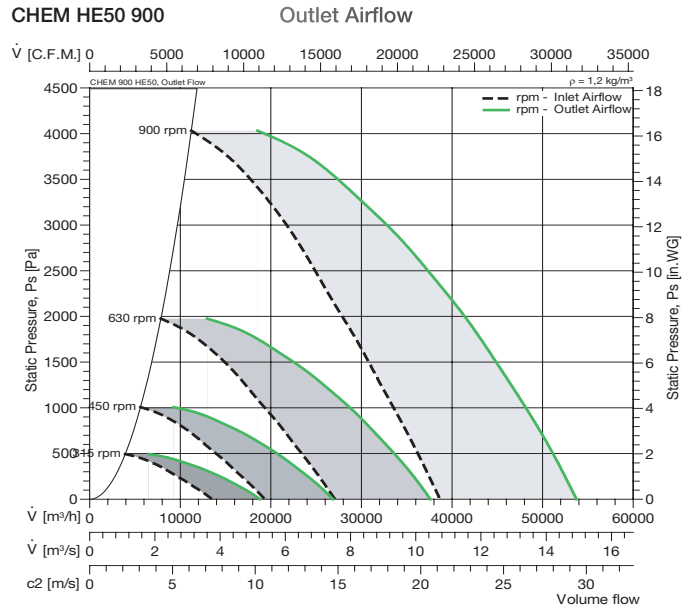
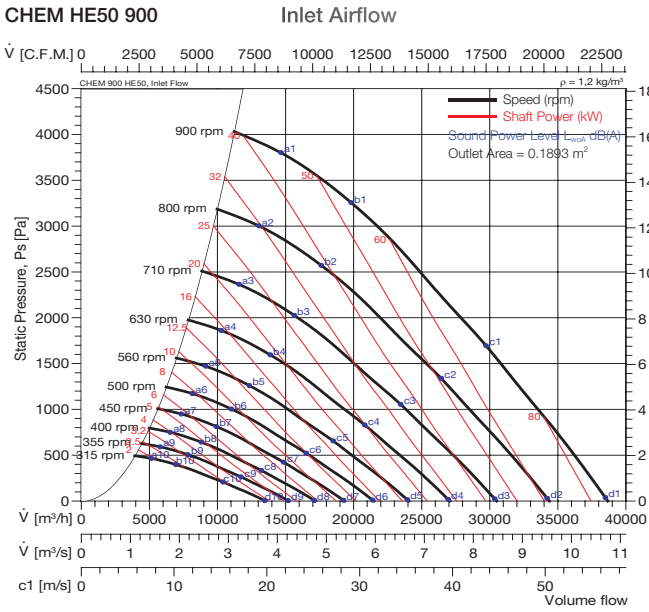

HDE 90 Series

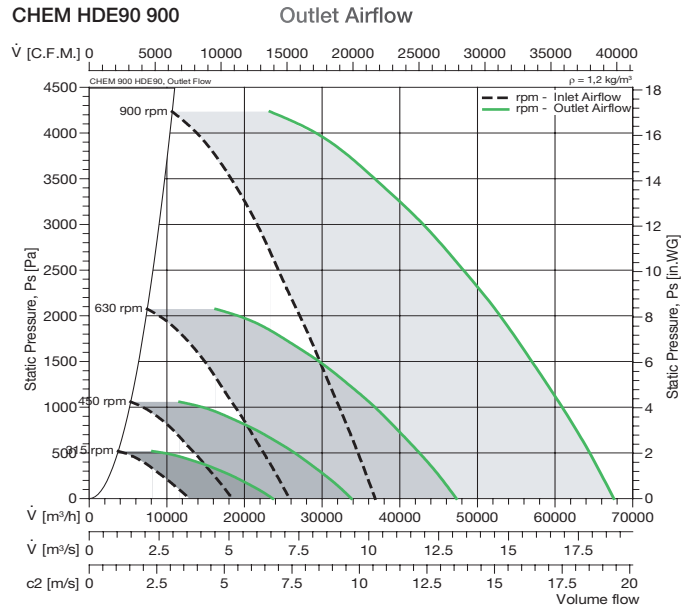
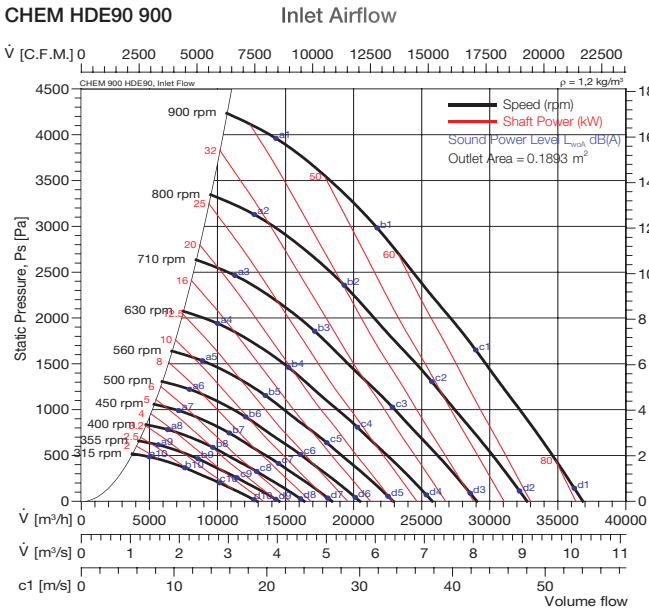

The A-weighted Sound Power Levels

Lwo(A)	a1	b1	c1	d1	a2	b2	c2	d2	a3	b3	c3	d3	a4	b4	c4	d4	a5	b5	c5	d5	a6	b6	c6	d6
HE50	108	108	107	107	105	104	104	104	102	101	101	101	98	98	98	97	95	95	94	94	92	92	91	91
HDE90	108	108	107	107	105	104	104	104	101	101	101	101	98	98	98	97	95	95	94	94	92	92	91	91

Lwo(A)	a7	b7	c7	d7	a8	b8	c8	d8	a9	b9	c9	d9	a10	b10	c10	d10	a11	b11	c11	d11	a12	b12	c12	d12
HE50	89	89	89	89	86	86	86	85	83	82	82	82	79	79	79	79	-	-	-	-	-	-	-	-
HDE90	89	89	89	89	86	86	86	85	83	82	82	82	79	79	79	79	-	-	-	-	-	-	-	-

Fan test laboratory AMCA 210, 260 & 300. Performance s for installation type C - Ducted inlet, Free outlet. Power rating (kW) does not include transmission losses. Performance ratings do not include the effects of cross winds. Performance ratings do not include the effects of appurtenances (accessories).

The A-weighted sound ratings shown have been calculated per AMCA International Standard 301. Values shown are for outlet LwoA sound power levels for installation Type C: ducted inlet, free outlet.
 NB: CHEM HE50 & HDE90 is not licensed to bear the AMCA certified rating seal.



Performance Curve

CHEM HS30 1000 CHEM HE30 1000



HS 30 Series

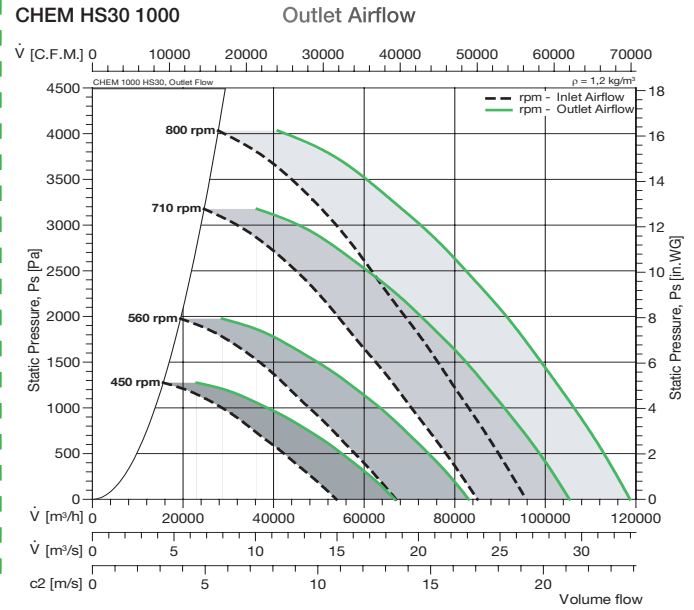
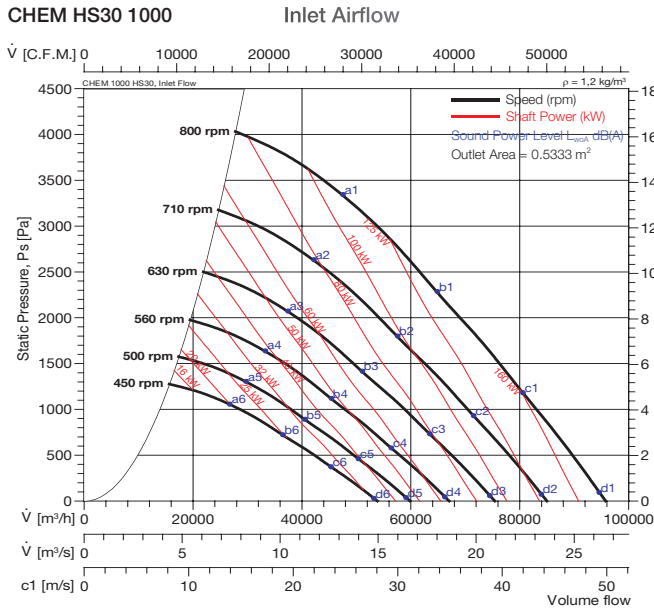

HE 30 Series

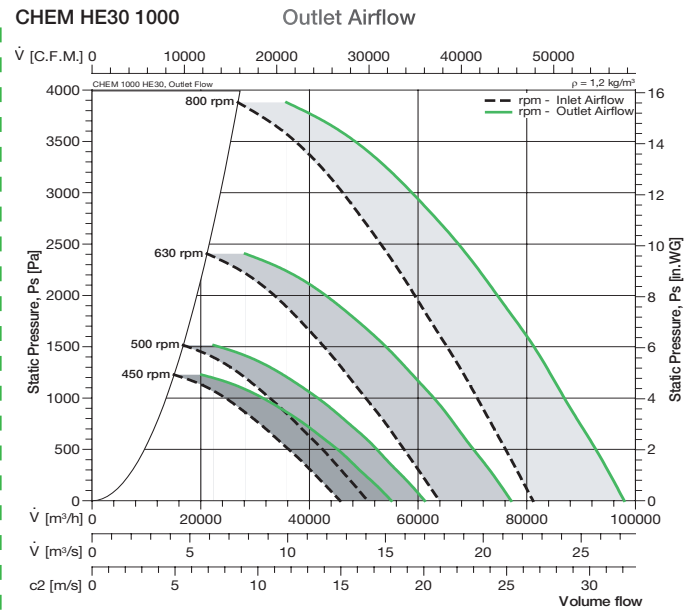
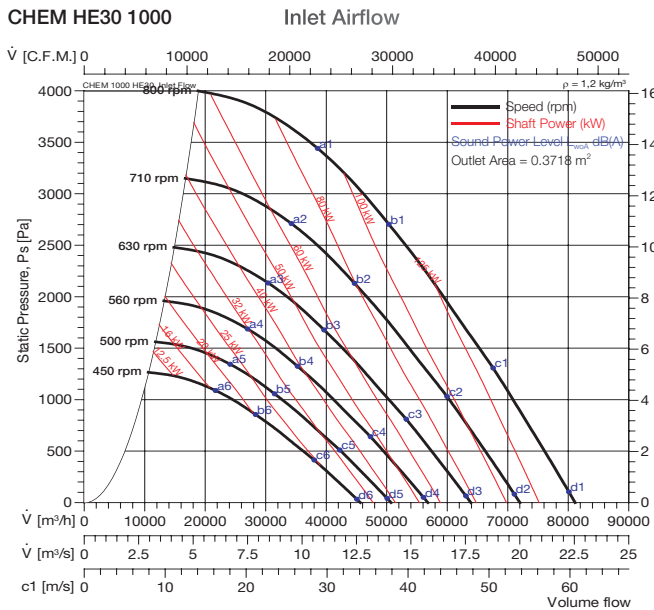

The A-weighted Sound Power Levels

Lwo(A)	a1	b1	c1	d1	a2	b2	c2	d2	a3	b3	c3	d3	a4	b4	c4	d4	a5	b5	c5	d5	a6	b6	c6	d6
HS30	109	111	113	118	106	107	110	115	103	104	106	109	100	101	103	106	97	98	100	103	94	95	97	100
HE30	108	108	110	114	105	105	107	112	101	102	103	105	98	99	100	102	95	95	97	99	92	93	94	96

Fan test laboratory AMCA 210, 260 & 300. Performance certified is for installation type C - Ducted inlet, Free outlet. Power rating (kW) does not include transmission losses. Performance ratings do not include the effects of cross winds. Performance ratings do not include the effects of appurtenances (accessories).

The A-weighted sound ratings shown have been calculated per AMCA International Standard 301. Values shown are for outlet LwoA sound power levels for installation Type C: ducted inlet, free outlet.

HE 50 Series

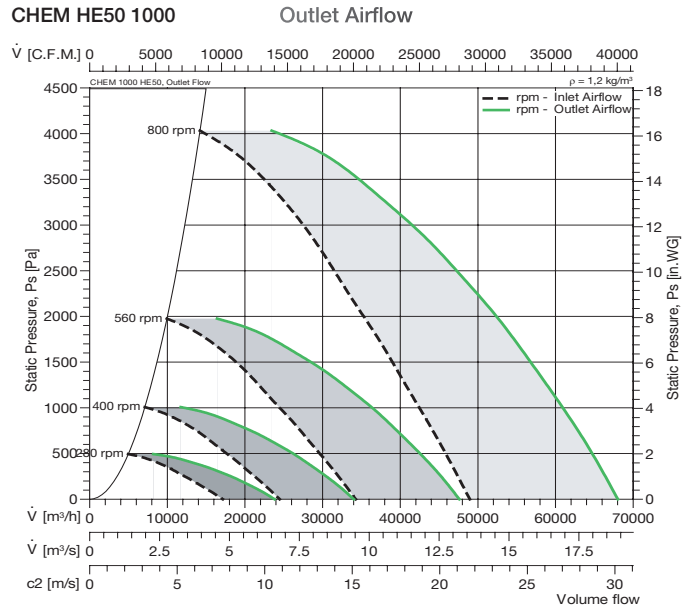
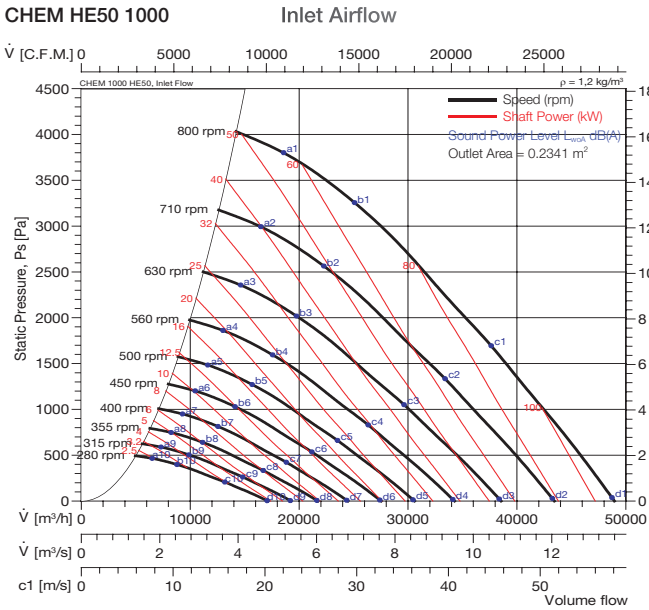

HDE 90 Series

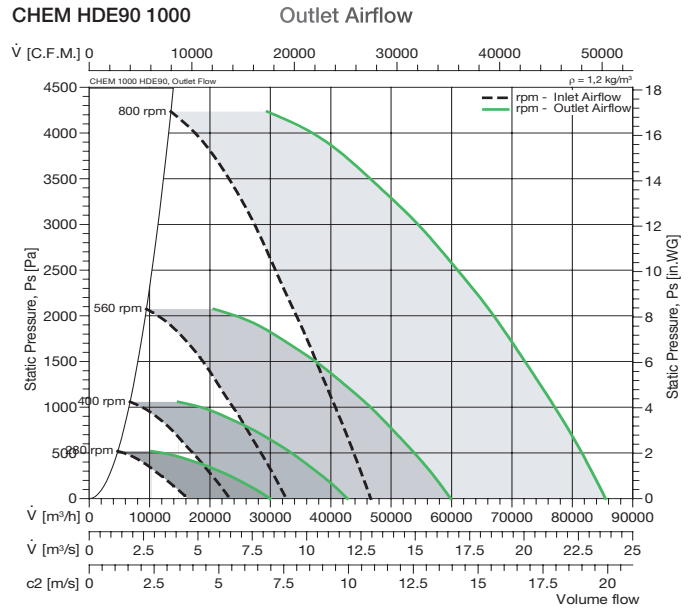
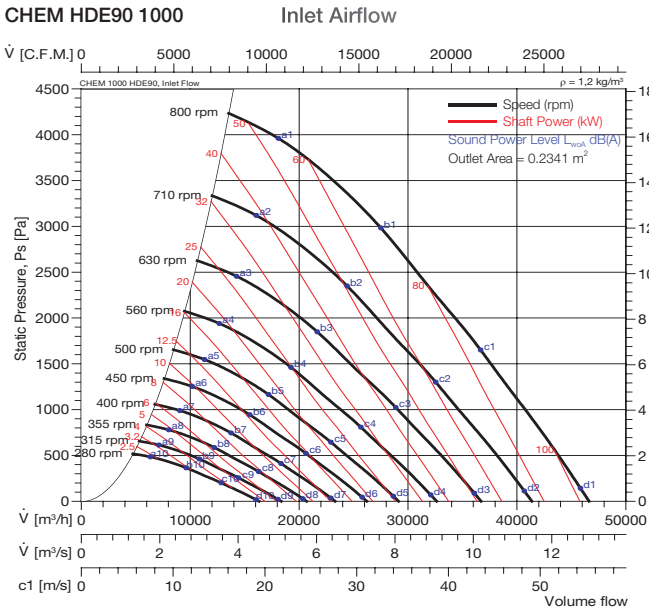

The A-weighted Sound Power Levels

Lwo(A)	a1	b1	c1	d1	a2	b2	c2	d2	a3	b3	c3	d3	a4	b4	c4	d4	a5	b5	c5	d5	a6	b6	c6	d6
HE50	108	108	107	108	105	105	104	105	102	101	101	101	99	98	98	98	95	95	95	95	93	92	92	92
HDE90	108	108	108	108	105	105	104	105	102	101	101	101	98	98	98	98	95	95	95	95	93	92	92	92

Lwo(A)	a7	b7	c7	d7	a8	b8	c8	d8	a9	b9	c9	d9	a10	b10	c10	d10	a11	b11	c11	d11	a12	b12	c12	d12
HE50	89	89	89	89	86	86	86	86	82	82	82	82	79	79	79	79	-	-	-	-	-	-	-	-
HDE90	89	89	89	89	86	86	86	86	82	82	82	82	79	79	79	79	-	-	-	-	-	-	-	-

Fan test laboratory AMCA 210, 260 & 300. Performance s for installation type C - Ducted inlet, Free outlet. Power rating (kW) does not include transmission losses. Performance ratings do not include the effects of cross winds. Performance ratings do not include the effects of appurtenances (accessories).

The A-weighted sound ratings shown have been calculated per AMCA International Standard 301. Values shown are for outlet LwoA sound power levels for installation Type C: ducted inlet, free outlet. NB: CHEM HE50 & HDE90 is not licensed to bear the AMCA certified rating seal.



Introducing the Fan Energy Index

The FEI is a ratio of the actual fan efficiency to a baseline fan efficiency, both calculated at a given airflow and pressure point (FEI_s is calculated using a static pressure basis, FEI_t is calculated using a total pressure basis). Since these efficiencies are each calculated at the same airflow and pressure, FEI is also defined as the ratio of the baseline electrical power to the actual electrical power of a fan.

The FEI was designed to encourage responsible application of fans and drive significant and quantifiable energy savings through energy codes, utility rebate programs and federal regulations. This is accomplished by establishing the minimum fan efficiency or maximum fan electrical input power at design airflow and pressure. The FEI can be used by:

- ▶ Regulators to improve the efficiency of fan designs and limit market availability of less efficient fans
- ▶ Utilities to establish rebate programs to incentivize the efficient use of fans
- ▶ Code bodies to drive building owners and contractors to using more energy efficient fans for ventilation and process applications
- ▶ Purchasing agents to evaluate the fan selections and their suitability for specific applications

Selection Example

The **belt driven** centrifugal fan **CHEM HS30 200** with three-phase **50 Hz** motor power supply, by plotting the FEI curve as per the right graph, the FEI_t value will be 0.98 under the duty **1,000 CMH** airflow, **923 Pa total pressure** running at **1,800 rpm**.

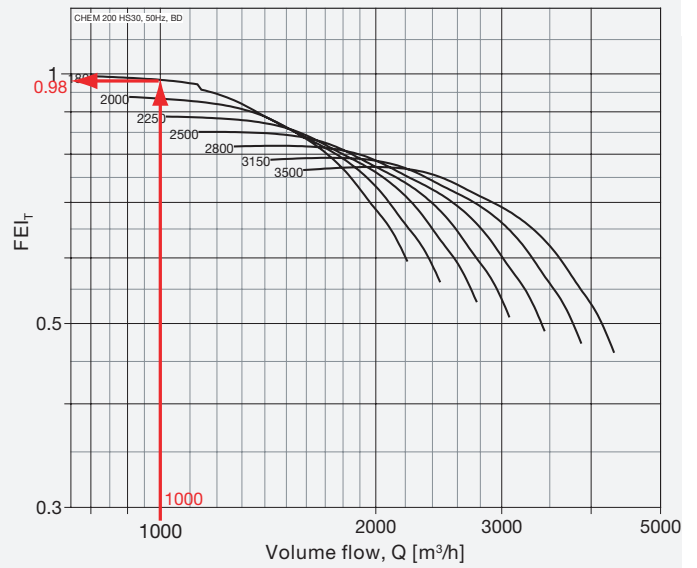

HS30 Series, Belt Driven, Size from 200 to 1000, 50Hz

Model: CHEM HS30 200

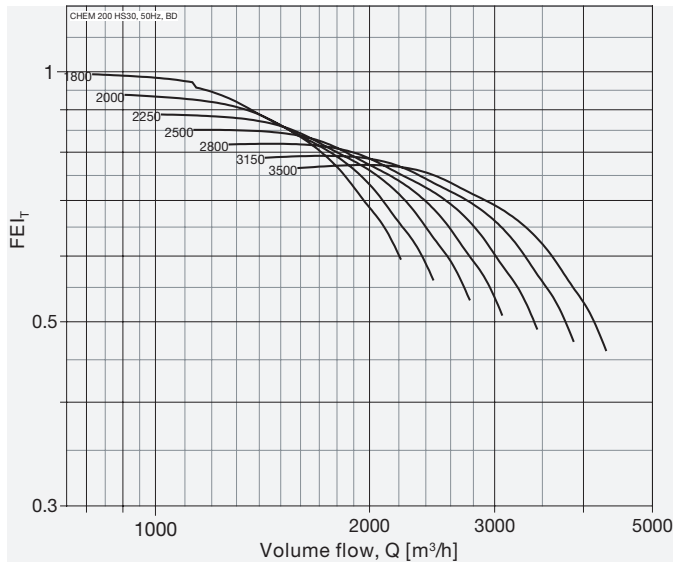

Model: CHEM HS30 225

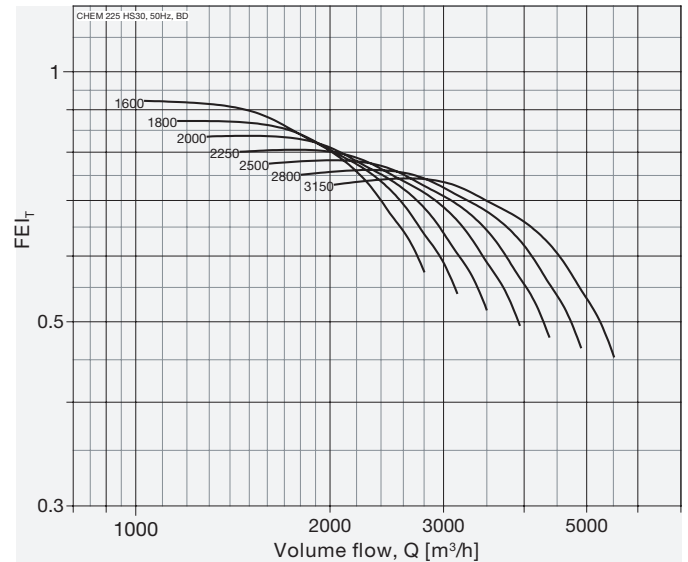

Model: CHEM HS30 250

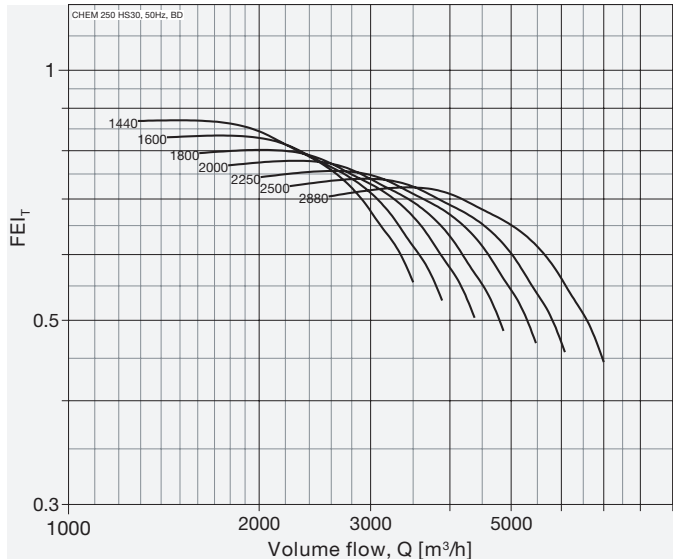

Model: CHEM HS30 280

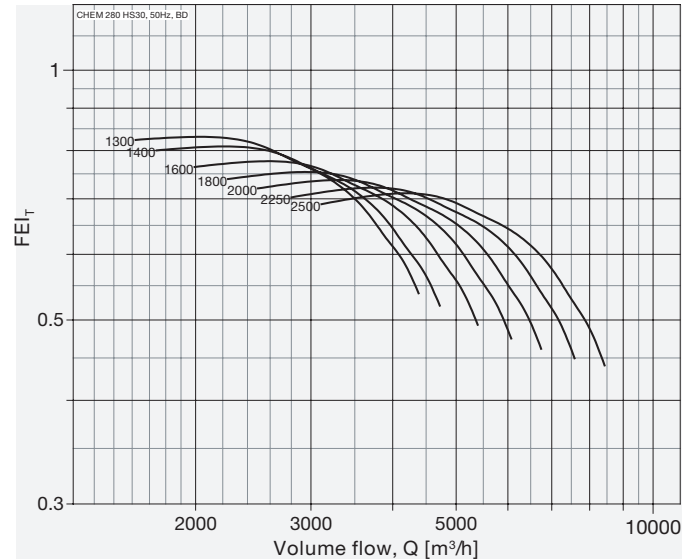

Fan test laboratory AMCA 210, 260 & 300. Performance certified is for installation type C - Ducted inlet, Free outlet. Power rating (kW) does not include transmission losses. Performance ratings do not include the effects of cross winds. Performance ratings do not include the effects of appurtenances (accessories). FEI_s values are calculated in accordance with ANSI/AMCA Standard 208 and are based on default motor efficiencies (Belt Driven type). FEI_t values for fans with specific motors will vary slightly from those shown. Fan speed shown in RPM.



Model: CHEM HS30 315

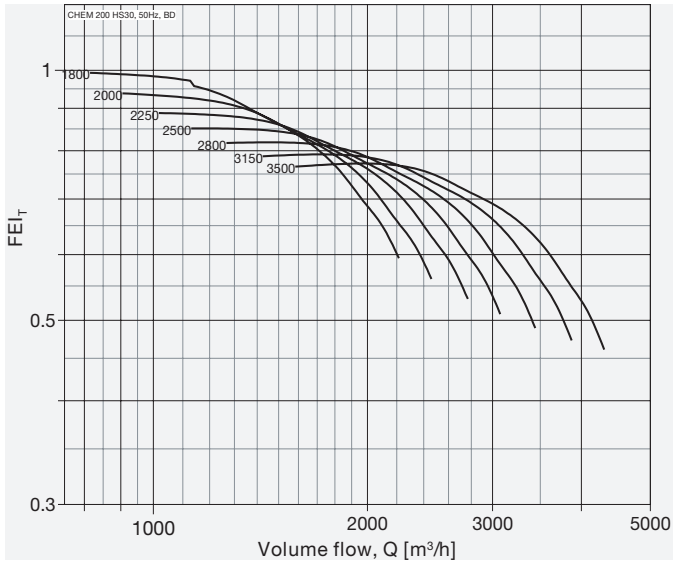

Model: CHEM HS30 355

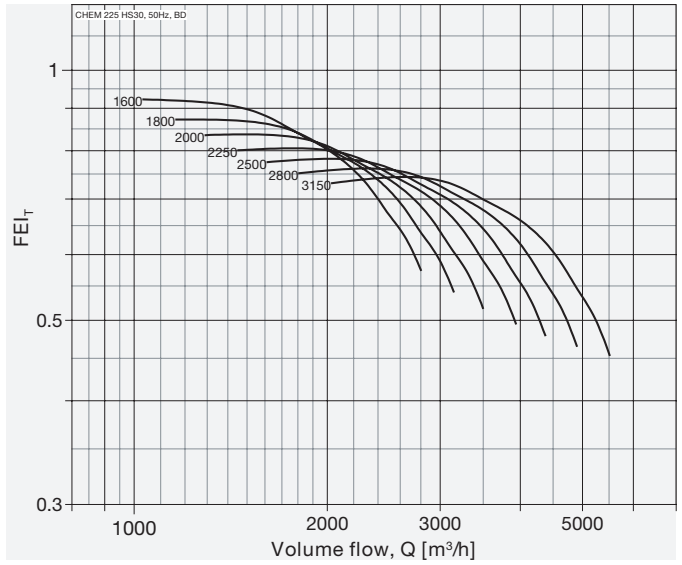

Model: CHEM HS30 400

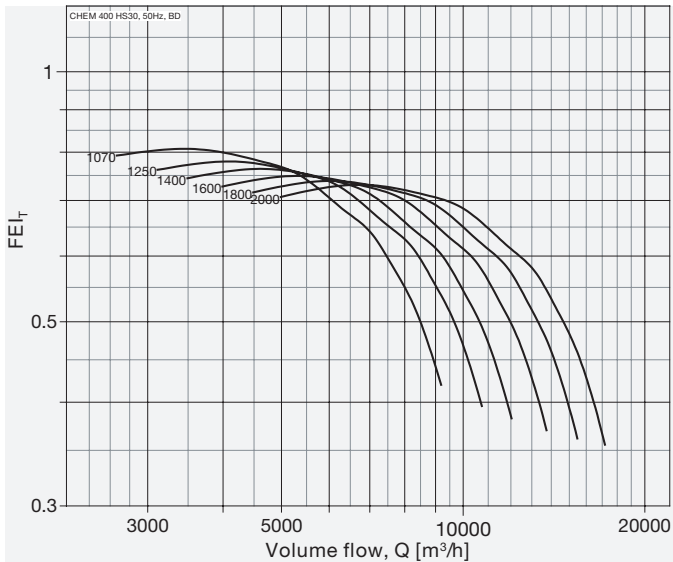

Model: CHEM HS30 450

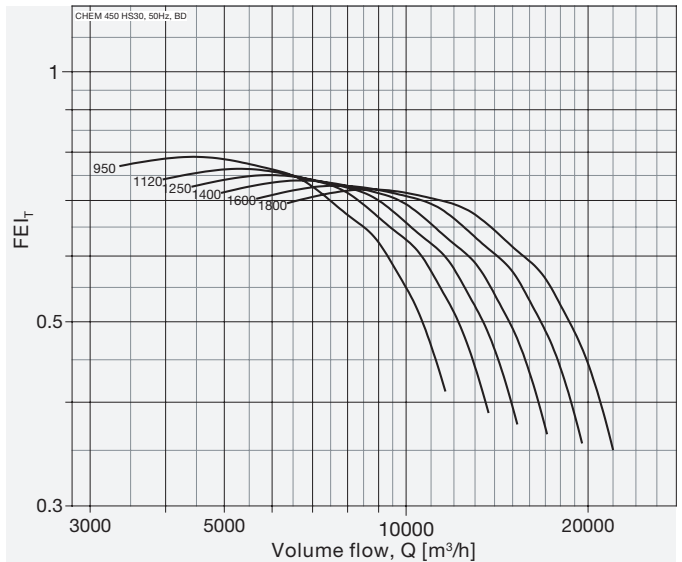

Model: CHEM HS30 500

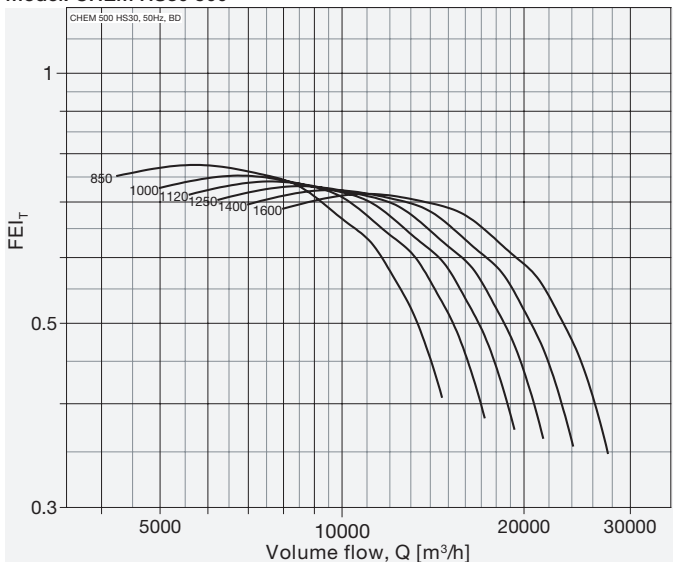

Model: CHEM HS30 560

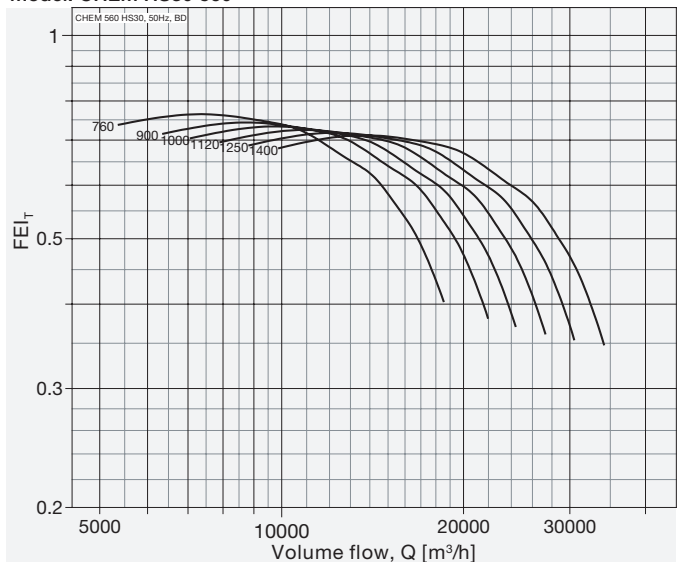

Fan test laboratory AMCA 210, 260 & 300. Performance certified is for installation type C - Ducted inlet, Free outlet. Power rating (kW) does not include transmission losses. Performance ratings do not include the effects of cross winds. Performance ratings do not include the effects of appurtenances (accessories). FEI_T values are calculated in accordance with ANSI/AMCA Standard 208 and are based on default motor efficiencies (Belt Driven type). FEI_T values for fans with specific motors will vary slightly from those shown. Fan speed shown in RPM.



Model: CHEM HS30 630

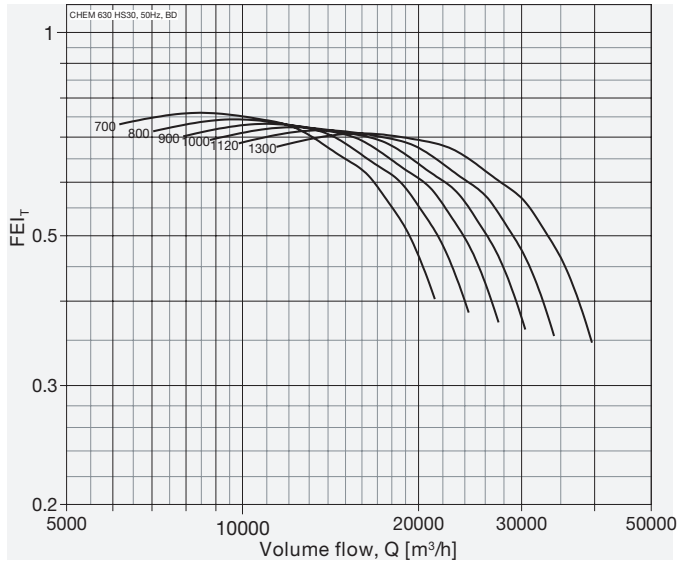

Model: CHEM HS30 710

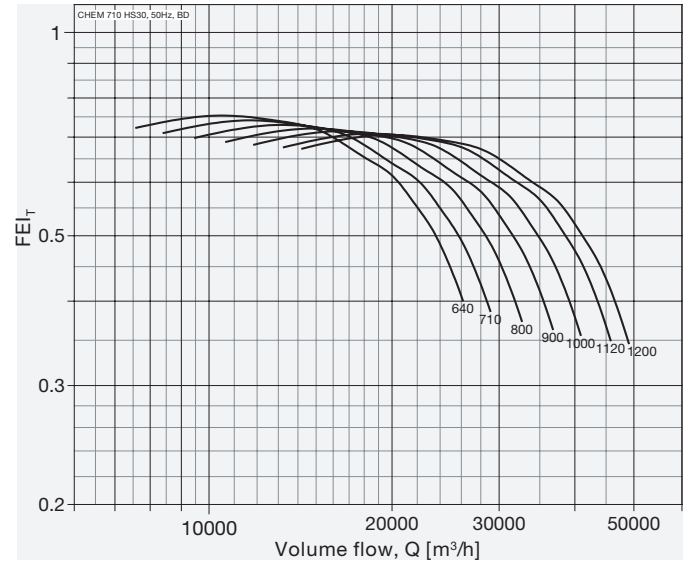

Model: CHEM HS30 800

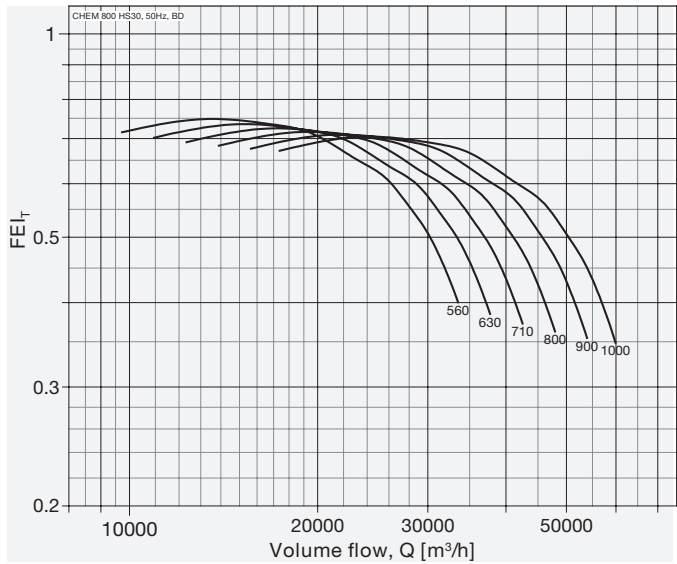

Model: CHEM HS30 900

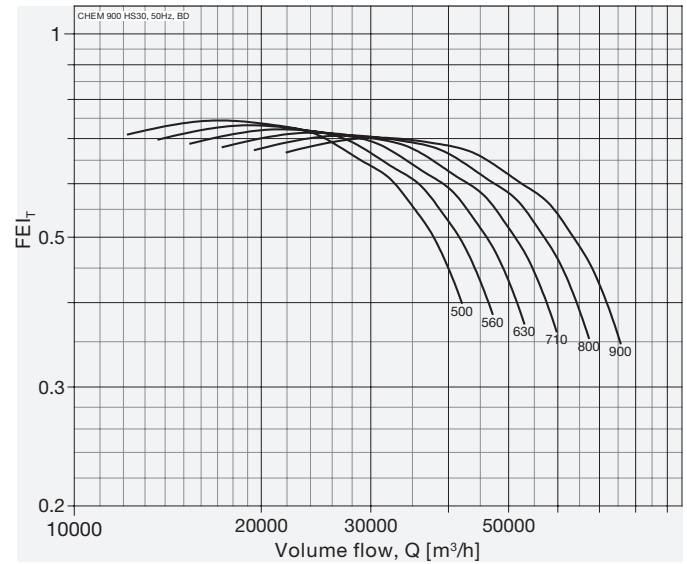

Model: CHEM HS30 1000

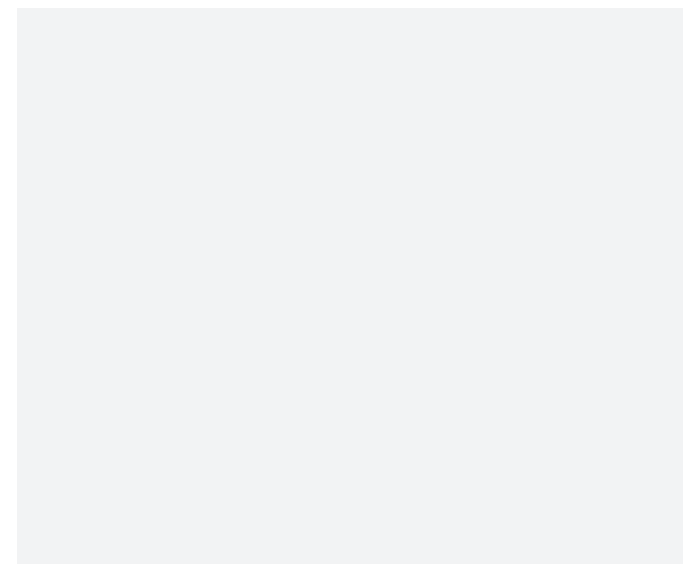
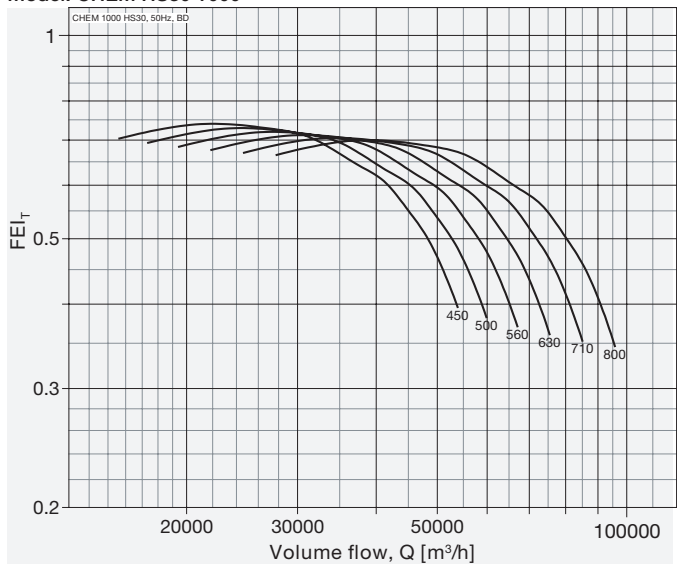

Fan test laboratory AMCA 210, 260 & 300. Performance certified is for installation type C - Ducted inlet, Free outlet. Power rating (kW) does not include transmission losses. Performance ratings do not include the effects of cross winds. Performance ratings do not include the effects of appurtenances (accessories). FEI_T values are calculated in accordance with ANSI/AMCA Standard 208 and are based on default motor efficiencies (Belt Driven type). FEI_T values for fans with specific motors will vary slightly from those shown. Fan speed shown in RPM.



Model: CHEM HE30 200

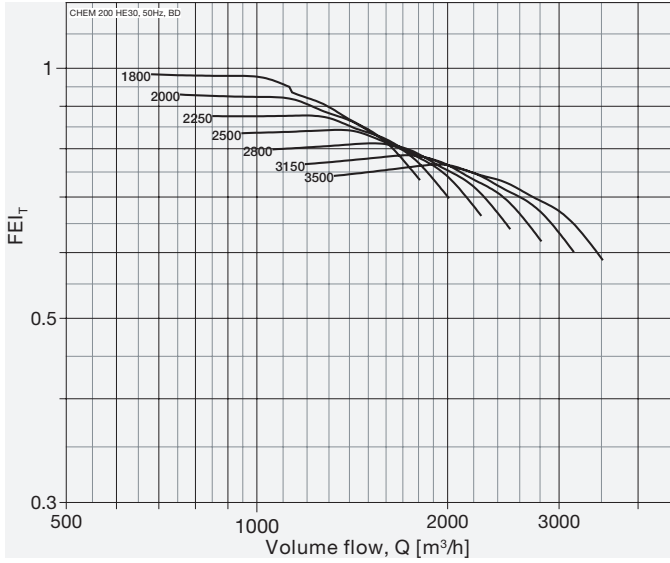

Model: CHEM HE30 225

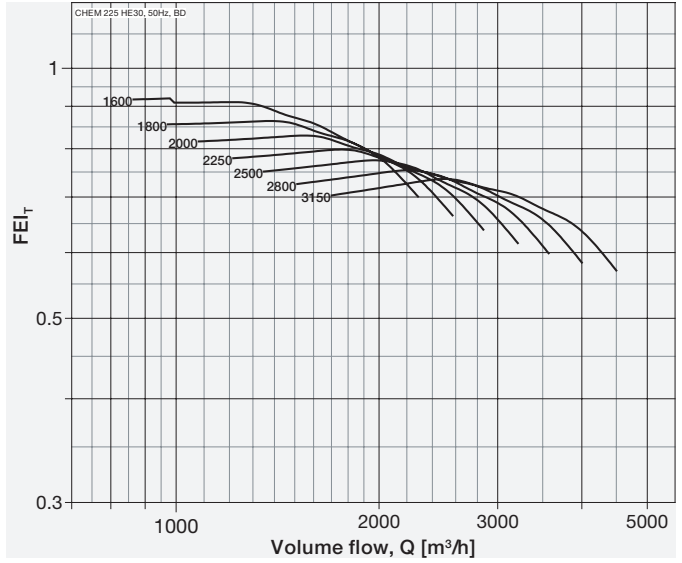

Model: CHEM HE30 250

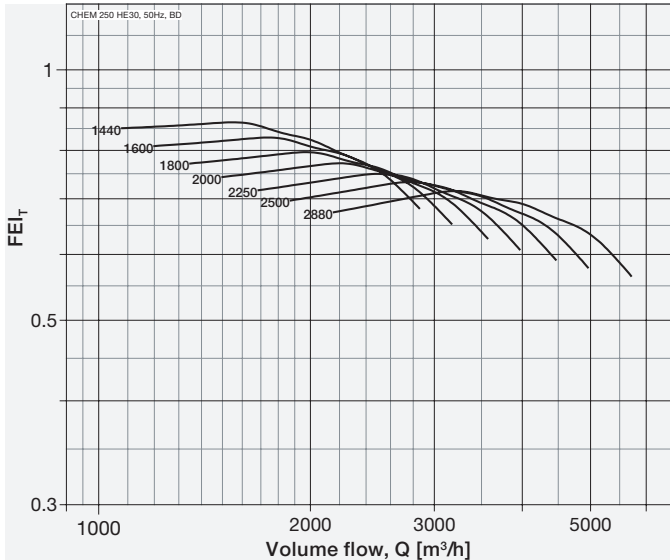

Model: CHEM HE30 280

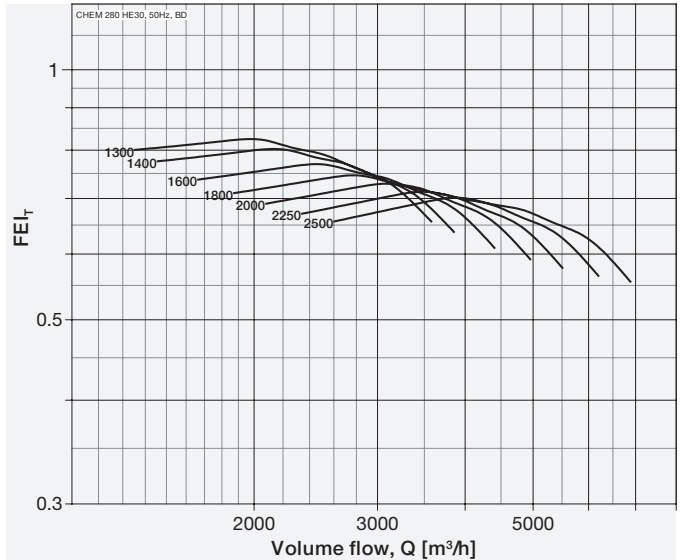

Model: CHEM HE30 315

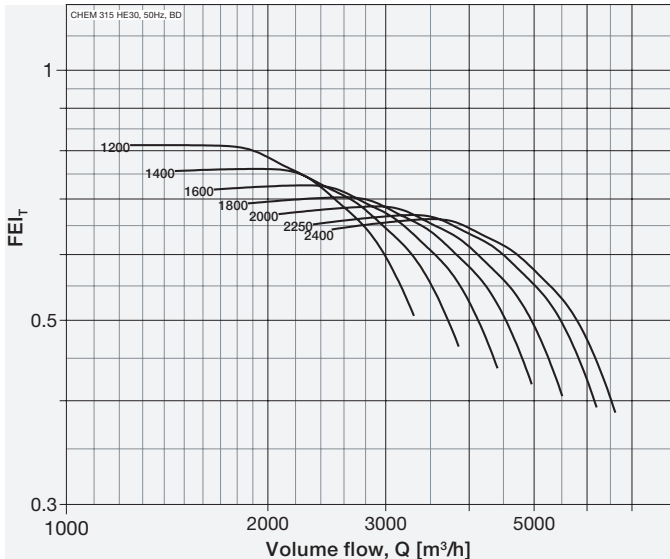

Model: CHEM HE30 355

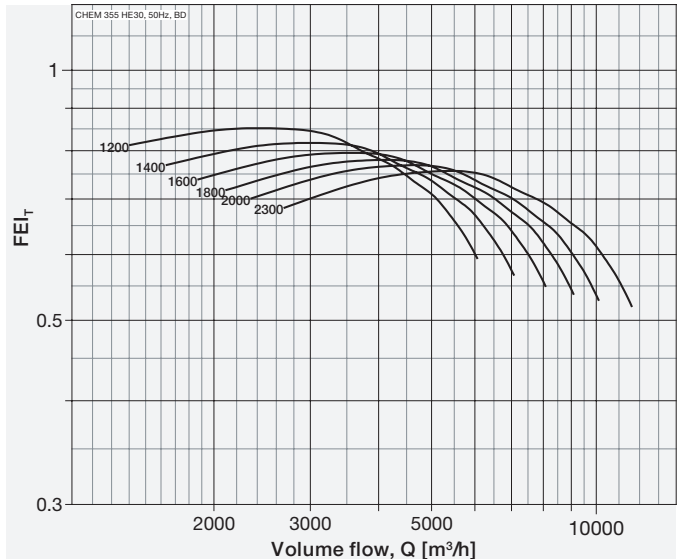

Fan test laboratory AMCA 210, 260 & 300. Performance certified is for installation type C - Ducted inlet, Free outlet. Power rating (kW) does not include transmission losses. Performance ratings do not include the effects of cross winds. Performance ratings do not include the effects of appurtenances (accessories). FEI_T values are calculated in accordance with ANSI/AMCA Standard 208 and are based on default motor efficiencies (Belt Driven type). FEI_T values for fans with specific motors will vary slightly from those shown. Fan speed shown in RPM.



Fan Energy Index

HE30 Series Belt Driven, 50Hz



Model: CHEM HE30 400

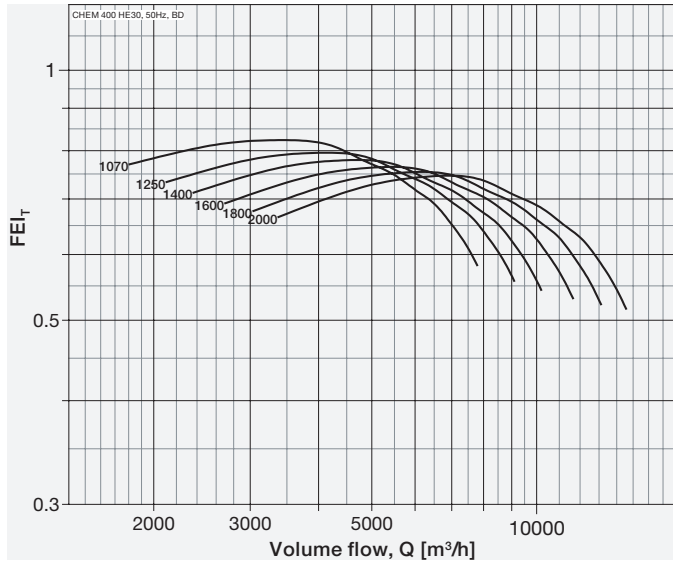

Model: CHEM HE30 450

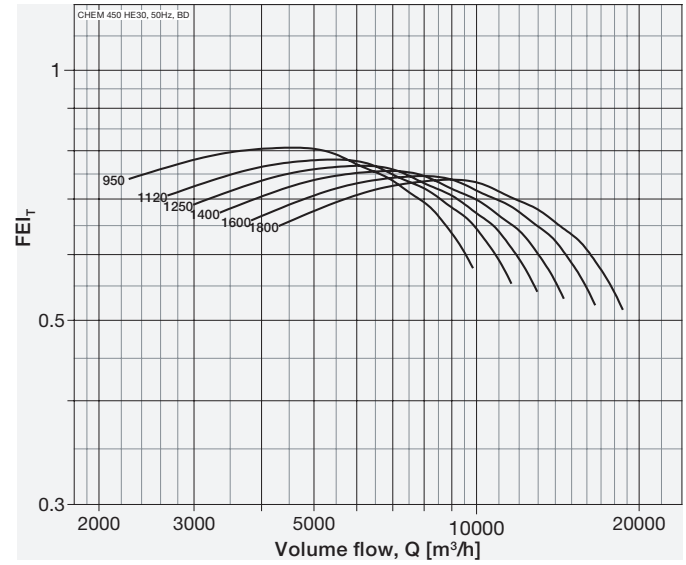

Model: CHEM HE30 500

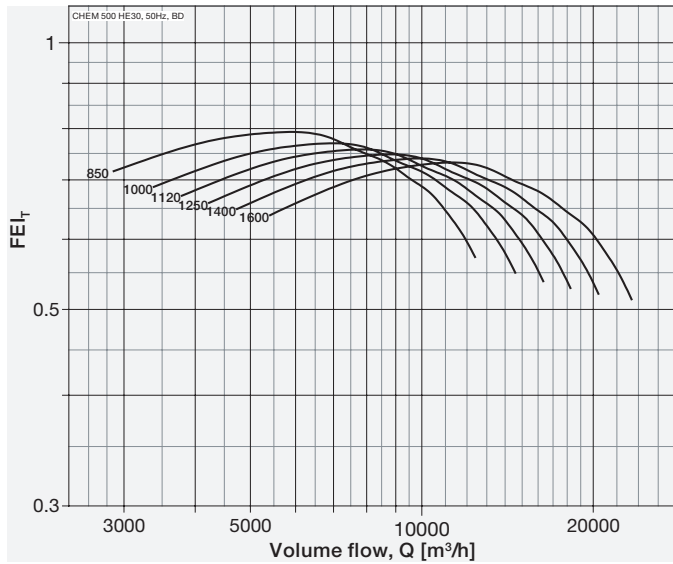

Model: CHEM HE30 560

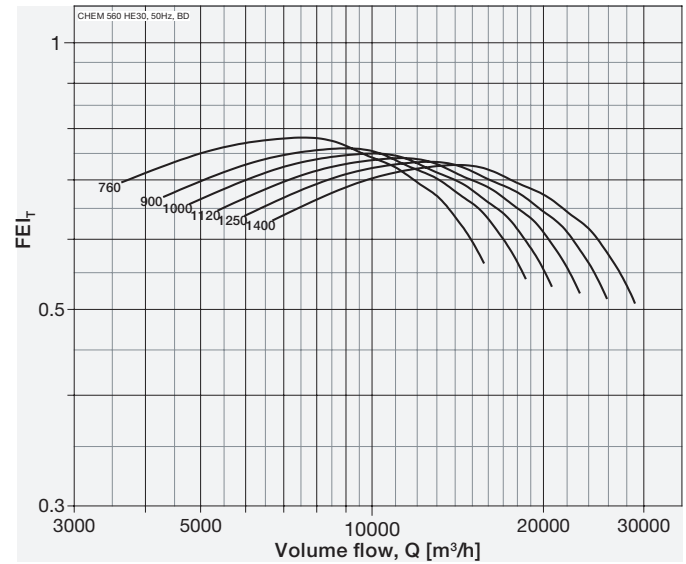

Model: CHEM HE30 630

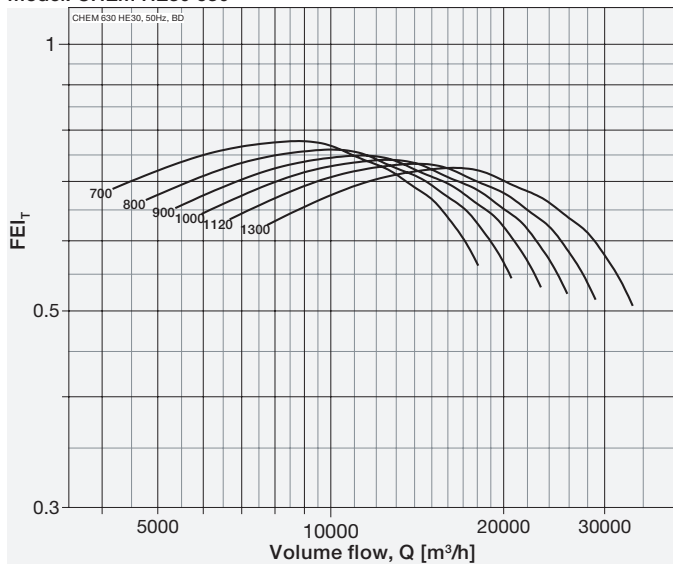

Model: CHEM HE30 710

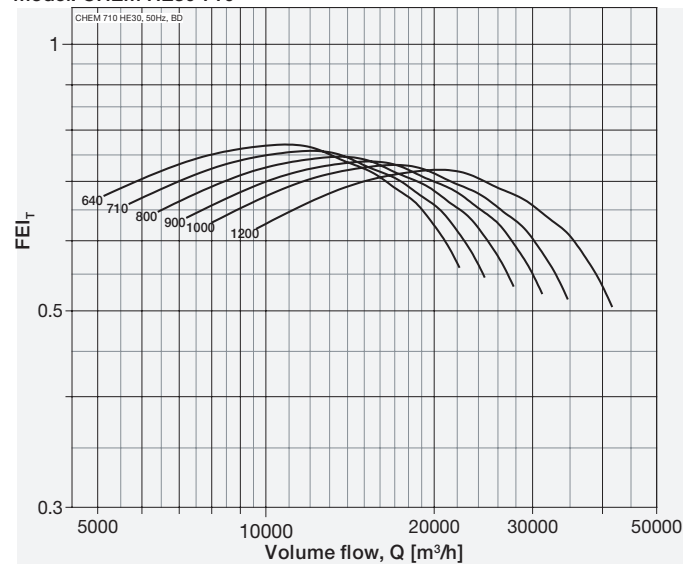

Fan test laboratory AMCA 210, 260 & 300. Performance certified for installation type C - Ducted inlet, Free outlet. Power rating (kW) does not include transmission losses. Performance ratings do not include the effects of cross winds. Performance ratings do not include the effects of appurtenances (accessories). FEI_T values are calculated in accordance with ANSI/AMCA Standard 208 and are based on default motor efficiencies (Belt Driven type). FEI_T values for fans with specific motors will vary slightly from those shown. Fan speed shown in RPM.



Fan Energy Index

HE30 Series Belt Driven, 50Hz



Model: CHEM HE30 800

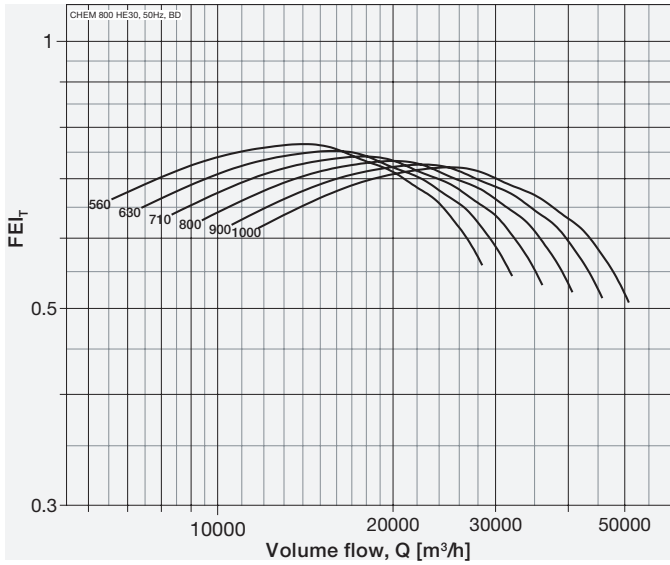

Model: CHEM HE30 900

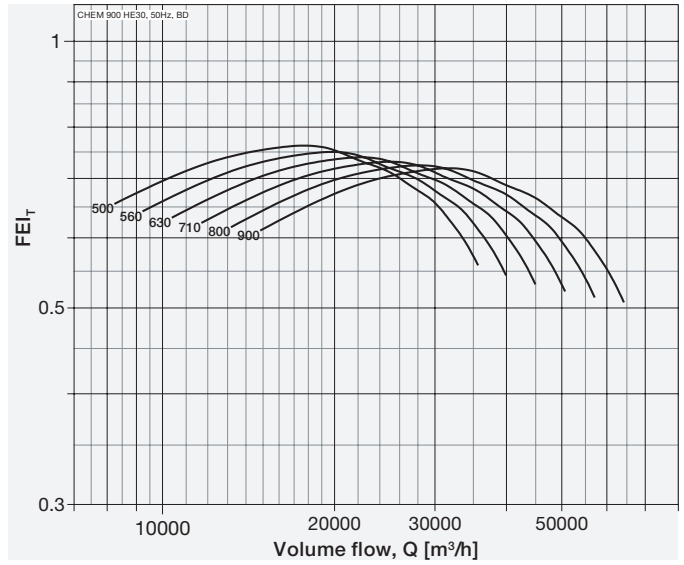

Model: CHEM HE30 1000

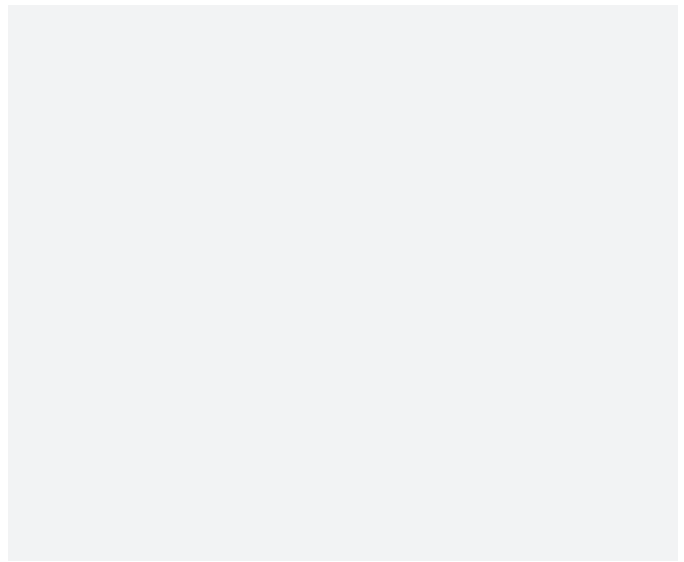
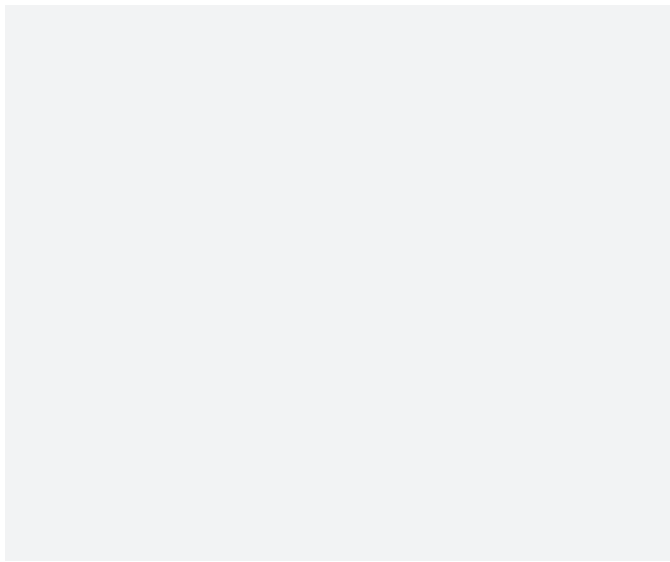
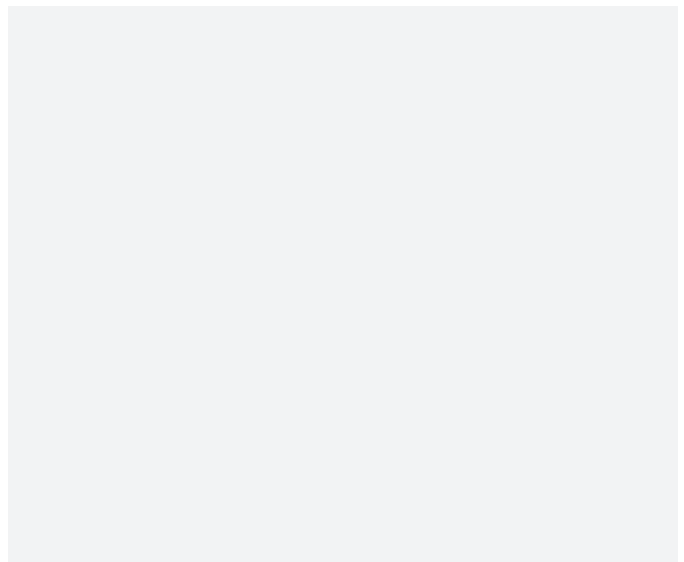
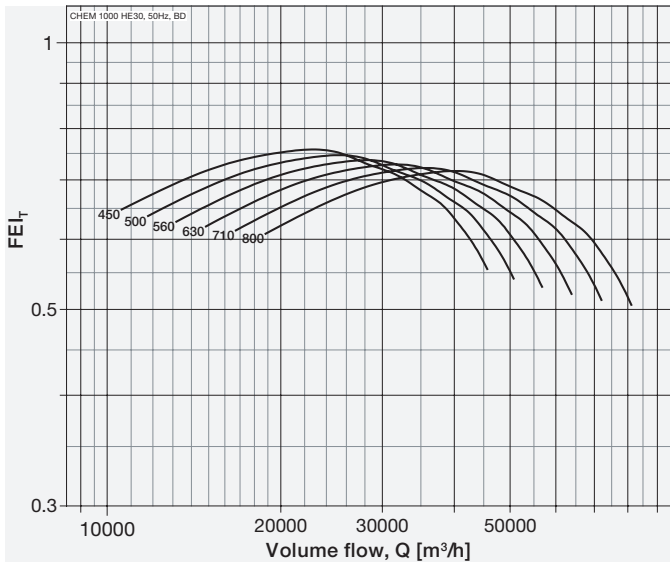

Fan test laboratory AMCA 210, 260 & 300. Performance certified is for installation type C - Ducted inlet, Free outlet. Power rating (kW) does not include transmission losses. Performance ratings do not include the effects of cross winds. Performance ratings do not include the effects of appurtenances (accessories). FEI_T values are calculated in accordance with ANSI/AMCA Standard 208 and are based on default motor efficiencies (Belt Driven type). FEI_T values for fans with specific motors will vary slightly from those shown. Fan speed shown in RPM.

HE50 Series

Belt Driven, 50Hz



Fan Energy Index

Model: CHEM HE50 250

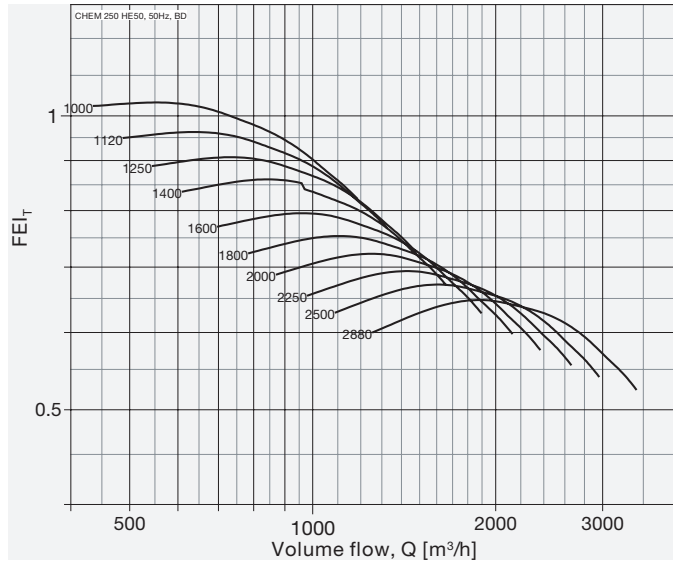

Model: CHEM HE50 315

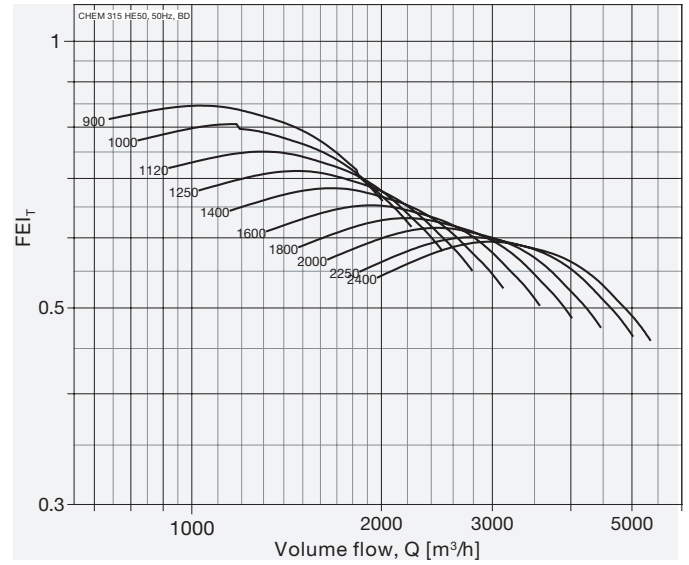

Model: CHEM HE50 355

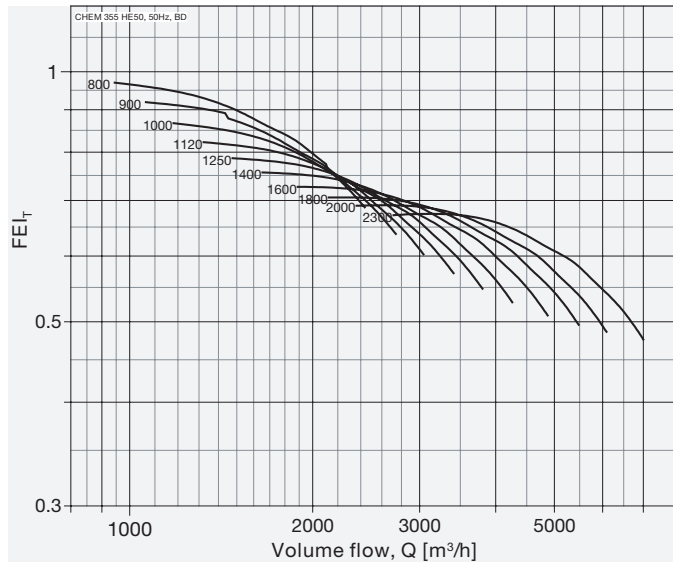

Model: CHEM HE50 400

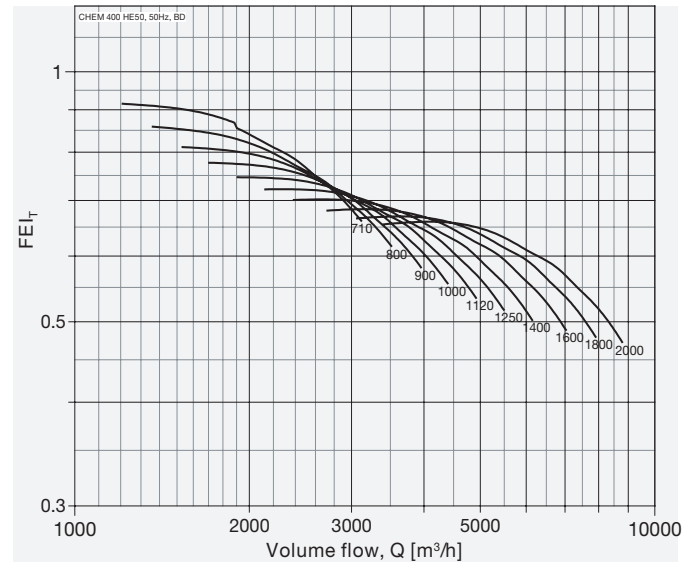

Model: CHEM HE50 450

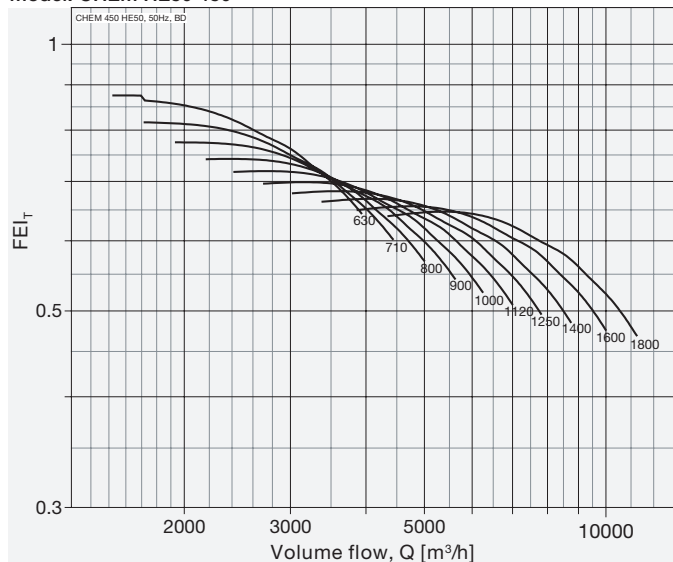

Model: CHEM HE50 500

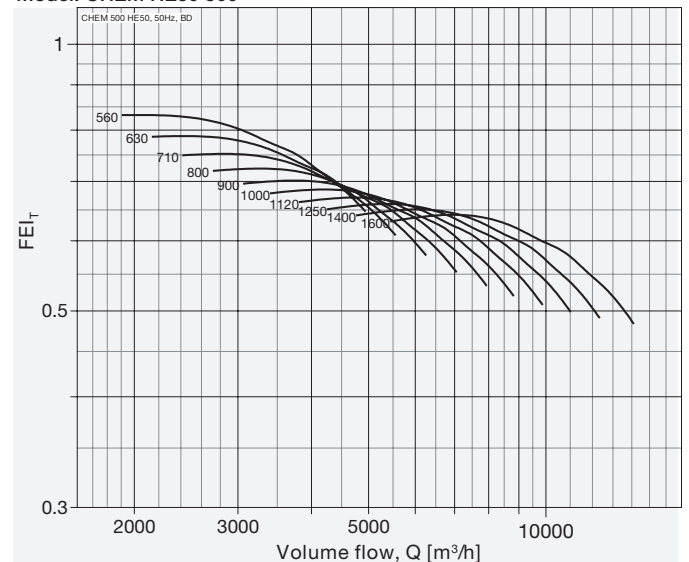

Fan test laboratory AMCA 210, 260 & 300. Performance is for installation type C - Ducted inlet, Free outlet. Power rating (kW) does not include transmission losses. Performance ratings do not include the effects of cross winds. Performance ratings do not include the effects of appurtenances (accessories). FEI_T values are calculated in accordance with ANSI/AMCA Standard 208 and are based on default motor efficiencies (Belt Driven type). FEI_T values for fans with specific motors will vary slightly from those shown. Fan speed shown in RPM.
 NB: CHEM HE50 & HDE90 is not licensed to bear the AMCA certified rating seal.

Fan Energy Index

HE50 Series Belt Driven, 50Hz



Model: CHEM HE50 560

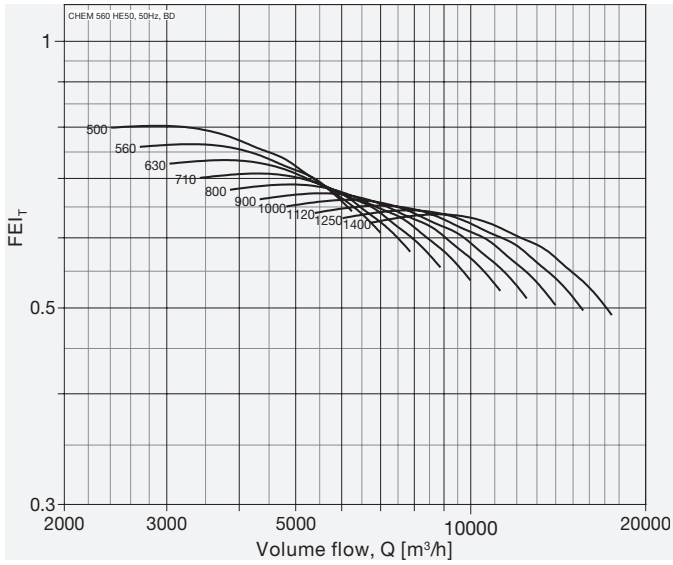

Model: CHEM HE50 630

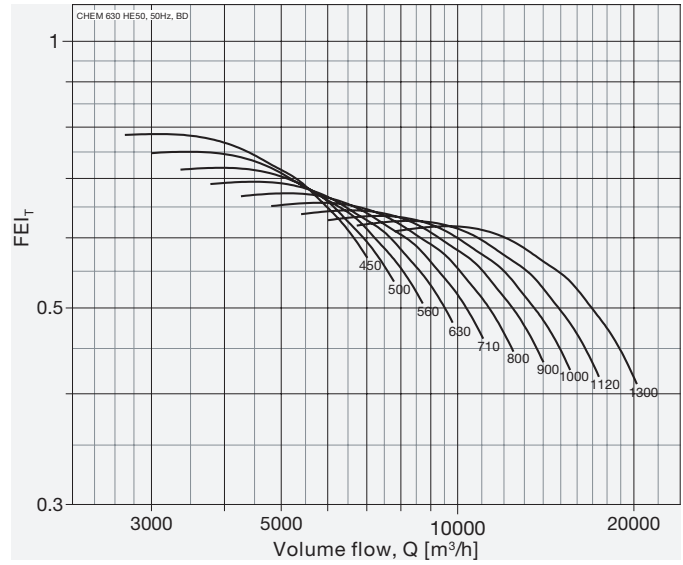

Model: CHEM HE50 710

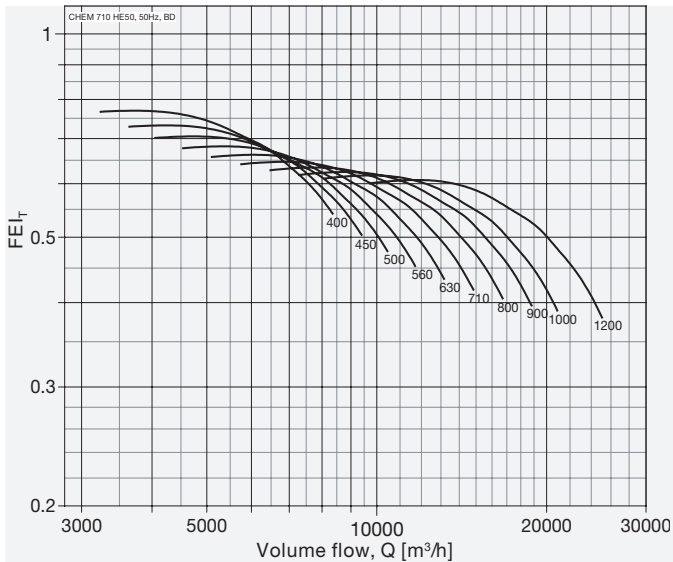

Model: CHEM HE50 800

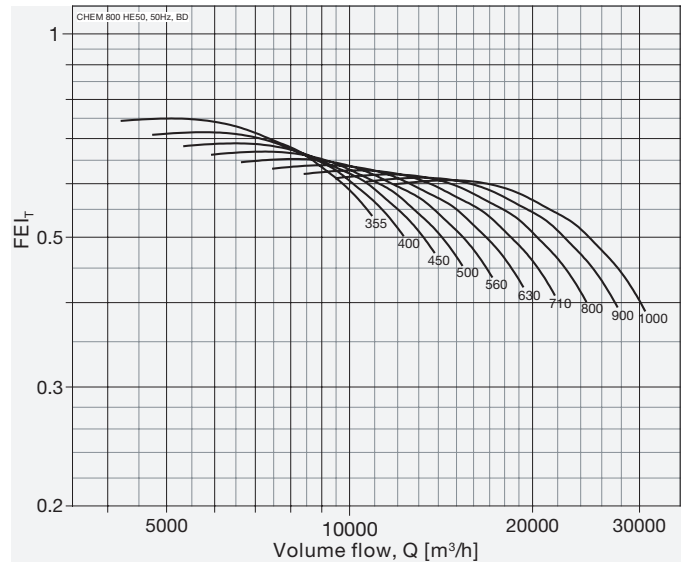

Model: CHEM HE50 900

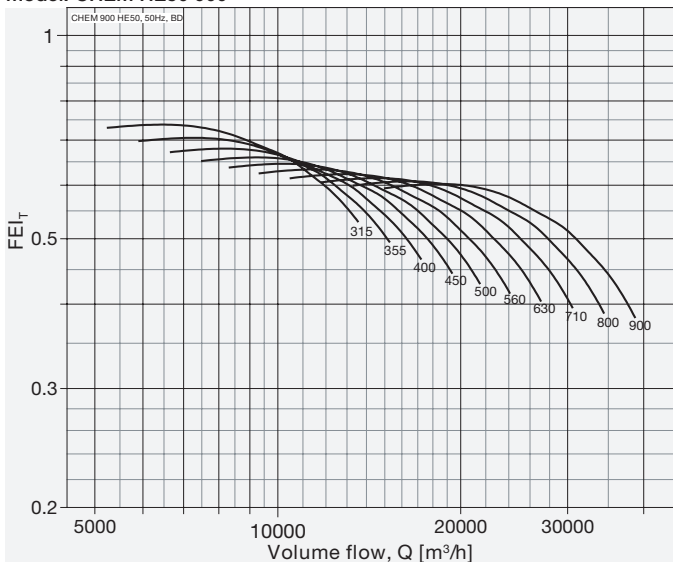

Model: CHEM HE50 1000

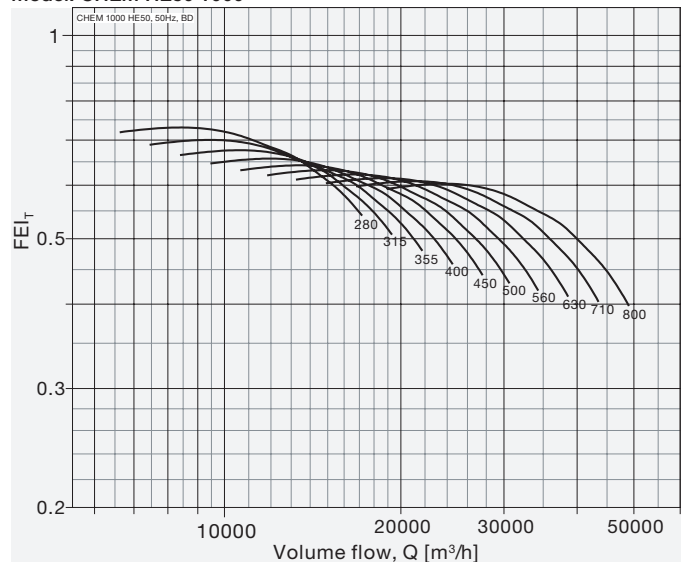

Fan test laboratory AMCA 210, 260 & 300. Performance is for installation type C - Ducted inlet, Free outlet. Power rating (kW) does not include transmission losses. Performance ratings do not include the effects of cross winds. Performance ratings do not include the effects of appurtenances (accessories). FEI_T values are calculated in accordance with ANSI/AMCA Standard 208 and are based on default motor efficiencies (Belt Driven type). FEI_T values for fans with specific motors will vary slightly from those shown. Fan speed shown in RPM.
NB: CHEM HE50 & HDE90 is not licensed to bear the AMCA certified rating seal.

Fan Energy Index

HDE90 Series Belt Driven, 50Hz



Model: CHEM HDE90 250

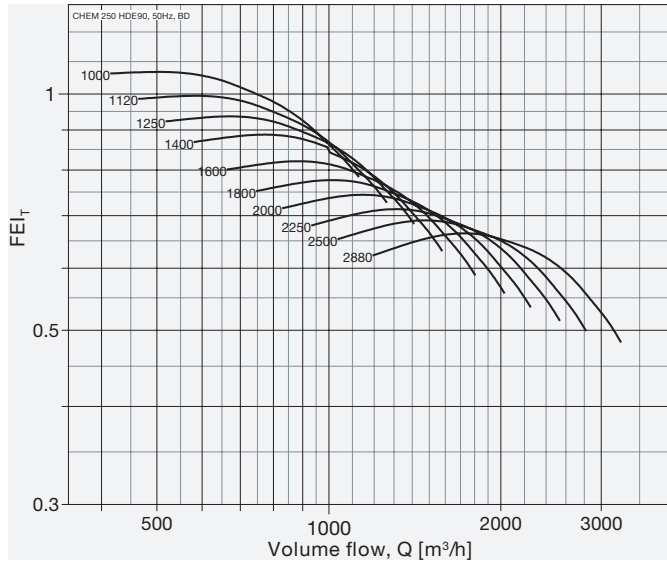

Model: CHEM HDE90 315

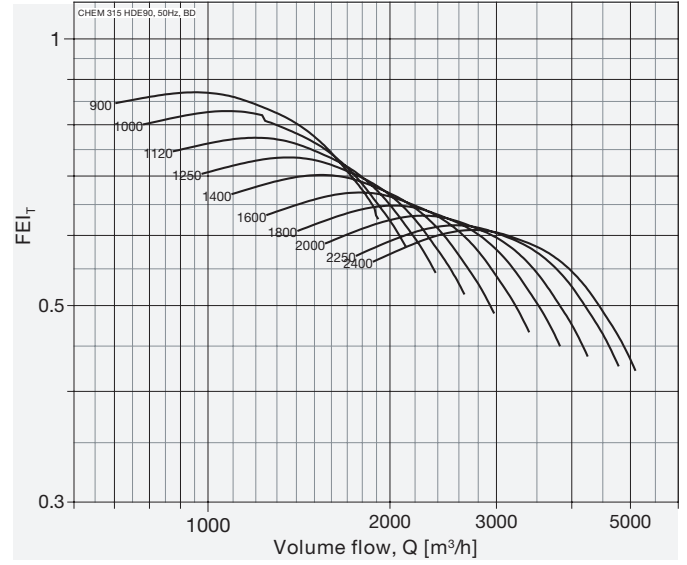

Model: CHEM HDE90 355

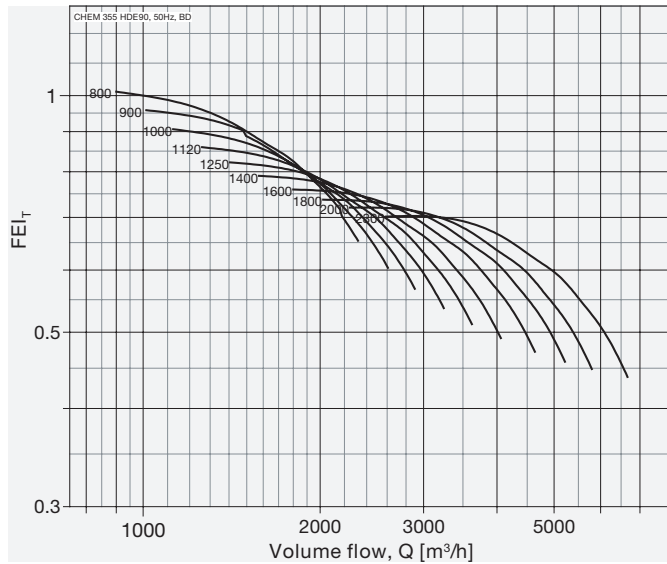

Model: CHEM HDE90 400

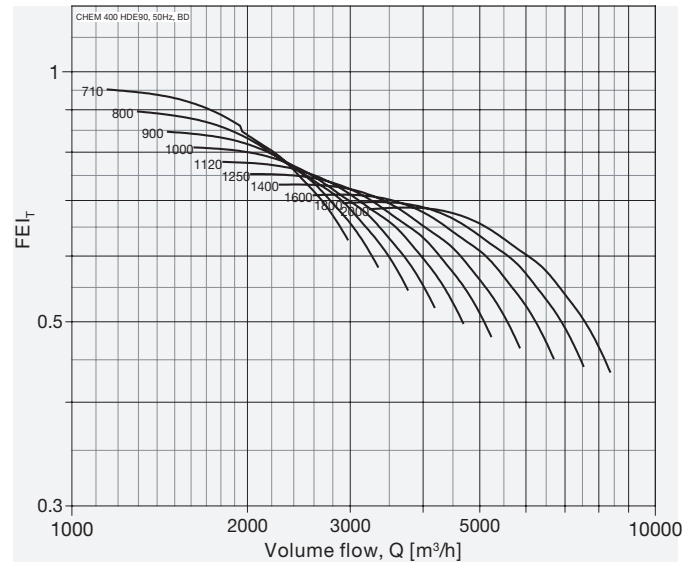

Model: CHEM HDE90 450

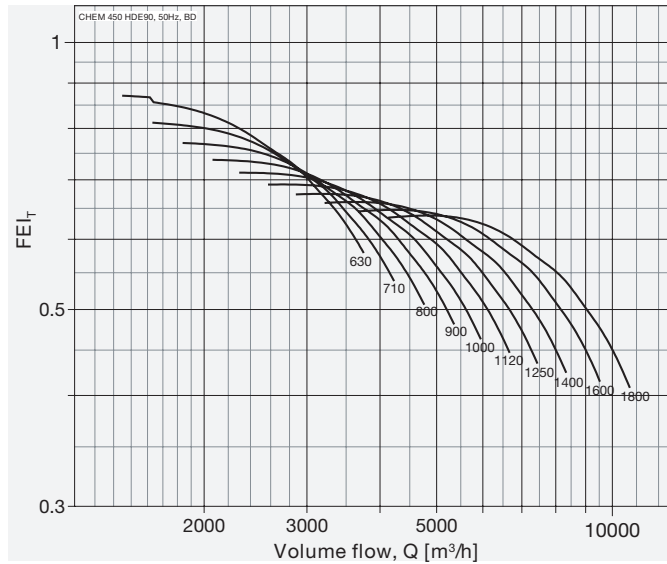

Model: CHEM HDE90 500

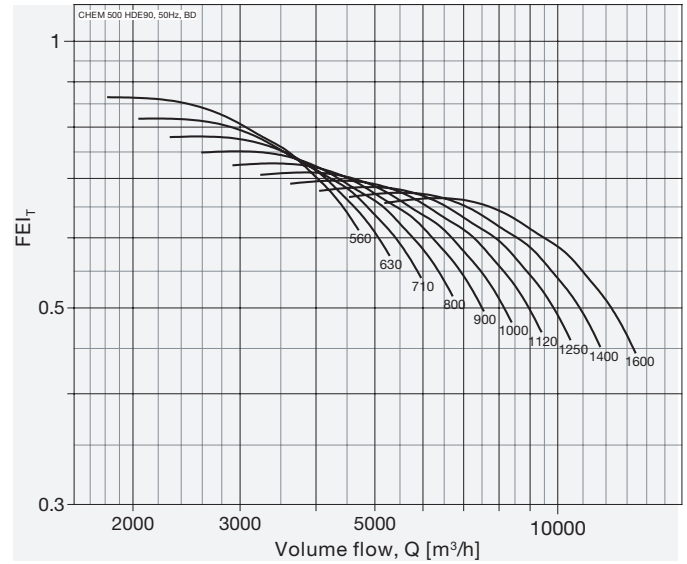

Fan test laboratory AMCA 210, 260 & 300. Performance is for installation type C - Ducted inlet, Free outlet. Power rating (kW) does not include transmission losses. Performance ratings do not include the effects of cross winds. Performance ratings do not include the effects of appurtenances (accessories). FEI_T values are calculated in accordance with ANSI/AMCA Standard 208 and are based on default motor efficiencies (Belt Driven type). FEI_T values for fans with specific motors will vary slightly from those shown. Fan speed shown in RPM.
NB: CHEM HE50 & HDE90 is not licensed to bear the AMCA certified rating seal.

Fan Energy Index

HDE90 Series Belt Driven, 50Hz



Model: CHEM HDE90 560

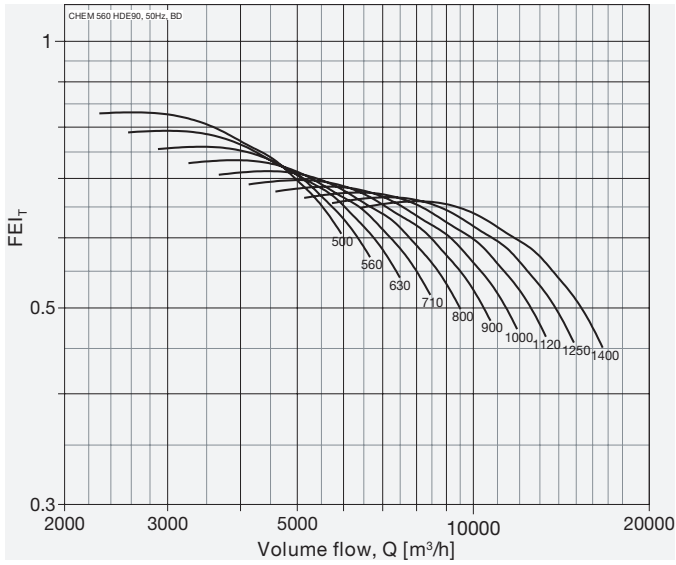

Model: CHEM HDE90 630

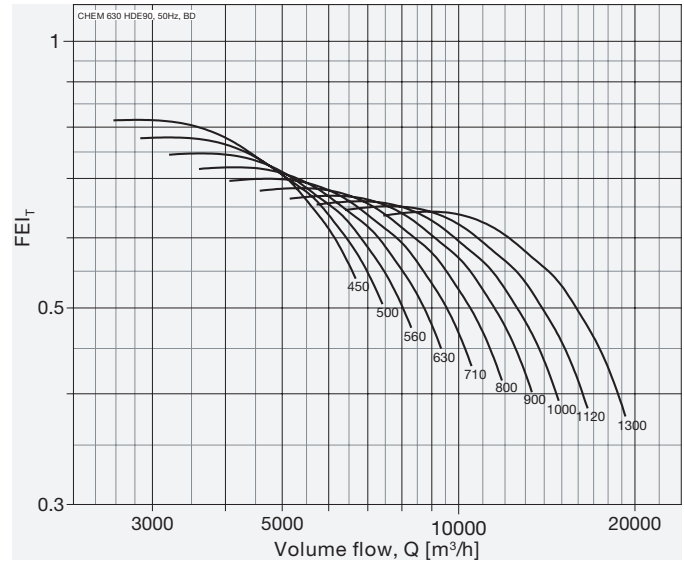

Model: CHEM HDE90 710

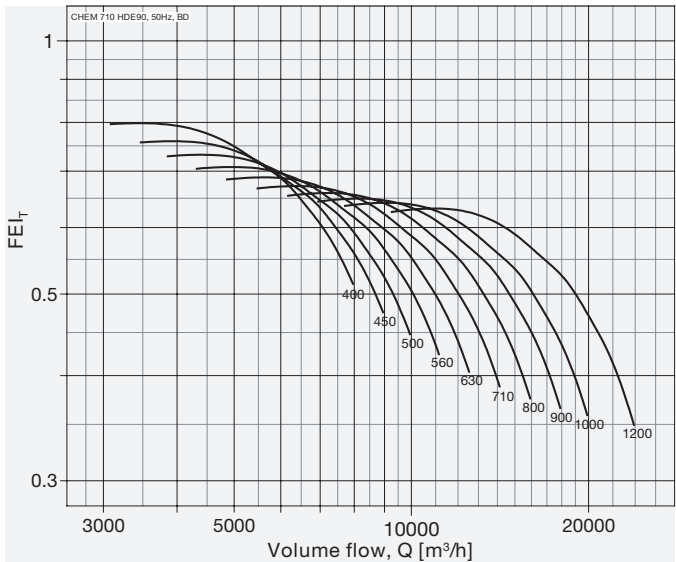

Model: CHEM HDE90 800

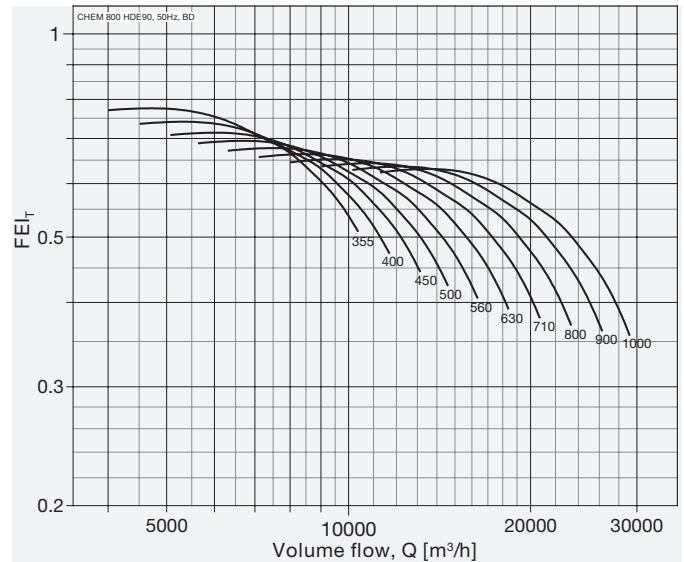

Model: CHEM HDE90 900

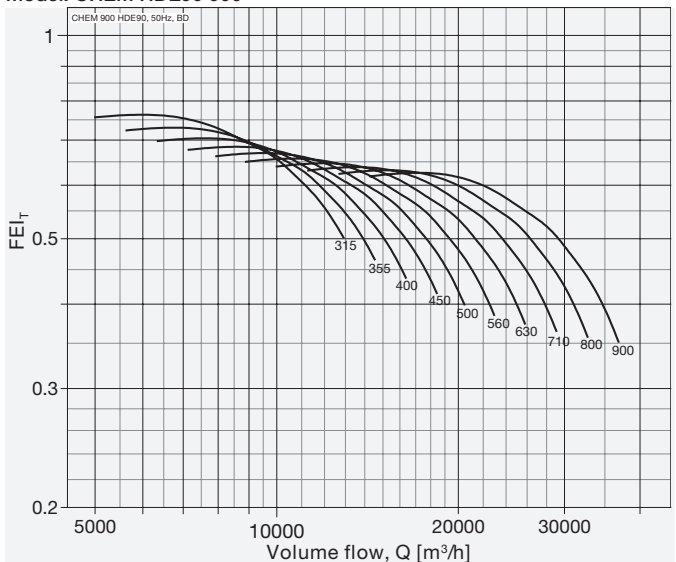

Model: CHEM HDE90 1000

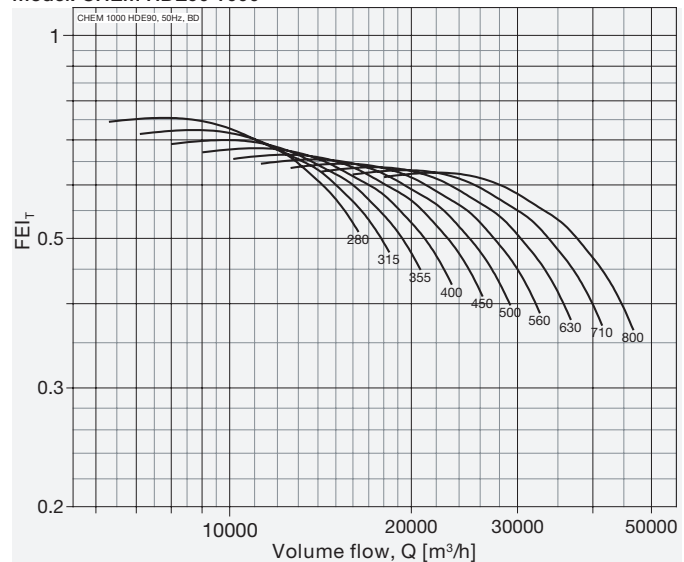

Fan test laboratory AMCA 210, 260 & 300. Performance is for installation type C - Ducted inlet, Free outlet. Power rating (kW) does not include transmission losses. Performance ratings do not include the effects of cross winds. Performance ratings do not include the effects of aperturances (accessories). FEI_T values are calculated in accordance with ANSI/AMCA Standard 208 and are based on default motor efficiencies (Belt Driven type). FEI_T values for fans with specific motors will vary slightly from those shown. Fan speed shown in RPM.
NB: CHEM HE50 & HDE90 is not licensed to bear the AMCA certified rating seal.

**Pressure Loss due to Jet Action (HS30 Type)
Fan Sizes CHEM 200 to 1000**

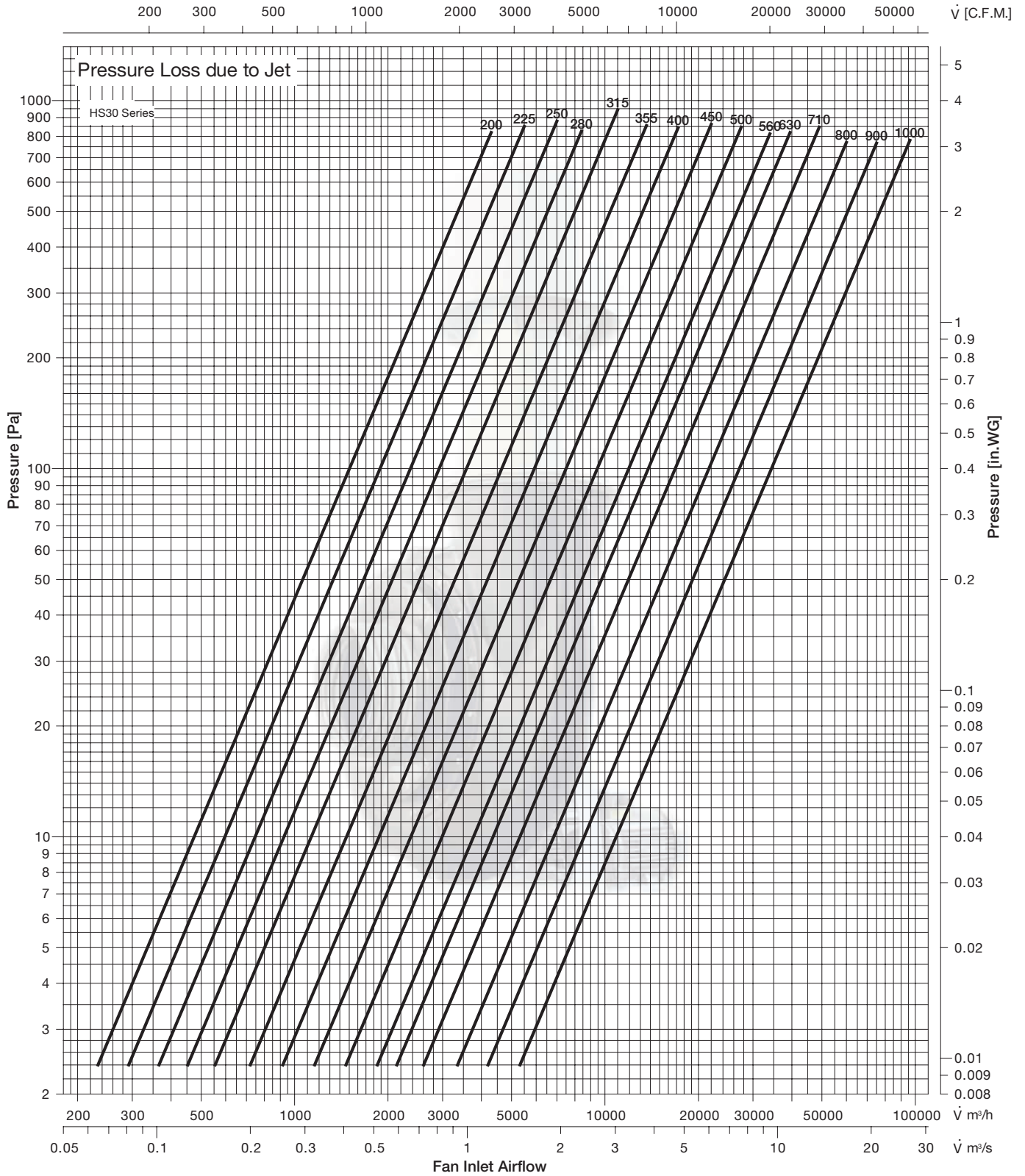

**Pressure Loss due to Jet Action (HE30 Type)
Fan Sizes CHEM 200 to 1000**

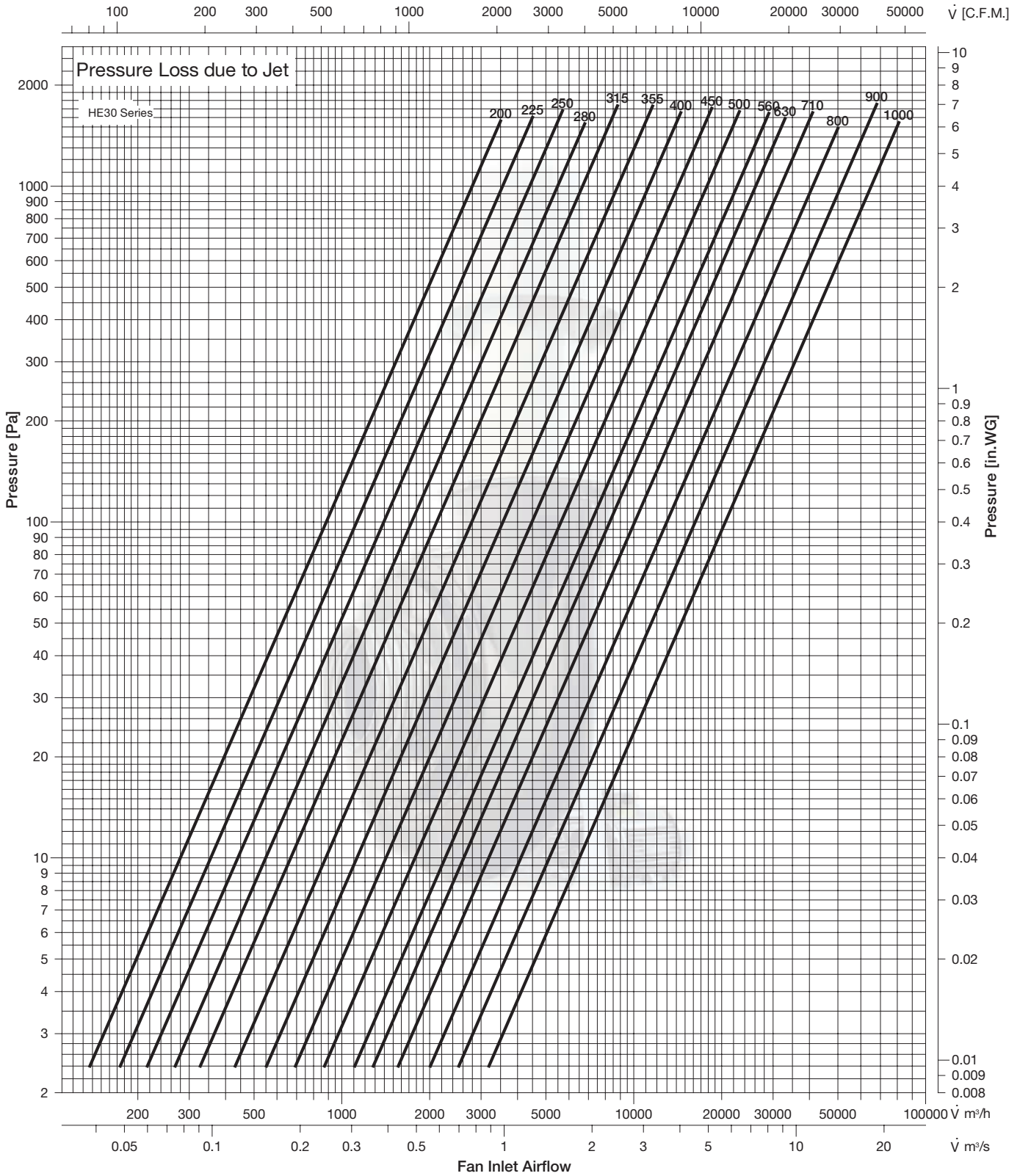

**Pressure Loss due to Jet Action (HE50 / HDE90 Type)
Fan Sizes CHEM 250 to 1000**

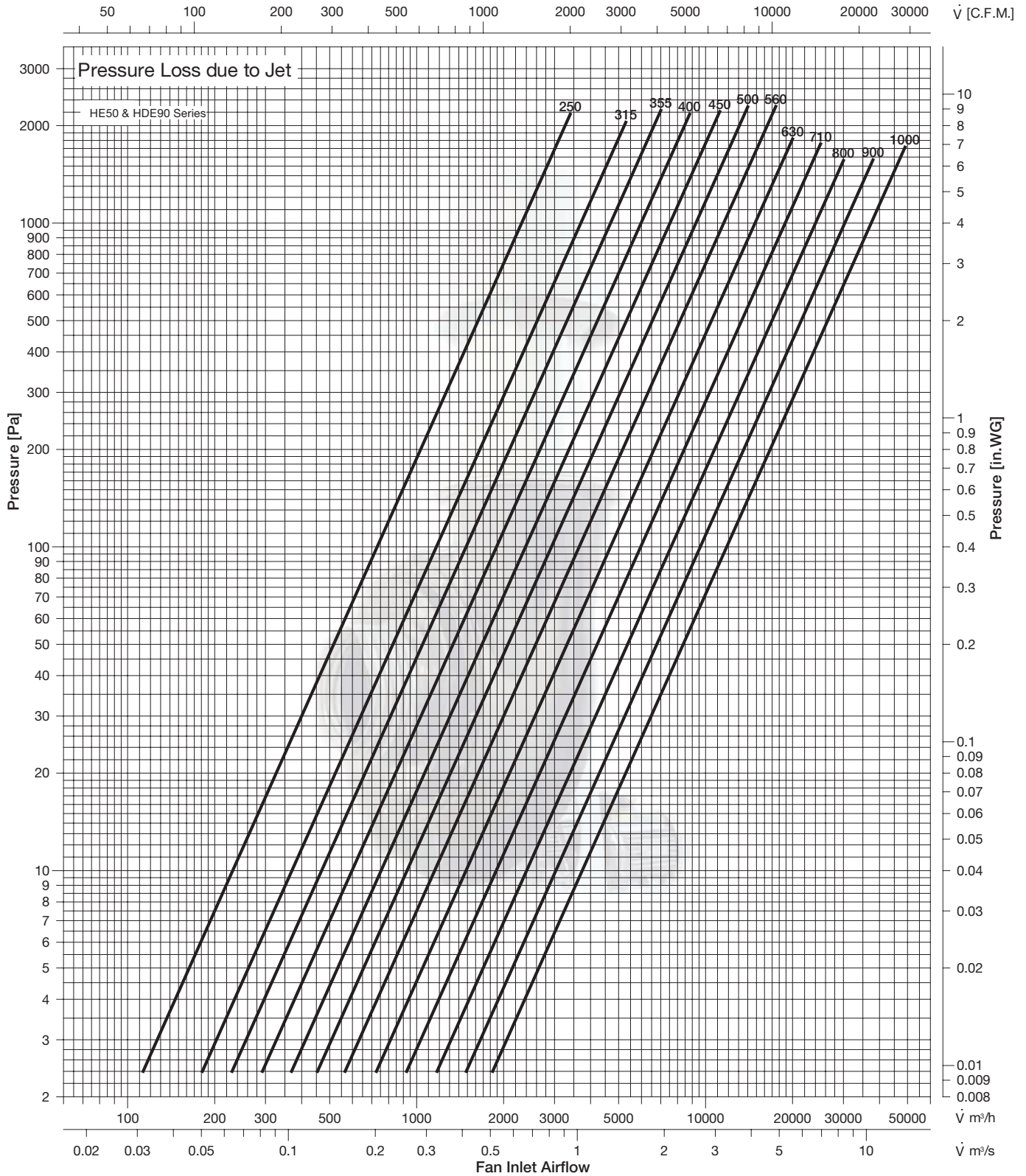

Effective Plume Rise h_r
 - HS30 Series, Fan Sizes CHEM 200 to 400

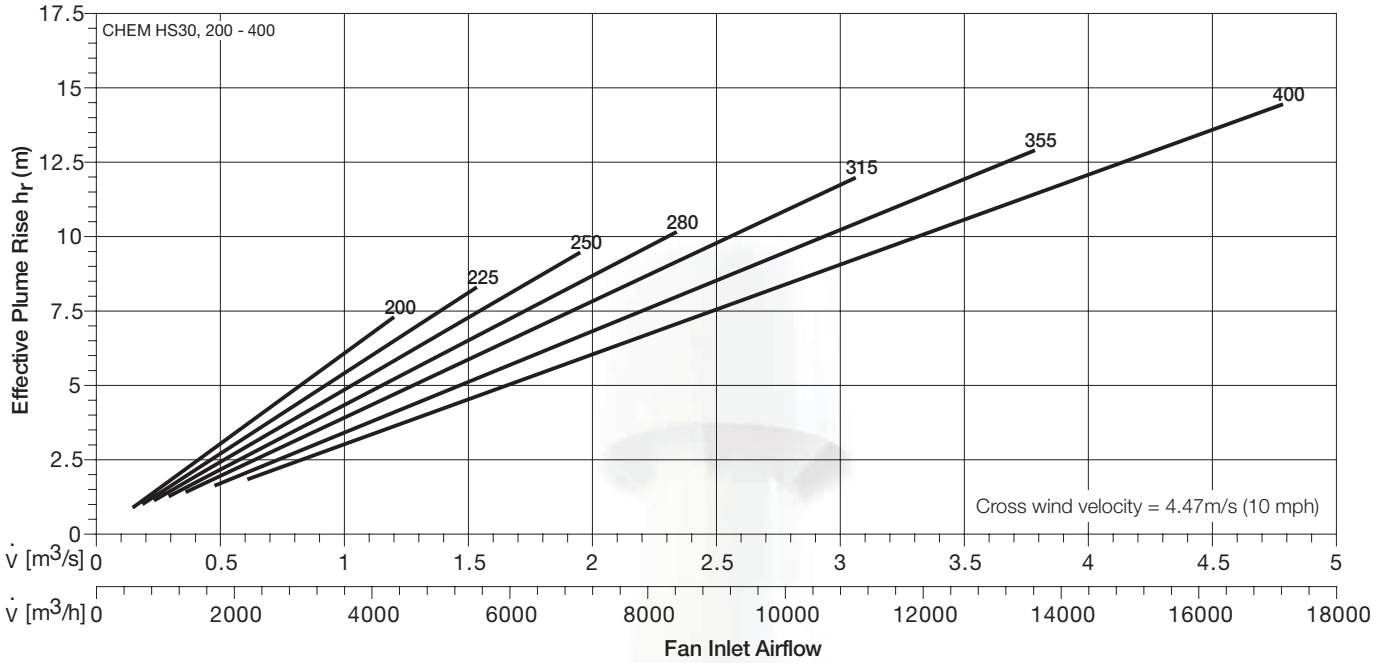

Effective Plume Rise h_r
 - HS30 Series, Fan Sizes CHEM 450 to 1000

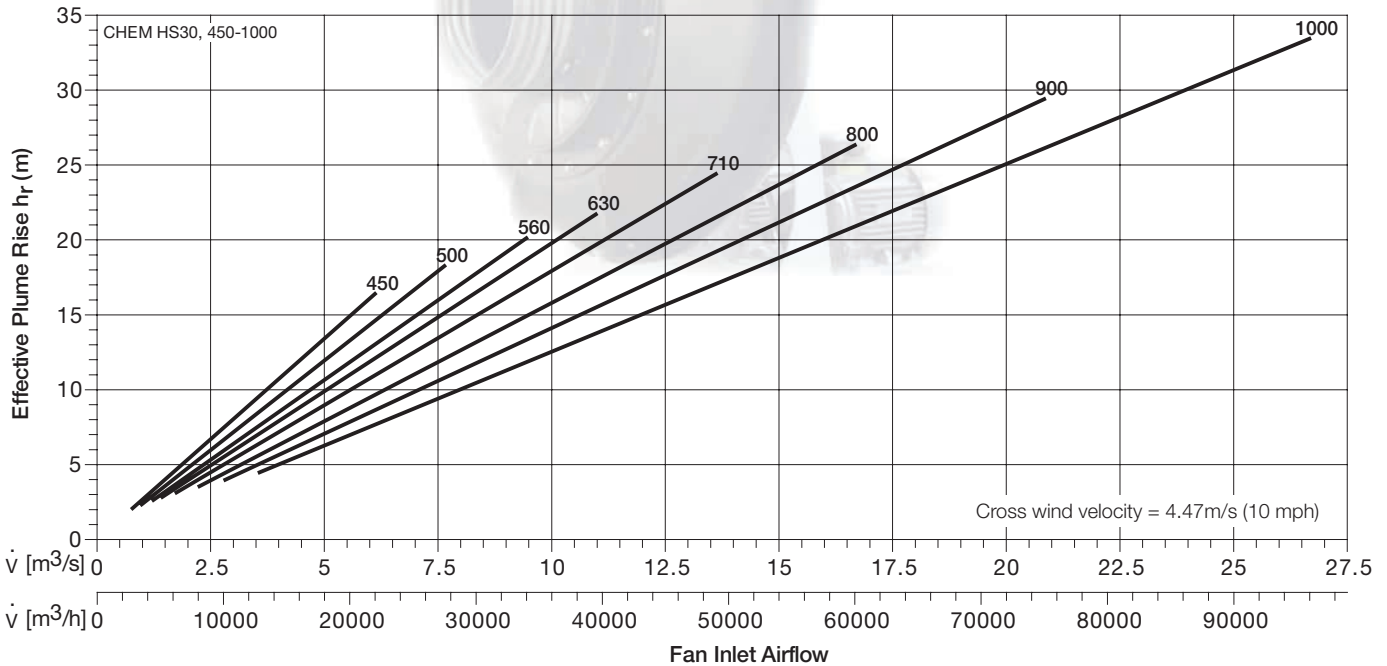

Effective Plume Rise h_r
 - HE30 Series, Fan Sizes CHEM 200 to 400

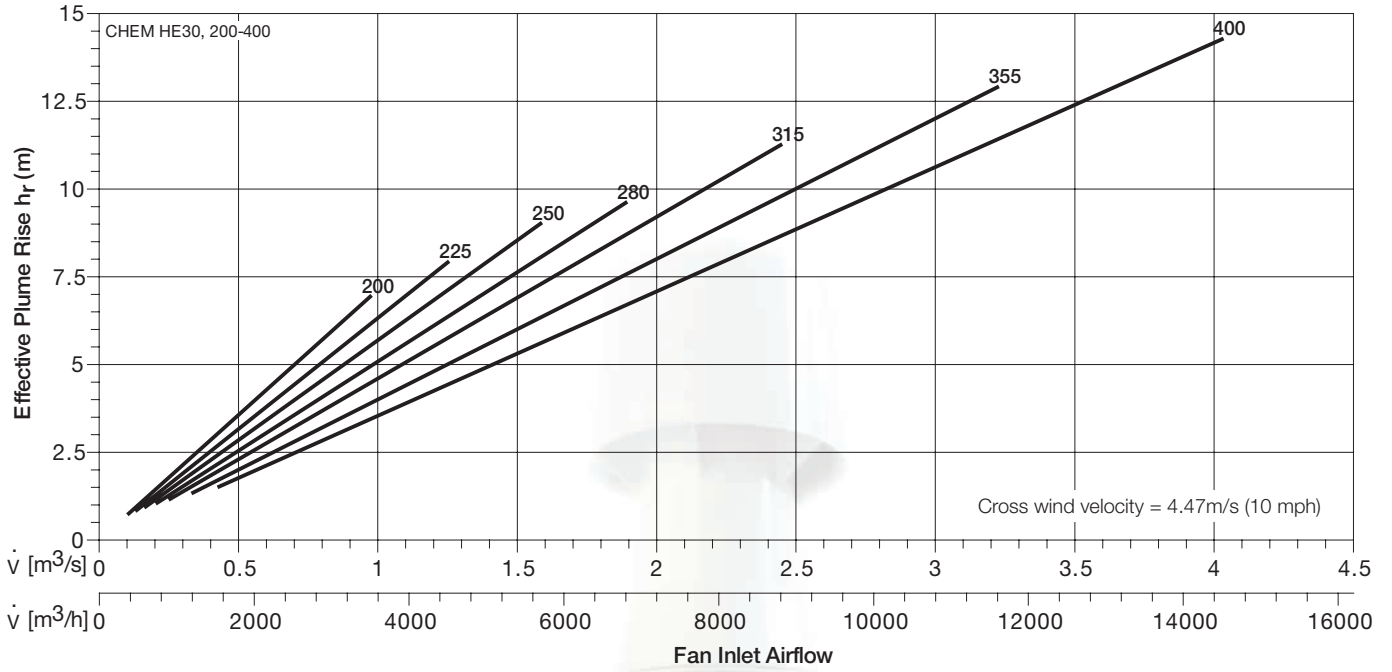

Effective Plume Rise h_r
 - HE30 Series, Fan Sizes CHEM 450 to 1000

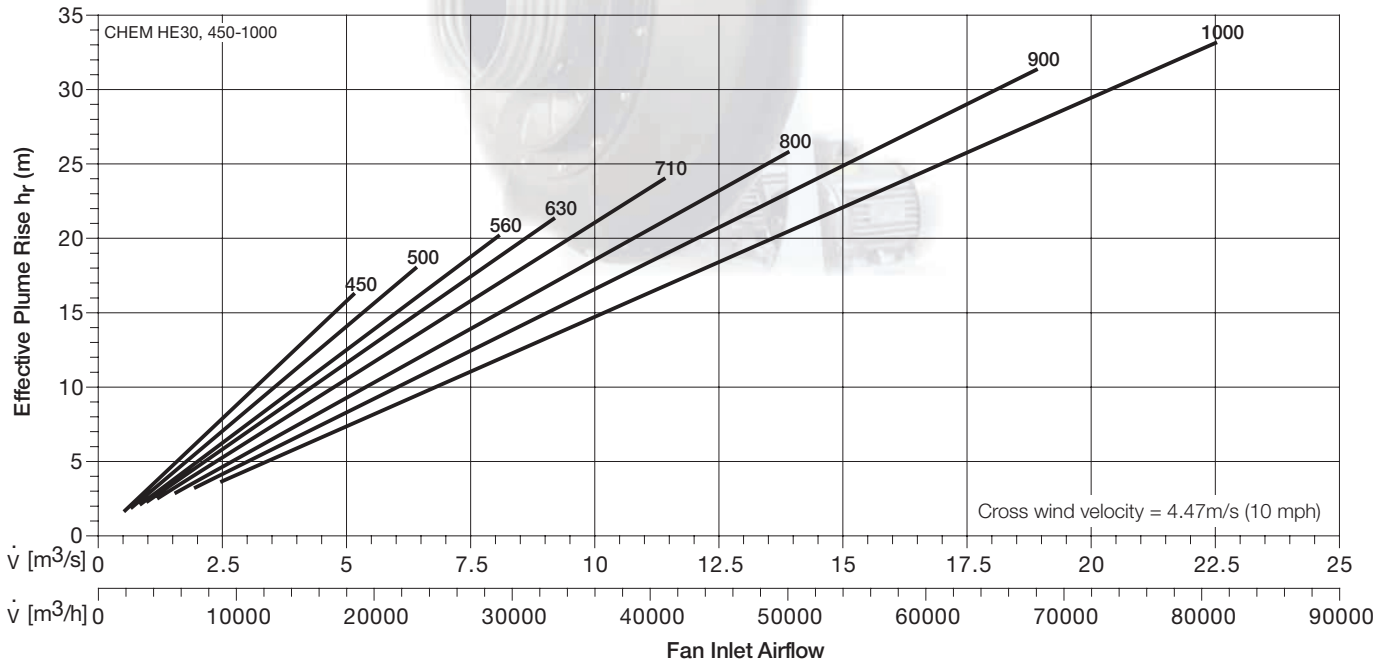

Effective Plume Rise h_r
 - HE50 Series, Fan Sizes CHEM 250 to 400

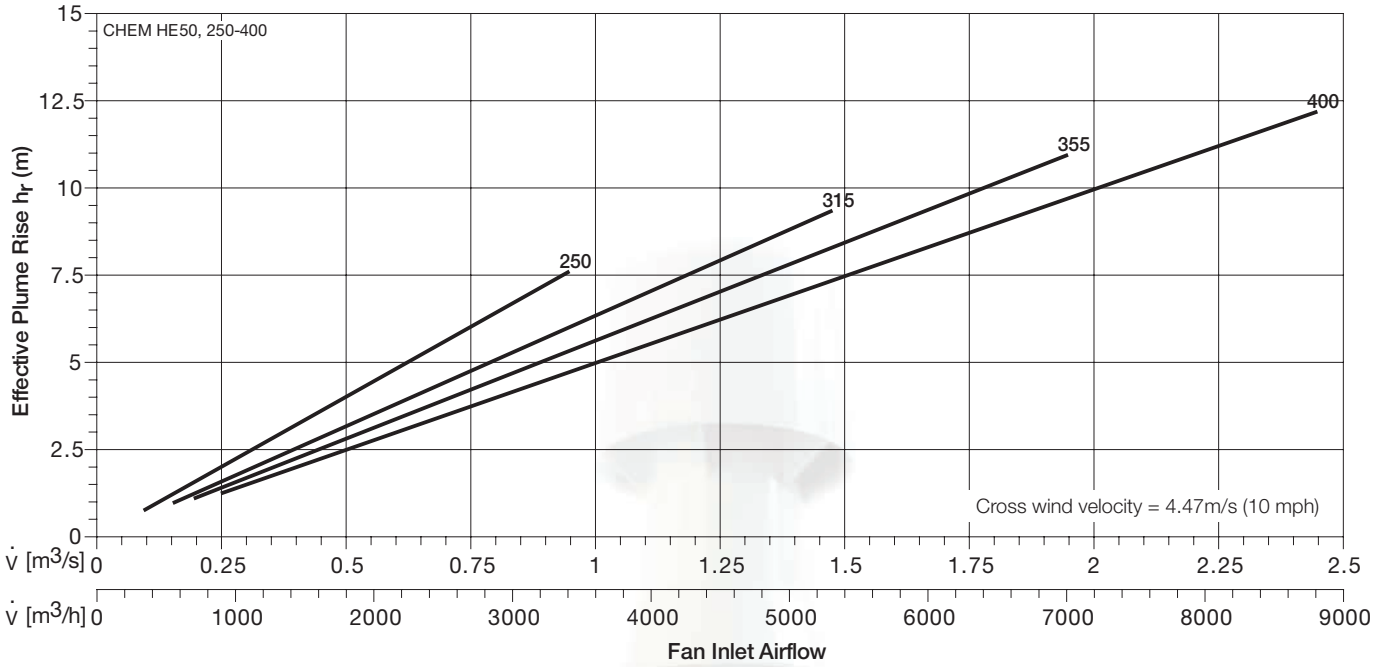

Effective Plume Rise h_r
 - HE50 Series, Fan Sizes CHEM 450 to 1000

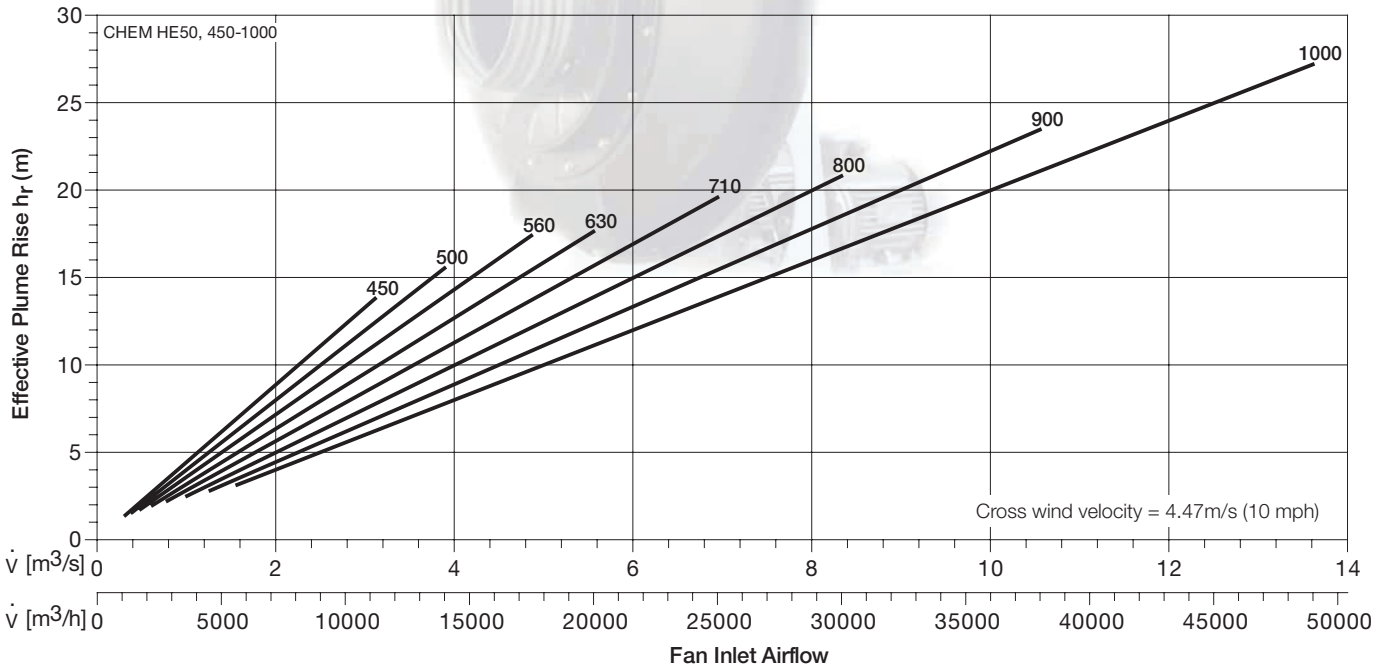

Effective Plume Rise h_r
 - HDE90 Series, Fan Sizes CHEM 250 to 400

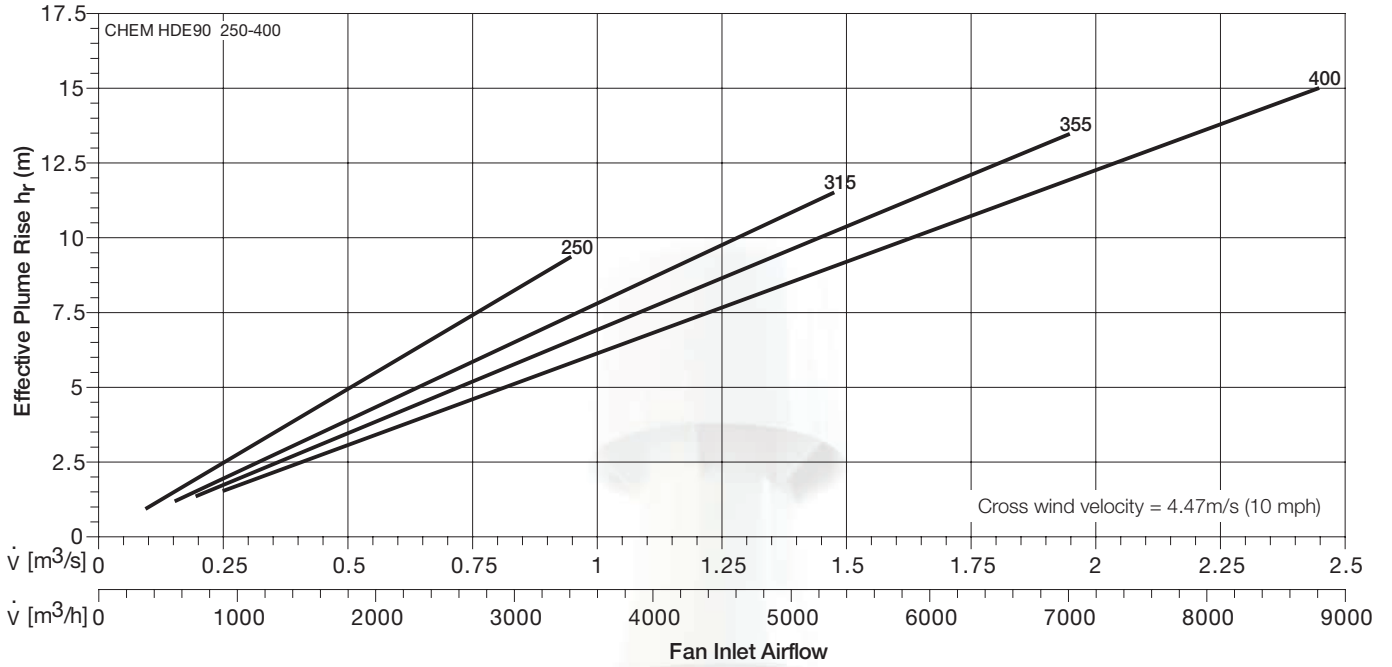

Effective Plume Rise h_r
 - HDE90 Series, Fan Sizes CHEM 450 to 1000

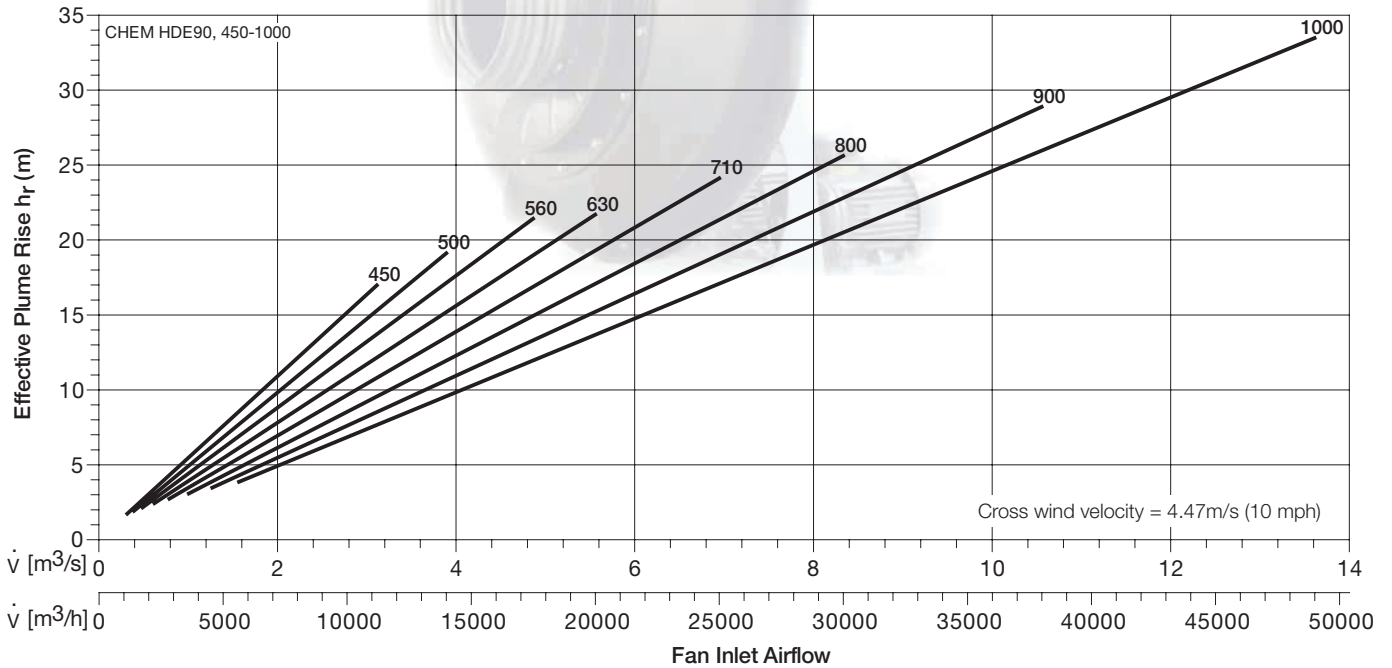

1FP Series

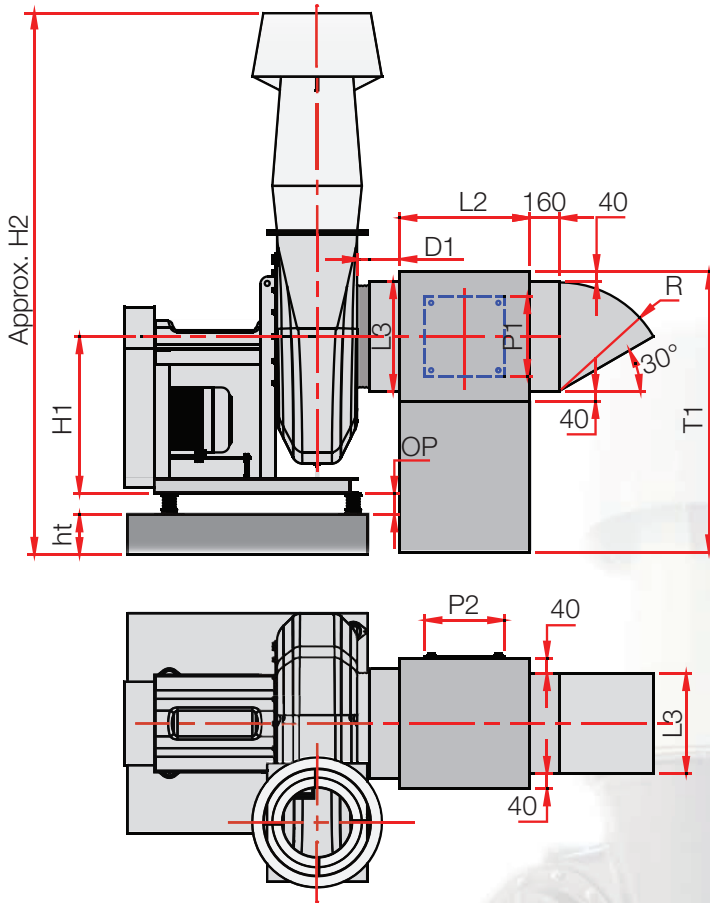

Damper

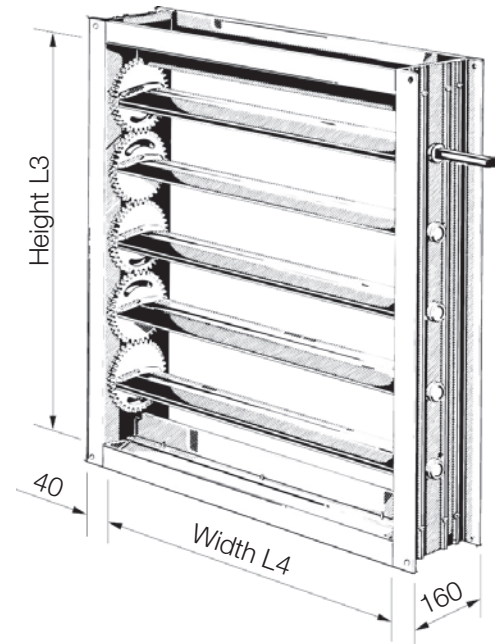

Various type of preferred plenum layout system

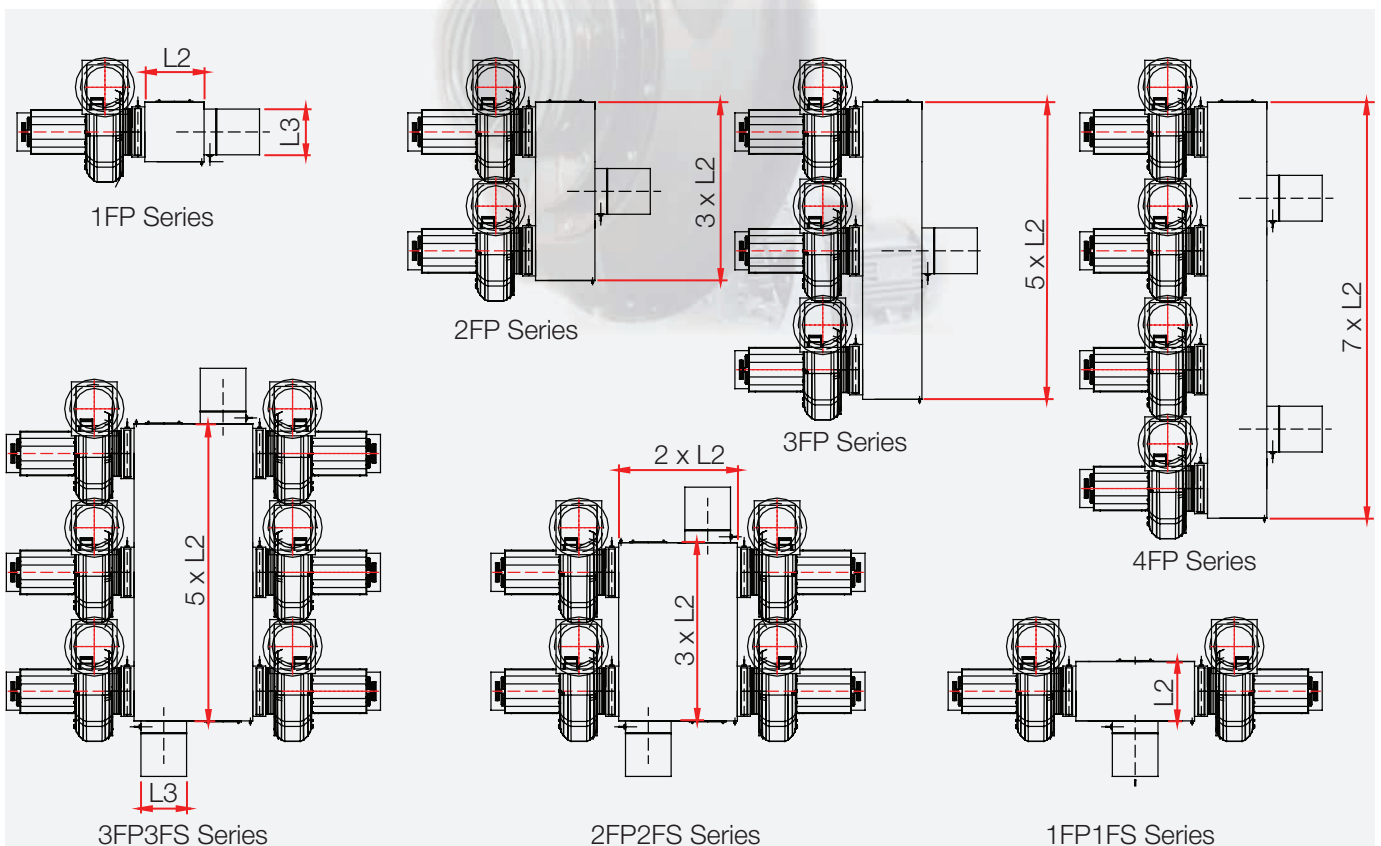

Plenum Layout System



Fan Model size	D1 [mm]	L2 [mm]	L3 [mm]	L4 [mm]	Area* [m2]	H1 [mm]	H2(HS30) [mm]	H2(HE30) [mm]
200	210	260	310	310	0,0822	529	1634	1616
225	210	310	310	310	0,0822	605	1860	1839
250	210	310	310	310	0,0822	605	1921	1898
280	210	410	410	460	0,1610	632	2076	2051
315	210	410	410	460	0,1610	632	2152	2124
355	235	410	410	460	0,1610	685	2374	2341
400	235	410	410	460	0,1610	685	2486	2449
450	235	460	510	460	0,2001	783	2703	2662
500	235	510	510	610	0,2654	870	2987	2940
560	235	610	610	610	0,3172	939	3279	3227
630	235	710	710	760	0,4598	1030	3611	3554
710	235	760	810	760	0,5244	1130	3980	3918
800	235	810	810	910	0,6279	1278	4457	4386
900	235	1010	1010	1060	0,9116	1375	4933	4854
1000	235	1060	1010	1060	0,9116	1550	5493	5404

Fan Model size	H2(HE50) [mm]	H2(HDE90) [mm]	ht [mm]	OP [mm]	P1 [mm]	P2 [mm]	R [mm]	T1 [mm]
200	1611	1787	200	90	290	290	310	964
225	1833	2028	200	90	290	290	310	1165
250	1891	2107	200	90	290	290	310	1165
280	2042	2284	200	90	400	390	460	1192
315	2123	2395	200	90	400	390	460	1192
355	2327	2634	200	90	400	390	460	1245
400	2434	2784	200	90	400	390	460	1245
450	2642	3035	200	90	400	400	460	1418
500	2905	3342	200	90	400	400	610	1505
560	3186	3675	200	90	400	400	610	1649
630	3572	4122	250	90	400	400	760	1790
710	3974	4594	250	114	400	400	760	1989
800	4434	5133	250	114	400	400	910	2212
900	4915	5701	300	114	400	400	1060	2359
1000	5446	6312	300	114	400	400	1060	2609

* Damper fully open area.

We reserve the right to alter measurements without notice in case of technical improvements

HS30 Series

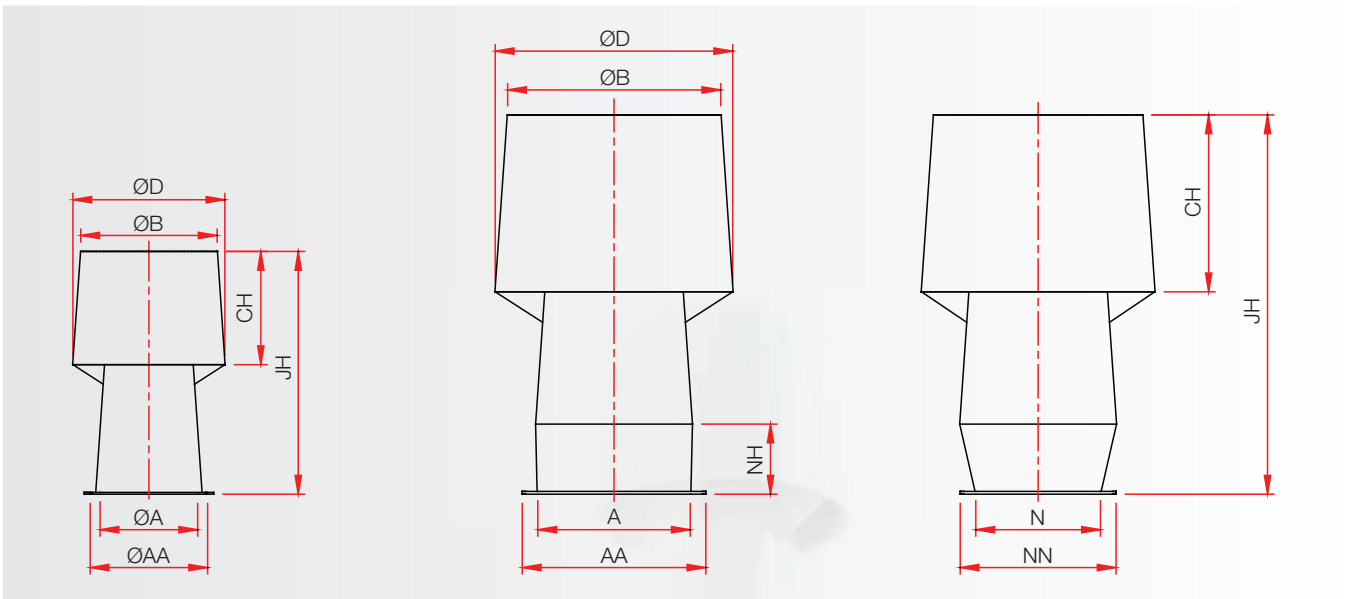

Fan Model	AA	NN	A	N	B	D	CH	NH	JH	Fan Height
Size	[mm]	[mm]	[mm]	[mm]	[mm]	[mm]	[mm]	[mm]	[mm]	[mm]
200	310	-	250	-	274	305	227	-	485	854
225	375	-	315	-	308	344	255	-	547	1018
250	375	-	315	-	343	382	284	-	608	1018
280	480	-	400	-	384	429	318	-	681	1146
315	480	-	400	-	427	476	354	-	757	1146
355	530	-	450	-	488	545	405	-	867	1152
400	530	387	440	290	551	615	457	181	979	1152
450	590	425	490	330	620	692	514	203	1102	1301
500	650	457	550	370	696	777	577	228	1237	1451
560	720	497	620	413	781	871	647	256	1387	1595
630	810	539	710	419	841	939	698	276	1495	1770
710	940	577	830	435	927	1034	769	304	1647	1960
800	1065	638	935	499	1054	1176	874	345	1872	2200
900	1176	715	1034	566	1180	1317	979	387	2097	2420
1000	1302	777	1160	638	1327	1481	1101	435	2358	2700

HE30 Series

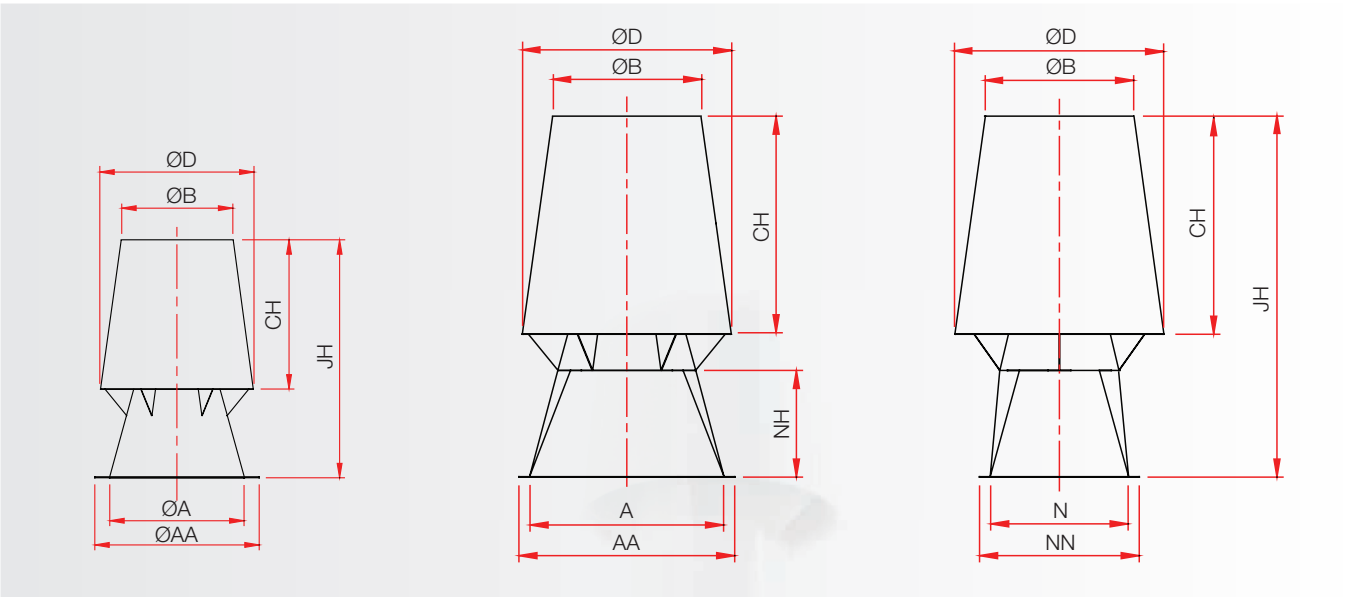

Fan Model	AA	NN	A	N	B	D	CH	NH	JH	Fan Height
Size	[mm]	[mm]	[mm]	[mm]	[mm]	[mm]	[mm]	[mm]	[mm]	[mm]
200	310	-	250	-	214	259	191	-	467	854
225	375	-	315	-	241	291	215	-	526	1018
250	375	-	315	-	268	324	239	-	585	1018
280	480	-	400	-	300	363	268	-	656	1146
315	480	-	400	-	334	404	297	-	729	1146
355	530	-	450	-	382	461	341	-	834	1152
400	530	387	440	290	431	521	385	181	942	1152
450	590	425	490	330	486	586	433	204	1061	1301
500	650	457	550	370	545	658	486	229	1190	1451
560	720	497	620	413	611	738	545	257	1335	1595
630	810	539	710	419	659	795	588	277	1438	1770
710	940	577	830	435	725	876	648	305	1585	1960
800	1065	638	935	499	825	996	736	347	1801	2200
900	1176	715	1034	566	924	1115	824	388	2018	2420
1000	1302	777	1160	638	1039	1254	927	437	2269	2700

HE50 Series

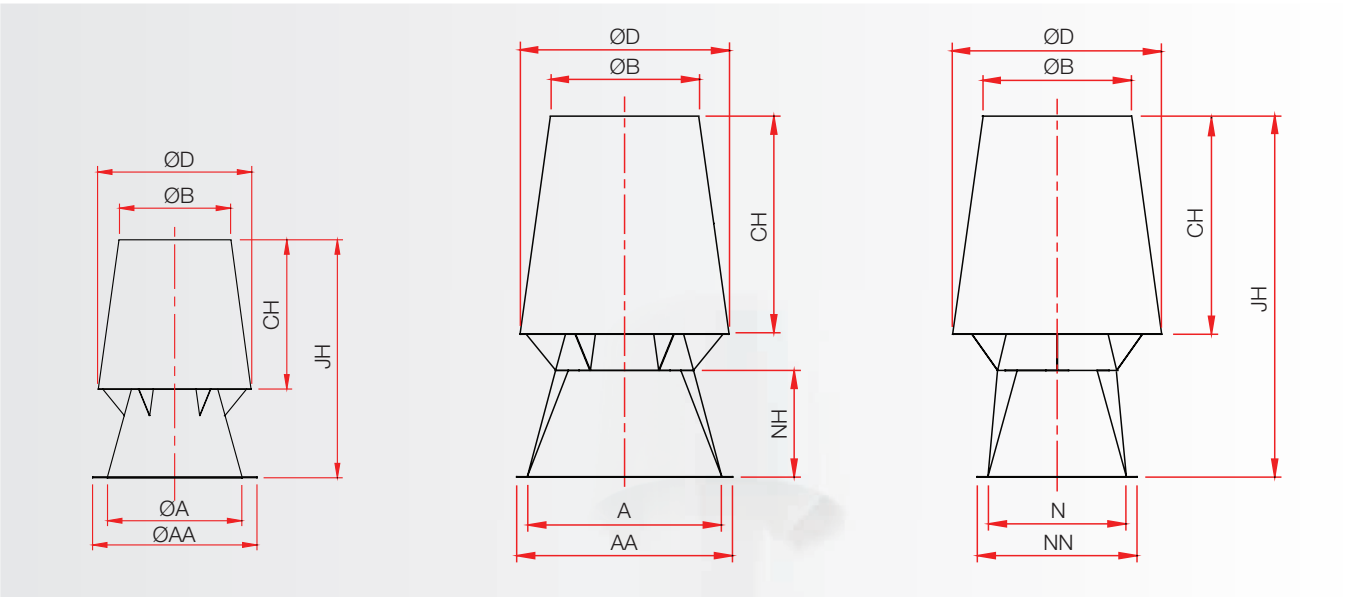

Fan Model	AA	NN	A	N	B	D	CH	NH	JH	Fan Height
Size	[mm]	[mm]	[mm]	[mm]	[mm]	[mm]	[mm]	[mm]	[mm]	[mm]
250	375	-	315	-	223	283	257	-	578	1018
315	480	-	400	-	281	356	323	-	728	1146
355	530	-	450	-	317	401	364	-	820	1152
400	530	387	440	290	358	453	412	181	927	1152
450	590	425	490	330	402	509	462	203	1041	1301
500	650	457	550	370	446	565	513	226	1155	1451
560	720	497	620	413	500	633	575	253	1294	1595
630	810	539	710	419	563	712	647	285	1456	1770
710	940	577	830	435	634	803	729	321	1641	1960
800	1065	638	935	499	715	905	821	361	1849	2200
900	1176	715	1034	566	804	1017	924	406	2079	2420
1000	1302	777	1160	638	893	1130	1026	452	2311	2700

HDE90 Series

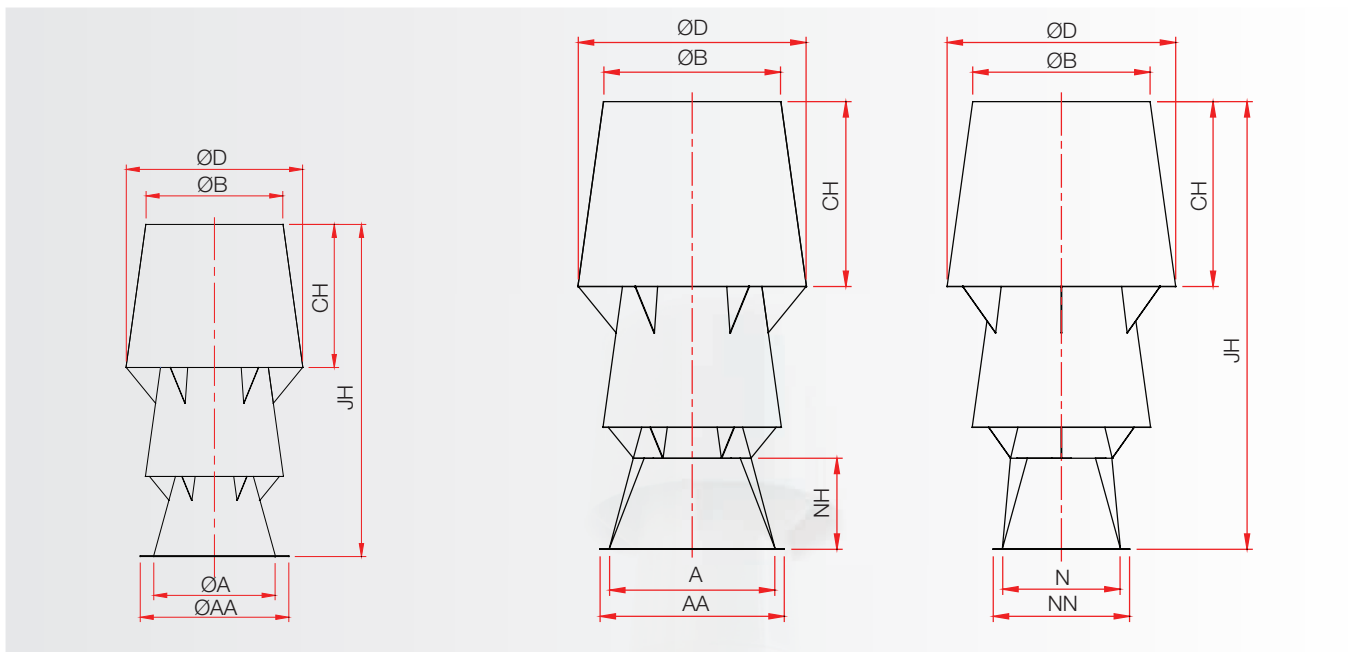

Fan Model	AA	NN	A	N	B	D	CH	NH	JH	Fan Height
Size	[mm]	[mm]	[mm]	[mm]	[mm]	[mm]	[mm]	[mm]	[mm]	[mm]
250	375	-	315	-	281	362	294	-	794	1018
315	480	-	400	-	354	457	370	-	1000	1146
355	530	-	450	-	399	515	417	-	1127	1152
400	530	387	440	290	451	581	471	181	1277	1152
450	590	425	490	330	506	653	529	203	1434	1301
500	650	457	550	370	562	725	588	226	1592	1451
560	720	497	620	413	629	812	658	253	1783	1595
630	810	539	710	419	708	913	740	284	2006	1770
710	940	577	830	435	798	1029	834	321	2261	1960
800	1065	638	935	499	900	1160	941	361	2548	2200
900	1176	715	1034	566	1011	1305	1058	406	2865	2420
1000	1302	777	1160	638	1124	1450	1175	451	3177	2700

Sales Network

Deutschland

Wolter GmbH.
Maschinen-und Apparatebau KG.
DE-76316 Malsch
T +49 (0) 72 04 / 92 01 0
F +49 (0) 72 04 / 92 01 11
info@wolter.eu

Europe

Denmark:

L.ØLAND VENTILATION A/S
DK-2605 Brøndby
T +45 (0) 70 / 20 19 11
salg@airforce.dk

Netherlands:

DE WIT Ventilatoren BV
NL-3821 CG Amersfoort
T +31 (0) 33 / 76 00 240
info@dewitventilatoren.nl

Sweden:

Nordisk Ventilator AB
SE-142 50 Skogås
T +46 (0) 8 / 72 70 250
se@nordiskventilator.se

Switzerland:

Anson AG Zürich
CH-8055 Zürich
T +41 (0) 44 / 46 11 111
F +41 (0) 44 / 46 13 111
info@anson.ch

OZ Tech SA

CH-1122 Romanel-sur-Morges
T +41 (0) 76 / 41 11 572
info@oztech.ch

United Kingdom:

Wolter (UK) Ltd.
GB-Leicestershire LE65 1AL
T +44 (0) 15 30 / 41 24 73
info@wolteruk.com

Middle East

UAE, Saudi Arabia, Qatar, Lebanon:

Please contact Wolter head office

Wolter GmbH.

Maschinen-und Apparatebau KG.
DE-76316 Malsch
T +49 (0) 72 04 / 92 01 0
F +49 (0) 72 04 / 92 01 11
info@wolter.eu

Asia

China:

Guangdong Wolter Chemco Ventilation Ltd.
Boluo, Huizhou, Guangdong

Dongguan Wolter Chemco Ventilation Ltd.

Shipai, Dongguan, Guangdong
T +86 (0) 769 / 8655 7298
F +86 (0) 769 / 8655 7278
info@wolter.com.hk

Taizhou Wolter Ventilation Co. Ltd.

Hengjie, Luqiao District,
Taizhou, Zhejiang
T +86 (0) 576 / 26 22 666 (26 52 888)
F +86 (0) 576 / 26 56 830

China - Hong Kong, Macau:

Wolter Asia Ltd
Kowloon, Hong Kong
T +852 (0) 2456 0198
F +852 (0) 2456 0290
info@wolter.com.hk

China - Taiwan:

Waxlink International Co., Ltd.
8F-2 No.218 Roosevelt Rd.,
Sec.6, Taipei, Taiwan
T +886 (0) 2 / 8932 1196
F +886 (0) 2 / 8932 1197
waxlink@mail.waxlinktw.com

India:

Wolter Ventilators India Pvt. Ltd.
867 D, Block-A, Sushant Lok, Phase-I,
Gurgaon - 122009 (Haryana)
T +91 (0) 124 2577797, 4261001-3
sales@wolterindia.in

Korea:

Kaceco-Wolter
14-1, Dang-dong, Gunpo-shi,
Gyeonggi-do
T +(82) 0 31 / 4773 104
F +(82) 0 31 / 4773 132
wolter@kaceco.com
info@kaceco.com

Malaysia:

Vibrantech (M) Sdn Bhd.
47200 Petaling Jaya Selangor
T +603 (0) 7847 3500
F +603 (0) 7847 3380
sales@vibrantech-sb.com

Singapore:

Wolter Pte. Ltd.
SG-569738 Singapore
T +65 (0) 63 / 52 95 48
F +65 (0) 63 / 52 95 47
info@wolterfans.com.sg

Thailand:

Wolter Ventilation Co., Ltd.
Thamai Kratumban Samutsakorn
741 10 Thailand
T +66 (0) 84 555 2936
kongsakol@wolterfan.com

Australia

The Sydney Fan Company.
NSW 2147, Sydney, Australia
T +61 (0) 2 / 9624 4000
F +61 (0) 2 / 9624 4100
sales@thesydneyfancompany.com

Wolter GmbH Maschinen-und Apparatebau KG

Am Wasen 11
DE-76316 Malsch / Germany
T +49 (0) 72 04 / 92 01 0
F +49 (0) 72 04 / 92 01 11
www.wolter.eu
info@wolter.eu





Air in Motion

Reference: **R10.5**, March 2024 Printed in March 2024

Dongguan Wolter Chemco Ventilation Ltd.(Wolter Asia)

Shipai Town, Dongguan City, Guangdong, P. R China

Tel. (+86)769 86557298, Fax (+86)769 86557278

www.wolterfans.com

info@wolterfans.com

