



## Operation and Maintenance Manual

### Wolter Vehicle Exhaust Motorized Hose Reel (VHM) with (VE / VD) Exhaust Fan Unit





1	General safety notes .....	3
1.1	The operator's duty of care .....	3
1.2	Explanation of the safety symbols used .....	3
1.3	Basic safety measures .....	4
1.4	Particular kinds of hazards .....	4
2	Product description .....	5
2.1	General .....	5
2.2	User manual .....	5
2.3	User.....	6
2.4	Installation .....	5
2.5	Use.....	5
2.6	Operating the system .....	6
2.7	Service, maintenance and repairs .....	6
3	Product description .....	6
3.1	Stipulated usage .....	6
3.2	Service and technical support .....	6
3.3	3.3 Identification of the product .....	7
3.4	Reel (VHM) Technical data .....	7
3.4.1	VHM Dimensions.....	8
3.4.2	Weight of VHM unit without components.....	9
3.5	Motor electric data and lifting capacity.....	9
3.6	Exhaust Fan VE/VD Technical data .....	10
3.6.1	Fan type code.....	10
3.6.2	Technical data.....	10
3.6.3	Fan Dimensions.....	11
4	Transportation and Storage .....	13
4.1	Transportation .....	13
4.2	Storage .....	13
5	EC Declaration of Conformity .....	14
6	VHM motorize adjustment, installation and parts replacement .....	15
6.1	Setting of motorize coiling maximum operating and rest position .....	15
6.1.1	Detail on how to adjusting limit switches.....	15
6.1.2	VHM During Operation.....	15
6.2	Before operation .....	16
6.3	Assembly .....	16
6.4	Mounting Installation Height and dimensions .....	17
6.4.1	Mounting Installation .....	17
6.4.2	Reach and mounting height .....	18
6.5	Check the VHM terminal box wiring.....	18
6.6	Mounting options .....	18
6.6.1	Direct mount fan .....	18
6.7	Mechanical damper.....	19
6.8	Maintenance .....	19
6.8.1	Replacing the exhaust hose .....	19
6.8.2	Replacing bearings .....	21
6.8.2.1	To replacing the hose Bearing with Collar on the fan plate.....	21
7	Exhaust Fan VE / VD Installation .....	23
8	Fan Initial Start-up .....	23
8.1	Checks prior to initial start-up.....	23
8.2	Starting up the fan for the first time.....	24
8.3	Checks after initial start-up.....	24
9	Trouble Shooting .....	24
9.1	Fan Help with Malfunctions.....	24
9.2	Tabular overview of possible malfunctions and aids in eliminating those malfunctions.....	24
10	General Maintenance .....	25
10.1	VE / VD Servicing.....	25
10.2	Prior to all servicing work .....	25
10.3	Recommended periodic inspection intervals .....	26
10.4	Periodic inspection checks .....	26
10.5	VE / VD Maintenance Schedule MC001 .....	27
11	The Unit Pressure Loss Calculation .....	28
12	Electrical Wiring Diagram.....	29
13	Spare Parts .....	31

## Introduction

This publication is for use on standard VHM with VE/VD fan and all information are subjected to changes or amendment with or without notification.

It is the users responsibility to ensure this documents are most updated and it is only serve as a guideline for installation, use, maintenance and repair work.

Always consult the manufacturer, if necessary and thus the manufacturer cannot be held responsible for any damage resulting of this publication or either for any errors occurring in this publication. All rights reserved.

# 1 General safety notes

## 1.1 The operator's duty of care

The Wolter Vehicle Exhaust Motorized Hose Reel (VHM) with VE/VD fan term as "Unit" in this publication have been constructed and built whilst taking into account an analysis of the hazards involved, and after careful selection of the harmonised standards to be observed, as well as other further technical specifications. They thus correspond to the current level of technology and guarantee a high degree of safety. In operational practice, however, this level of safety can only then be attained if all required measures are taken. It is incumbent upon the operator's duty of care to plan these measures and to monitor their execution.

Users are required to familiarize themselves with installation and wiring instructions in addition to requirements of all applicable codes, laws and standards.

The examples and diagrams in this manual are included solely for illustrative purposes.

Because of the many variables and requirements associated with any particulate installation, Wolter cannot assume responsibility or liability for actual use based on the examples and diagrams.

No patent liability is assumed by Wolter with respect to use of information, circuits, equipment, or software that may be described in this manual. Throughout this manual, when necessary, notes may be used to make you aware of safety considerations.

Fume exhaust exposure levels should be checked upon installation and periodically thereafter to ensure that they fall within applicable regulations and exposure limit values.

In particular, the operator must ensure that

- › the Unit is only used as stipulated on "Product Description"
- › the Unit is only operated in a faultless and functional condition and that safety fittings, especially, are regularly examined with respect to their functionality
- › the operating instructions are always maintained in a readable condition and are available at the Unit's location of deployment in their entirety
- › only sufficiently qualified and authorised personnel operate, maintain and repair the machine
- › these members of personnel are familiar with the operating instructions and especially the safety notes contained therein
- › no safety and warning signs fitted to the fan are removed, and that they are kept in a readable condition.
- › the Unit's surrounding is kept clean to avoid items from being sucked into the fan and/or blocking the air flow

## 1.2 Explanation of the safety symbols used

The following symbols are used in these operating instructions. These symbols are, above all, intended to draw the reader's attention to the text contained in the adjacent safety note.













Warning

This symbol indicates that dangers exist which are hazardous to life and health.



Warning

Identifies information about practices or circumstances that can cause an explosion in a hazardous environment, which may lead to personal injury, death, property damage, or economic loss.



	Warning	Procedures which, if not carried out with the necessary caution, may damage the product or cause serious personal injury.
	Warning	Fire hazard! Important warning to prevent fire.
	Attention	Identifies information about practices or circumstances that can cause an explosion in a hazardous environment, which may lead to personal injury, death, property damage, or economic loss.
	Attention	A remark with additional information for the user. A remark brings possible problems to the user's attention.
	Caution	Procedures, if not carried out with the necessary caution, could damage the product, the workshop or the environment.
	Mortal danger	Electrical hazard. Serious - and also fatal - injury can result if these notes are disregarded.
	Shock hazard	Labels may be on outside or inside of fans and control boxes used in the exhaust removal system, to alert people that dangerous voltage may be present.
	ARC flash hazard	Labels may be on outside or inside of the equipment, for example control box, to alert people to potential Arc Flash. Arc Flash will cause severe injury or death. Wear proper Personal Protection Equipment (PPE). Follow ALL regulatory requirements for safe work practices and for Personal Protective Equipment (PPE)
	Tip	Suggestions and recommendations to simplify carrying out tasks and actions.
	Note	Indicates user tips and other useful advice.

### 1.3 Basic safety measures

Wolter VHM and VE/VD fans are, at the moment of delivery, manufactured to the current level of technology. Extensive materials, function and quality checks assure them of a high level of usefulness and long service life. Nevertheless, these machines can be dangerous if they are improperly used by untrained personnel or are used in a non-stipulated manner.

 Read these operating instructions carefully before putting the unit into operation!

Only operate the unit in its enclosed state with properly fitted built-in protective screens.

-  - Assembly, electrical connection and maintenance may only be carried out by trained craftsmen!
-  - Only operate the unit in the manner stipulated and within the specified output limits (see rating plate) and with approved conveyed media!

### 1.4 Particular kinds of hazards

The VE/VD centrifugal fans in this respect, particular hazards are caused by the impeller rotor and through the flow of air, which can, at times, be considerable. For this reason the following points are to be observed:

- ▶ Never reach into the rotor when it is rotating. Do not try to use your hand as a brake for the rotor during maintenance work.
- ▶ Loose clothing or light parts can be sucked in by the draught of air. That is why you should always wear tight-fitting clothing during maintenance work and whilst near the fan inlet.

- › Larger items can obstruct or totally ruin the rotor and other parts of the fan. For this reason, the protective screens and built-in guide vanes on the fan inlet and outlet must be fitted at all times during operation.
- › The rotor must not be put into operation while it is removed from the housing

## 2 Safety

### 2.1 General

The manufacturer does not accept any liability for damage to the product or personal injury caused by ignoring the safety instructions in this manual, or by negligence during installation, use, maintenance, and repair of the product mentioned on the cover of this document and any corresponding accessories. Specific working conditions or used accessories may require additional safety instructions. Immediately contact your supplier if you detect a potential danger when using the product.



Note

The user of the product is always fully responsible for observing the local safety instructions and regulations

### 2.2 User manual

- › Everyone working on or with the product must be familiar with the contents of this manual and must strictly observe the instructions therein. The management should instruct the personnel in accordance with the manual and observe all instructions and directions given.
- › Always keep the manual with the Unit.

### 2.3 User

The use of this product is exclusively reserved to authorized, trained and qualified users. Temporary personnel and personnel in training can only use the product under supervision and responsibility of skilled engineers.

### 2.4 Installation

- › Inspect the unit and check it for damage. Verify the functioning of the safety features.
- › Never install the Unit in front of entrances and exits which must be used for emergency services.
- › Make sure that the workshop, in the vicinity of the product, contains sufficient approved fire extinguishers

### 2.5 Use

- › Check the working environment. Do not allow unauthorized persons to enter the working environment.
- › Use common sense. Stay alert and keep your attention to your work. Do not use the Unit when you are under the influence of drugs, alcohol or medicine.
- › Make sure the room is always sufficiently ventilated; this applies especially to confined spaces

## 2.6 Operating the system

- With the VHM, an operator can motorize the hose downward to a require position, As Fig.1. At the same time, the fan will switches "ON" automatically;

When the hose (37) is no longer needed, the operator can motorize to recoil the hose and should guides the hose back to its rest position. Just before the hose reaches its rest position, the fan will switches "OFF" automatically.



Fig.1: 1 = motorize the hose down, Fan switches "ON"

Fig.2: 2 = guide the hose back, Fan switches "OFF"

## 2.7 Service, maintenance and repairs

- This manual contains instructions for replacing the hose (37), and replacing Drive bearing (09) and Hose Bearing (16) with collar. (Refer to Section 6.8 for more details replacement).

# 3 Product description

## 3.1 Stipulated usage

Our Vehicle Exhaust Unit's have been specially developed for use in modern garages, underground car washing bays, light or heavy duty vehicle workshop, warehouses etc., with high ceilings to removes pollution gas and fumes aiming to improve airflow and overall comfort. The hose can withstand high temperature, can be easily rewind when not in use and to prevents the extraction hoses from entangling thus increase works safety and tidiness. The unit can be ceiling or wall mounted and best used in a stationed workshop with very limited space.



Fig.3

The VHM motorize coiling module (21) can be either operated with a single phase (34kg lifting capacity) or a three phase version (50kg lifting capacity).

An operator can motorize the hose downward to a convenient position; when no longer needed. After used, the operator can motorize to recoils and guides the hose in a controlled manner to its rest position.

The VHM includes ceiling or wall mounting feet as a standard. The VHM can also be used in central systems or with direct mounted. It is designed to operate with hose diameters of 100, 125, 150 and 200 mm. (except the 200 mm hose reel) can be fitted with a direct mount fan.

Note: Direct Mount fans are NOT available for the 200 mm hose version!

## 3.2 Service and Technical support

### Unit description

The maximum hose length the Unit is dependent on these factors:

- the specific version of VHM reel ordered;
- the type and size of the hose;
- the exhaust fan;
- the nozzle



Fig.4



Fig.5

### 3.3 Identification of the product

The identification plate contains:

- › the fan model (eg. VD 400-58) & reel model (VHM 1250-200)
- › the Art No.

### 3.4 Reel (VHM) Technical data

VHM come with motorize coiling module (21) is located outside of the reel for easy replacement, if needed. The maximum lifting capacity is 34kg with a single phase version (21E) and 50kg with a three phase version (21D). Standard VHM Model such as VHM 850, VHM 1050 and VHM 1250 are available for application.

Below are options, such as hoses (37) type and lengths, nozzle (43), mechanical dampers, motor output, etc

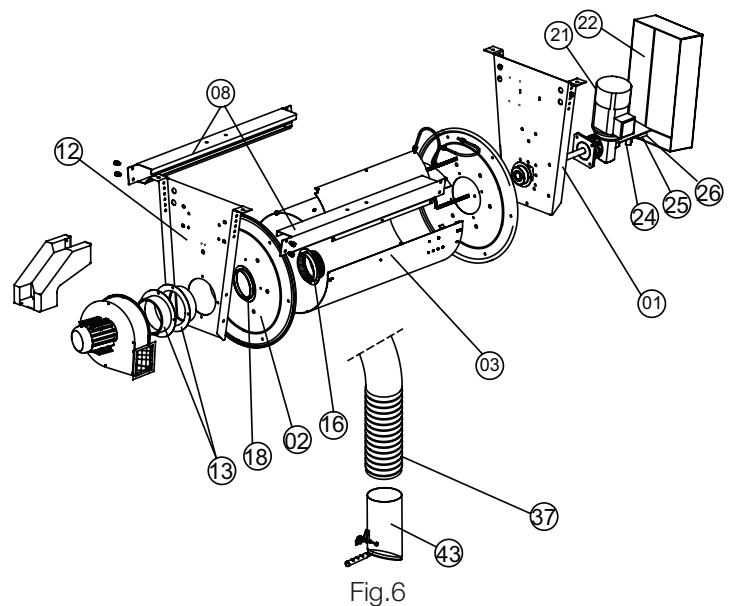

Fig.6

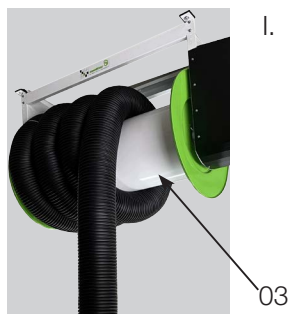

Fig.7

- I. Reel Casing (03) provides tidy and convenient storage location for the hose (37):
  - The casing on which the hose rolls are zinc-plated steel sheet, powder coated in White;
  - Reel side plates (02) are of steel sheet completely spanned and powder-coated in Green;

- II. The Base Frame (08) provides robust and rigid support are of steel sheet and powder-coated in White.
- III. The Fan Plate (12) and Drive Plate (01) are of steel sheet and powder-coated in White.



Fig.8

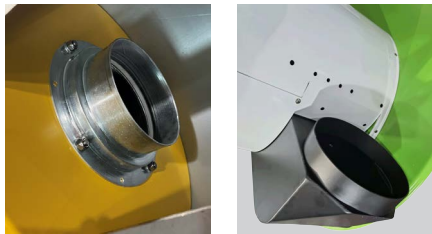

Fig.9a

Fig.9b

IV. Collars of size 160mm (13, 16 & 18) Fig.9a or 200 mm (Fig.9b) or 200mm diameter for connecting to fan or central exhaust system are available



Fig.10a

V. Hose (37) - Upon request, 100mm, 125mm, 150mm and 200mm diameter of standard (37) or higher temperature are available Fig.10a. Optional Nozzle (43) are available Fig.10b.



Fig.10b

VI. Motorized Coiling Module (21) with cover (22) - Electrical box for wiring connection and control of equipment; includes a self-locking bevel gear drive motor, limit switches (24, 25 & 26) and thermal overload protection. A standard, wall-mounted control box for up/down operation is provided. Optional automatic on/off switches, hanging pendant and other wireless controller and sensors are available upon request.

As per user request, the VHM motorize can come with either a single phase motor (21E) for 34 kg max. lifting capacity or a three phase motor (21D) with max. 50kg lifting capacity.



Fig.11

### 3.4.1 VHM Dimensions

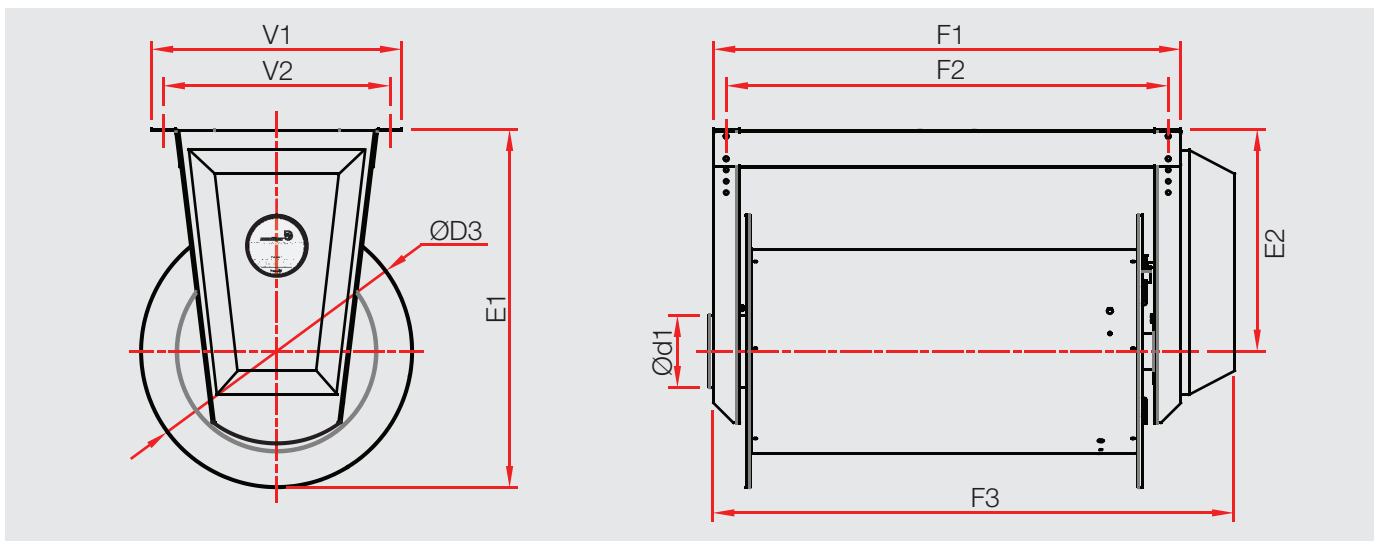

Table 1

Model	d1	D3	E1	E2	F1	F2	F3	V1	V2
-	[mm]	[mm]	[mm]	[mm]	[mm]	[mm]	[mm]	[mm]	[mm]
VHM 850	160	600	789	489	1030	974	1313	552	500
VHM 1050	160	600	789	489	1230	1174	1513	552	500
VHM 1050-200	200	760	977	597	1230	1174	1513	578	525
VHM 1250-200	200	760	977	597	1430	1374	1713	578	525

Note: Subject to change without prior notice.

### 3.4.2 Weight of VHM unit without components

Table 2

Product Name	Hose Diameter	Max. hose length on reel	■ (w/o components)
[-]	[mm]	[m]	[kg]
VHM 850-100	100	10	72
VHM 850-125	125	11	72
VHM 850-150	150	10	72
VHM 1050-100	100	12.5	75
VHM 1050-125	125	12.5	75
VHM 1050-150	150	12.5	75
VHM 1050-200	200	10	79
VHM 1250-200	200	12.5	82

Note: Subject to change without prior notice.

#### Example of total hose and component weight

Hose length 12.5 meter are required. The table below demonstrates the total weight of hose and MN 150 nozzle. The total weight will be as below:

Table 3

Product Name	■ (Calculation)	■ (Total)
EH 150 Hose	1.04 kg/m	13.0 kg
MN 150 Nozzle	3.50 kg	3.50 kg

Total weight of hose and components: 16.50 kg  
 VHM single phase Max lifting capacity: 34 kg

Standard VHM Model such as VHM 850, VHM 1050 and VHM 1250 are available for application. The nozzle type, the length and diameter of the hose required will determine the VHM model to be ordered.

Note: As an alternative to VHM fan can be connected to a ductwork system. Model VE / VD 300-13, 300-18, 300-21 can be directly mounted to the hose reel.

Hose, fan(s), starters and other collars must be ordered separately with 150 mm or 200mm diameter hose for connection with a central exhaust system. Hose and nozzle must be ordered separately.

### 3.5 Motor Electric Data and Lifting Capacity

Single phase motor:

Voltage: 230 V  
 Frequency: 50 Hz  
 Output Power: 0.55 kW  
 Current: 3.61 A  
 Speed: 920 RPM  
 Capacity: 70 μF  
 Lifting Capacity: 34 kg

Three phases motor:

Voltage: 400 V  
 Frequency: 50 Hz  
 Output Power: 0.55 kW  
 Current: 1.8 A  
 Speed: 930 RPM  
 Lifting Capacity: 50 kg



Tip

Refer to the available product data sheet for detailed product specifications.

### 3.6 Exhaust Fan VE/VD Technical data

#### 3.6.1 Fan Type Code

**V D 320 - 30**

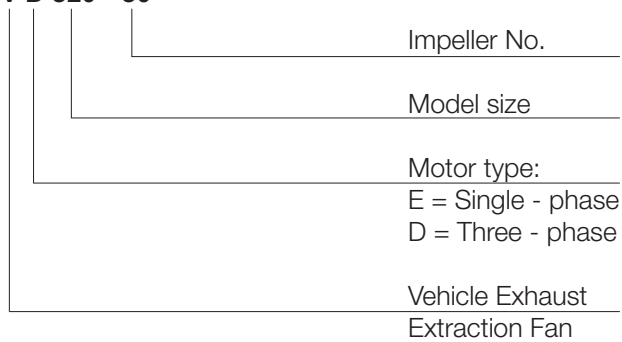

Fig.12

#### 3.6.2 Technical Data

Table 4

Model Size	Speed [1/min]	Power [kW]	Current [A]	Capacitor [µf]	Max. Airflow [m³/h]	Sound Power Level [dB(A)]	Weight [KG]
------------	---------------	------------	-------------	----------------	---------------------	---------------------------	-------------

(Power Supply: Single Phase 50Hz 220V)

VE 300-13	2880	0,37	2,73	12	1050	63	13,5
VE 300-18	2880	0,55	3,88	16	1220	64	14,2
VE 300-21	2880	0,75	5,15	30	1560	66	21,0
VE 320-30	2880	1,1	7,02	35	2600	68	31,2
VE 380-47	2880	2,2	13,7	40	3720	76	50,0

(Power Supply: Three Phases 50Hz 400V)

VD 300-13	2880	0,37	0,94	-	1050	63	20,2
VD 300-18	2880	0,55	1,33	-	1220	64	20,9
VD 300-21	2880	0,75	1,81	-	1560	66	27,8
VD 320-30	2880	1,1	2,52	-	2600	68	37,2
VD 380-47	2880	2,2	4,69	-	3720	76	58,5
VD 400-58	2880	3,0	6,00	-	5660	76	82,5
VD 450-67	2880	4,0	7,72	-	7200	77	97,0
VD 500-76	1450	1,1	2,74	-	4000	63	98,0
VD 500-76	2880	5,5	10,5	-	8600	78	113

Note: 1, The volume airflow indicated above is measured in AMCA 210 chamber;

2, The sound level are measured from the fan body when ducts are connected on both inlet and outlet side.

3, Subject to change without prior notice.

### 3.6.3 Fan Dimensions

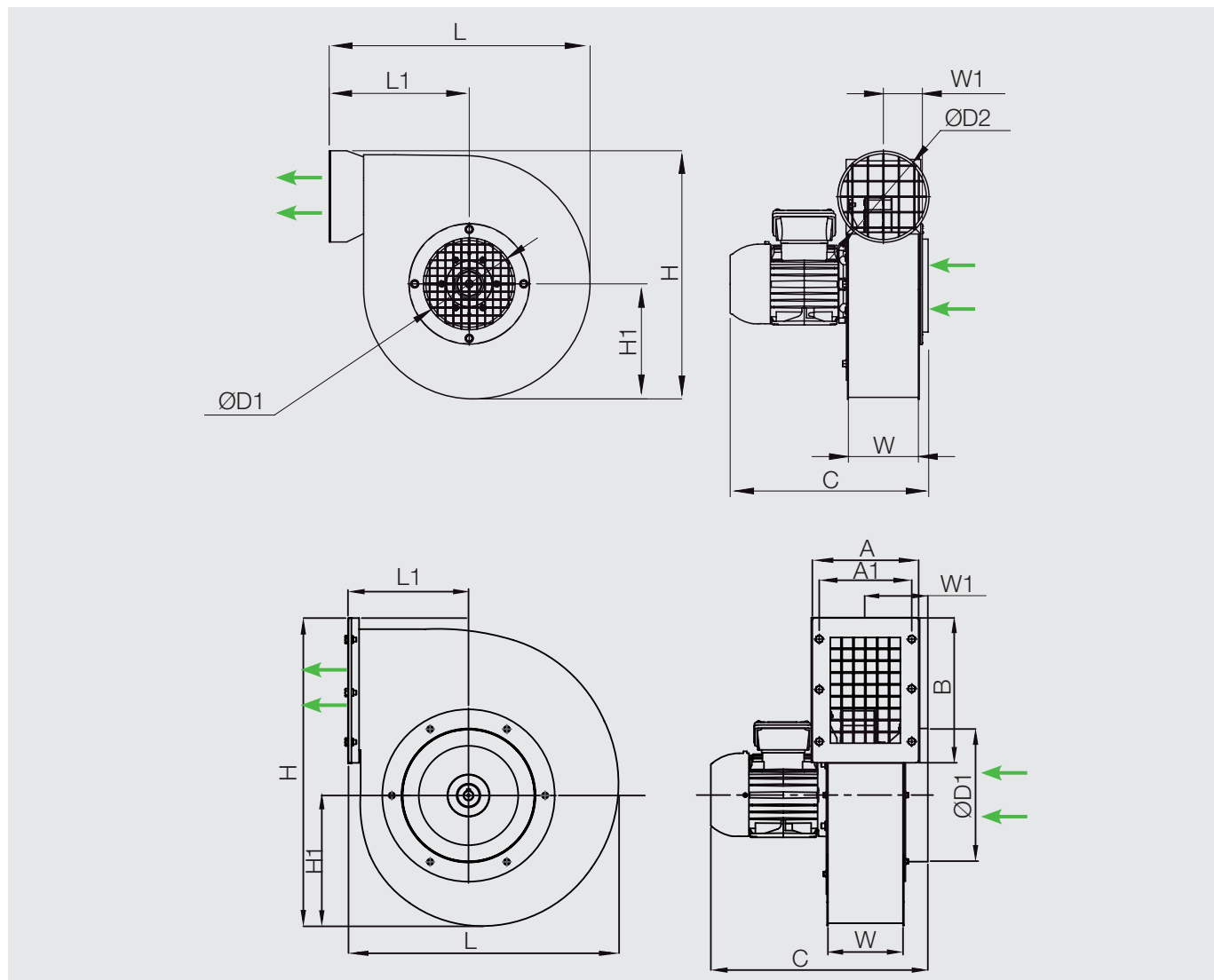

Table 5

Model	A	A1	B	C	D1	D2	H	H1	L	L1	W	W1
-	[mm]	[mm]	[mm]	[mm]	[mm]	[mm]	[mm]	[mm]	[mm]	[mm]	[mm]	[mm]
VE / VD 300-13	-	-	-	330	160	159	433	201	455	244	122	68
VE / VD 300-18	-	-	-	330	160	159	433	201	455	244	122	68
VE / VD 300-21	-	-	-	353	160	159	433	201	455	244	122	68
VE / VD 320-30	250	230	278	479	203	-	597	267	577	278	196	126

Note: Subject to change without prior notice.

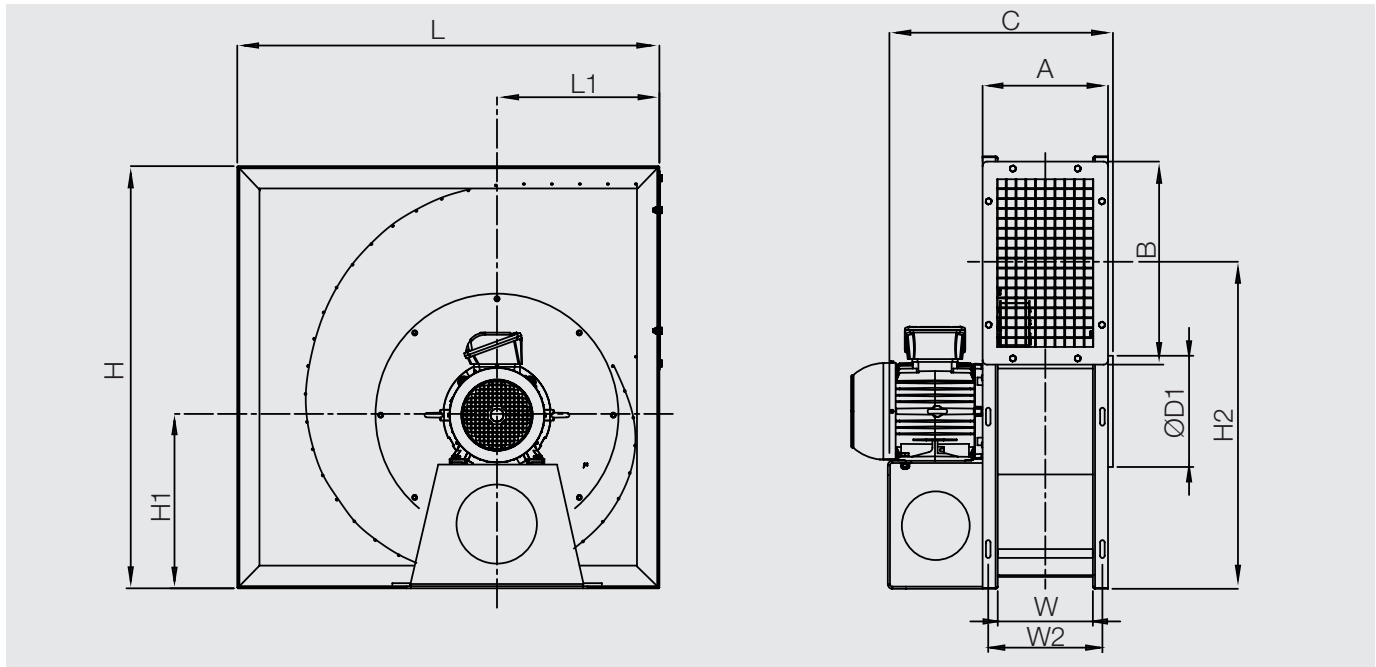

Table 6

Model	A	B	C	D1	D2	H	H1	H2	L	L1	W	W2
-	[mm]	[mm]	[mm]	[mm]	[mm]	[mm]	[mm]	[mm]	[mm]	[mm]	[mm]	[mm]
VE / VD 380-47	250	348	479	245	-	750	321	576	750	315	196	240
VD 400-58	270	380	532	400	-	783	342	602	783	339	200	244
VD 450-67	280	420	570	450	-	882	372	669	882	358	210	254
VD 500-76	290	460	606	500	-	980	402	741	980	377	220	264

Note: Subject to change without prior notice.



**Note**

The fan impeller are statically and dynamically balanced at the factory, and manufacture is subject to the strictest intermediate and end checks and is certified in accordance with DIN/EN/ISO 9001.

**Conditions of use**

The air should correspond to tender specifications, as the corresponding components are determined for this. If these are not listed in more detail, then the following applies:

The fans are suitable for the conveyance of

- › air containing car exhaust emissions
- › air which has little dust and grease content
- › gases and vapours which are non-explosive and only slightly aggressive in nature

**Conditions of fitting**

Please contact the manufacturer for more information in intend for other application or otherwise shall be considered as improper usage!



**Warning**

In particular, we especially draw your attention to the following points. Non-compliance can either result in considerable material damage or personal injury, or that the demanded fan output values are not attained.



**Warning**

The fan may not be operated without the necessary safety fittings. For this reason, protective screens on the fan inlet must be fitted at all times during operation in order to prevent access to rotating parts.

In order to avoid any damage to the Unit, specially to the rotor blades, you must prevent the possibility of loose parts being sucked in by the fan or of other items being able to find their way into the fan.

The fitting notes regarding inlet and outlet flow conditions are to be observed.

## 4 Transportation and Storage

### 4.1 Transportation

Wolter VHM and fans Units are packed at the factory to suit the respectively agreed mode of transportation. Transport the Unit in its original packaging.

- › Only use suitable means of transport, such as pallet trucks or fork-lift trucks.
- › If the fan is to be transported by hand, ensure that supporting and carrying loads are kept within reasonable limits for the personnel involved.



The following special hazards must be taken into account when transporting the equipment:

- › The transportation packaging does not prevent damage to the equipment through improper transportation.
- › The fans must not be dropped or thrown.
- › Sharp, protruding edges can lead to injury through cuts.



- › Suspended loads can fall, which then constitutes a fatal hazard - stand well clear of suspended loads!
- › Parts which have been stacked too high can collapse.
- › If load-carrying devices other than those specified here are used, then this can lead to serious damage to the machine.
- › A risk of fire exists due to the easily flammable nature of the packaging materials
- › Do not use naked flames and do not smoke!
- › Read the chapter, "General Safety Notes".

### 4.2 Storage

- › Store the Unit in a dry, weather-protected location in its original packaging or protect it from the effects of dirt and the weather until final assembly.
- › Cover open pallets with tarpaulin sheets and protect the Unit from the effects of dirt and contaminants (e.g. swart, stones, wire etc.)
- › Avoid extremes of cold and heat.
- › Avoid lengthy storage periods (a maximum of two years is recommended).
- › The nozzle, U-Guide (42), M&I manual and other accessories, etc are placed on a box together with hose (37).
- › The motorized coiling system is fitted with limit switches to control the up/down positions and fan start signal.

## 5 EC Declaration of Conformity

In accordance with Appendix II A of the EC Machinery Directive (89/392/EWG)

**The manufacturer: Dongguan Wolter Chemco Ventilation Ltd.**

No.69, Miao Bian Wang Road, Shipai, Dongguan, Guangdong, PRC China

**hereby declares that the machine described in the following EC Directives:**

Vehicle Exhaust Hose Reel: VHM 850-100; VHM 850-125; VHM 850-150; VHM 1050-100; VHS 1050-125;  
VHM 1050-150; VHM 1050-200; VHM 1250-200.

With Exhaust Fan: VE / VD 300-13; VE / VD 300-18; VE / VD 300-21; VE / VD 320-30; VE / VD 380-47;  
VE / VD 400-58; VD 500-76.

meets the health and safety requirements of the following EC Directives:

**In accordance with Machinery Directive (98/37/EG), Appendix II A in accordance with the Low Voltage Directive (73/23/EWG )**

**Harmonized standards applied:**

**EN 60204-1:** Safety of machinery; electrical equipment of machines, Part 1: General requirements

**EN 292:** Safety of machinery; basic concepts, general principles for design

**EN 294:** Safety of machinery , Safety distances for the prevention of injuries within danger zones

**IEC 60335-2-80:** Household and similar electrical appliances - Safety - Part 2-80: Particular requirements for fans

**IEC 60335-1:2010 + AMD1:2013 + AMD2:2016 CSV Consolidated version:**

Household and similar electrical appliances - Safety - Part 1: General requirements

**Note:**

The compliance with EN 294 refers to the fitted contact safety device only, as it is part of the extent of delivery. The total compliance with EN 294 is the system manufacturer's or the contractor's responsibility.

**EN 60034-1 / IEC 34-1**

Rotating electrical machines: Part 1: Rating and performance

**EN 60034-5**

Rotating electrical machines - Part 5: Degrees of protection provided by the integral design of rotating electrical machines (IP code) - Classification

**EN 60085-5**

Electrical Insulation. Thermal evaluation and designation

**EN ISO 12100:2010**

Safety of machinery - General principles for design - Risk assessment and risk reduction

**AMCA 300: Reverberant Room Method for Sound Testing of Fans**

The ascertaining of the sound power level follows the reverberant room measurement method according to AMCA 300

**AMCA 210: Laboratory Methods of Testing Fans for Certified Aerodynamic Performance rating**

The performance curves provided in this catalogue were measured according to AMCA 210 in a test chamber.

If the machine is a single component of a complete equipment/machinery, the conformity of this equipment/machinery with the EC Machinery Directives has to be ensured before the initial operation.

Date: 25.02.2016



**Nicholas Ang**  
Vice President

## 6 VHM Motorize Adjustment, Installation and Parts Replacement

### 6.1 Setting of motorize coiling maximum operating and rest position

- ▶ Adjusting the set-screw (A2, B2 and C2) to click on limit switch (A1, B1 and C1)
- ▶ After removing the Motorized Coiling Module (MCM) cover, the installer may set the start/stop hose to operating and rest position by adjusting the set-screws (A2 and B2) to touch the on/off limit switches (A1 & B1).
- ▶ Set the fan start signal by adjusting the set-screws (C2) to touch the on/off limit switch (C1)

#### 6.1.1 Detail on how to adjusting limit switches

- ▶ Uncoil the hose to its required position (A 1/4 turn must be remain at the reel casing).
- ▶ Remove the motorized coiling module casing cover, then loosen the set screw (A2) and adjust the set screw (A2) until you hear the limit switch (A1) was touches. (These will set the hose at max operating location)
- ▶ Recoil back the hose to the preferred rest position then loosen the set screw (B2) and adjust the set screw (B2) until you hear the limit switch (B1) was touches. (These will set the hose at max. preferred resting position)
- ▶ Then adjust the limit switch (C1) with the set screw (C2) to set the fan to switch "OFF" at required rest position.

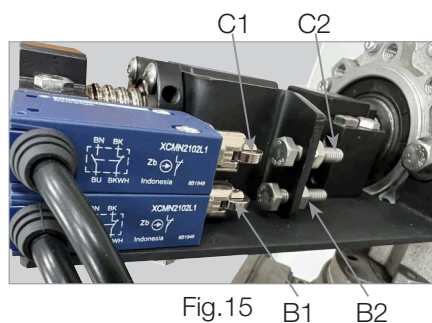

Fig.15

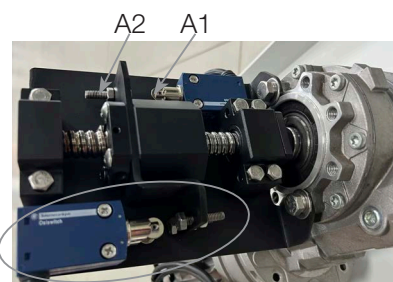

Fig.16



#### Note

While Uncoiling for operation: The limit switch (B1) should switches "ON" the hose uncoiling first, then the fan was switches "ON" by limit switch (C1);  
While recoiling to rest position: The C1 limit switch should switch "OFF" the fan first, then the coiling switches was allowing to switches "OFF" (B1) at rest position

#### 6.1.2 VHM During Operation

- ▶ To operate the VHM hose reel, when uncoiling the hose to its required operating position, limit switch B1 will "untouched" release and "ON" to release down the hose.  
At the same time, limit switch C1 will also "untouched" to switch "ON" the fan for operation.
- ▶ When the hose was release at any required operating location, the fan will continue to be "ON". However, when the hose was uncoiling to its max operation position set limit. Limit switch (A1) will was touched and A1 limit switch will be set at "OFF", but the fan will continue to be at "ON" operation.
- ▶ While during operation, the user wishes to recoil the hose to another shorter location, the hose can still be recoiled but the fan will still continue to be at "ON" operation. The limit switch A1 allow the hose to recoil to any shorter location.
- ▶ When the user wishes to finish the operation, just before the hose was recoil to its final rest position, the fan will switch "OFF" automatically when the limit switch touches C1, following by the hose touching limit switch B1, then hose will "STOP" operation.  
If these work well, close the motorized coiling module casing back in position.



#### Warning

Set-screw must be tightened well after setting the hose position and fan on/off, reel vibrations may loosen these nuts. Servicing should check every 6 months.

## 6.2 Before Operation

The hose reel operated by one of the below up/down control systems:

- › Control Box with Up / Down push buttons
- › Optional: hanging pendant
- › Optional: wireless controller

Either any of the above control, the button must be pressed to uncoil or roll up the hose until the required rest position (as per set limit on A & B) is reached.

Optional hanging pendant and wireless controller listed above must be ordered separately.



### Warning

When recoiling the hose, users are recommended to guide the hose in a safely controlled manner to its rest or intended position. When operating the hose reel, be careful not to damage to the hose, any other property or cause injury to people must always be avoided.

## 6.3 Assembly

These tools are needed to install units:

- › Power Drill / Electric Screw gun.
- › General hand tools / wrenches
- › Screw drivers

Complete steps to install the VHM hose reel as shown in diagram:



Fig.13

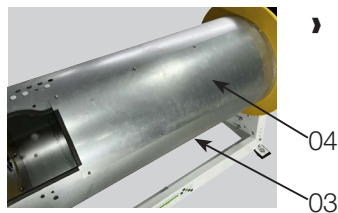

- › Dismantle casing cover (04) Fig. 13 (VHM 1050-200 version not required)

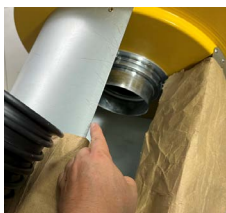

Fig.14

14

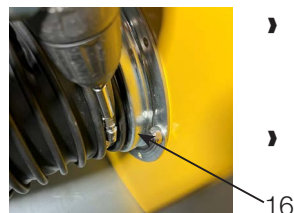

Fig.15

- › Carefully place the hose (37) inside the casing and recommend to place cardboard Fig.14 on casing edge to avoid cut on hose.
- › Mount the hose (37) to the hose bearing with collar(16) inside the reel casing (03) with a hose clip (40) Fig.15.



Fig.16

- › Place the protection strip (14) Fig.16 at the opening of the casing where the hose protrudes.



Fig.17

- › Bend hose (37) into a natural soft curve and fasten it using U clamp (19) provided Fig.17.



Fig.18

- › Re-mount the casing cover (04) Fig.18.

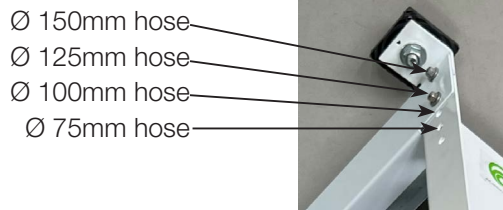

Fig.19

- › The base frame holes are pre-set for the correct diameter hose, as shown in Fig.19. The base frame provides multiple holes for spring operated hose reels, and these do not need to be adjusted for VHM.



Fig.20

Start the motorized coiling module, recoil the hose and set the limit switches for up and down as per .6.1.1 and 6.1.2.

## 6.4 Mounting Installation Height and dimensions

### 6.4.1 Mounting Installation

Use the reach and mounting height chart for specific hose lengths and maximum hose reach.



#### Attention

When horizontally mounting a reel that contains either a 150 mm or 200 mm hose, it is recommended that you attach the hose so that it rotates around the "front" of the unit (away from the column or wall), as shown in Fig. 21.

This will prevent the hose (37) from scraping the horizontal base frame (08), or colliding with any items attached to the column or wall below the VHM.

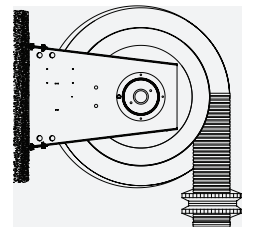

Fig.21

Unit mounting on wall



#### Caution

When the reel is mounted to a rigid structure like an iron beam or concrete Fig.22, then use the dimensions provided. However, when the reel is being mounted to porous or otherwise doubtful materials like hollow brick, threaded rod, lightweight concrete, plaster etc., please consult the manufacturer.

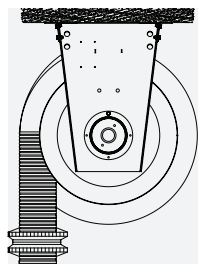

Fig.22

Unit hang on ceiling

"1/4 turn" of the hose



Fig.23

#### Warning

After installation, operators must be made aware that a "quarter turn" of the hose should always remain on the reel casing, as shown in Fig. 23.

If the hose is pulled down completely, and the entire hose is removed from the unit, the recoil mechanism will be locked, and the hose reel will no longer retract the hose. If this occurs, the casing must be turned manually for the recoil mechanism to release.

6.4.2 Reach and mounting height

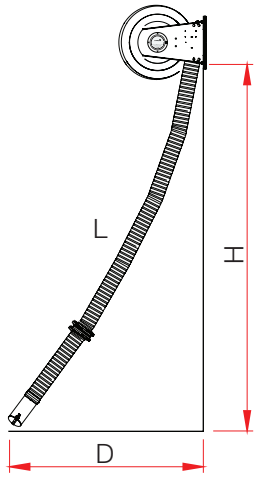

Fig.24

Mounting Height	Hose Length	Max. Reach	Hose Length	Max. Reach
H	L	D	L	D
[m]	[m]	[m]	[m]	[m]
3	7.5	6.2	-	-
3.5	7.5	5.9	10	8.5
4	7.5	5.5	10	8.3
4.5	7.5	5.2	10	8.0
5	7.5	4.7	10	7.7
5.5	-	-	10	7.4

Table 8

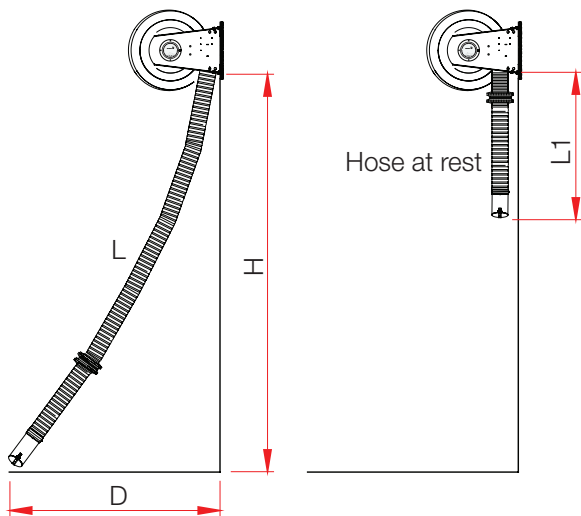

Fig.25

Mounting Height	Hose Length	Max. Reach	At Rest
H	L	D	L1
[m]	[m]	[m]	[m]
5	12.5	10.6	0
5.5		10.3	
6		10.0	
6.5		9.7	
7		9.4	
5.5	15	12.9	2.5
6		12.6	
6.5		12.3	
7		12.1	
7.5		11.8	

Table 9

Note: Remember to consider the hose reel's lifting capacity when mounting at higher elevations, factoring in the Total weight of the hose (37) and nozzle (43).

6.5 Check the VHM terminal box wiring

Based on the model selected, the factory motor name plate wiring will be configured for 230V or 400V, as shown in below Fig.26

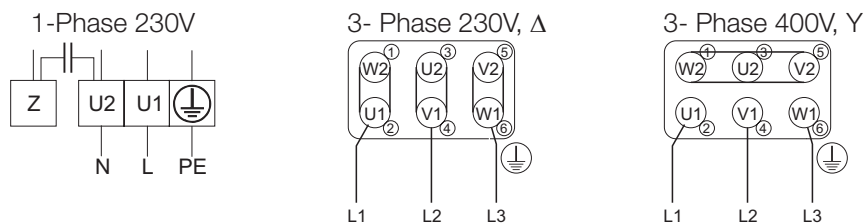

Fig.26

6.6 Mounting options

6.6.1 Direct mount fan

The VHM includes ceiling or wall mounting attachment foot. All VHM versions except for 1050-200 and 1250-200 can

be fitted directly with a fan. All version can be used on a central exhaust system.



**Caution**

Make sure the supporting structure can handle the VFM dynamic load associated with the hose reel. Always consult a structural engineer prior to installation, to ensure compliance with all local codes.



Fig.27



Fig.28

- › First, mount the fan with the reel upside down on the floor (Fan are available in LG270 or RD 270) and then mount the complete reel to its intended position.

Example of a LG 270 fan (view from motor side, fan outlet at anti clock wise) Fig.27.

- › With hose reel securely installed in position or placed on a level working surface, insert the pedestal support (45) with the bolts and hand tighten the nuts on to fan plate(12) Fig.28.



Fig.29

- › Place the fan with motor (44) on the pedestal support (45); Align fan bolt holes with the holes in the Pedestal support (45). Insert bolts and tighten slightly;

Slide the pedestal support (45) up and down parallel to the fan plate (12) center to align with outlet collar (13); Tighten bolts to ensure the unit is properly secured Fig.29.



Fig.30

- › Place HT flexible connector (39) between fan inlet spigot plate (47) and outlet collar (13);

Tighten the HT flexible connectors (39) with hose clip (40) Fig.30;

- › Stiffen the mounting by bolting 2 pieces of angle brackets (46) on fan inlet spigot plate (47) to fan plate (12)

Note: Direct mounted fans are of either VE (1P) or VD (3P) model such as 300-13, 300-18, 300-21 or 320-30.

## 6.7 Mechanical damper

VHM are designed suitable for use with a mechanical damper installed on the duct portion of the hose reel especially with multiple hose reels.

The built-in mechanical damper allows airflow to work on hose reel being used to save energy costs.

The damper will automatically open when the hose is lowered and fan is switch "ON", and closes when the fan was switch "OFF" while the hose was coiled at rest position.



**Note**

Only one mechanical damper should be in use for one hose reel. Optional EC motor with electronic control units, actuator damper and other sensors are available upon request.

## 6.8 Maintenance

### 6.8.1 Replacing the exhaust hose (37)

- › Uncoil hose (37) completely and lock reel in its most extended (Pre-tension) position Fig.31;



Fig.31



Fig.32

- › Dismantle protection strip (14), casing cover (04), and U-clamp (19) Fig.32.



Fig.33

- › Loosen hose clip (40) on the connecting the hose bearing with collar (16) and remove the old hose Fig.33.



Fig.34

- › Attach new hose (37), the surface of the hose should be protected with card board to avoid in case of any cut damages Fig.34.



Fig.35

- › Attach new hose (37), the surface of the hose should be protected with card board to avoid in case of any cut damages Fig.35.



Fig.36

- › Carefully bend the hose (37) into a natural soft curve and fasten it using U-clamp (19) Fig.36.

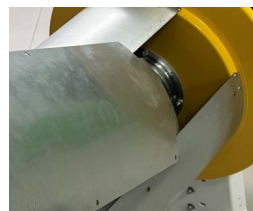

Fig.37

- › Re-install the casing cover (04) Fig.37.



Fig.38

- › Re-mount the standard nozzle (43) with clamp Fig.38 and the reel is now ready for use.

## 6.8.2 Replacing bearings

### 6.8.2.1 To replace the hose bearing with collar (16) on the fan plate (12)

Noted on the hose stopper (20) position. Take off the stopper (20) and nozzle (43) with adapter (if any)



Fig.39



Fig.40

- › To safely perform this operation, it is recommended to remove the fan with 8 bolts and nuts and the flexible connector Fig.39 from the VHM Fan Plate (12) structure and stand it on the floor Fig.40.



Fig.41



Fig.42

- › Uncoil hose (37) completely Fig.41. Dismantle protection strip (14), casing cover (04), and U-clamp (19) Fig.742.



Fig.43

- › Loosen hose clip (40) on the connecting the hose bearing with collar and remove the hose Fig.43. Ensure the hose (37) is prevent damage and are place in a safe area to prevent any damage or dents.



Fig.44



Fig.45

- › Place a support under the reel casing (03) and loosen the 4 bolts holding the fan plate (12) and the base frame (08) Fig.44.
- › Once the bolts have been removed, carefully remove the fan plate (12), and ensure the reel casing (03) is safely and securely supported to prevent damage Fig.45.

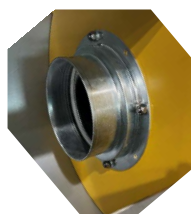

Fig.46

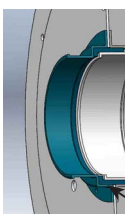

Fig.47

- › Once the fan plate (12) has been removed, remove the 4 or 8 bolts and nuts that securing the damaged drive hose bearing with collar (16) from the fan plate (12) Fig.46. Replace with a complete new hose bearing with collar (16) Fig.47.



Fig.48

- › Assembly back the fan plate (12), and ensure the reel casing (03) is safely and securely supported. Bolts on the fan plate with 4 bolts and nuts together with the base frame (08) in position Fig.48.



Fig.49

- › Hose (37) surface are recommended to be safely protected by cardboard.  
Carefully mount the hose (37)\_on to the hose bearing with collar (16) in position Fig.49.



Fig.50

- › Re-install the protection strip (14) at the opening of the casing where the hose protrudes Fig.50.



Fig.51

- › Bend the hose (37) into a natural soft curve and re-fasten it using U-clamp (19) Fig.51.



Fig.52

- › Re-mount the casing cover (04) Fig.52.



Fig.53

- › Re-mount the Standard Nozzle (43) with clamp Fig. 53.

## 7 Exhaust Fan VE / VD Installation

When lifting the fan into its position on the ceiling during installation, secure it from falling down until it is securely installed.



**Attention:** Make the electrical connection in accordance with the technical connection conditions and the relevant regulations!

The motor is equipped with thermal contacts, they must be properly checked if trip-off frequently. Failure to do so will void the warranty.



**Before checking the direction of rotation:**

Remove foreign bodies from the fan area.

Protective screen must be fitted.

Check the direction of travel in accordance with the arrow on the housing by switching on and off very quickly.

## 8 Fan Initial Start-up

The following points are to be observed in order to avoid damage to the machinery or life-threatening injury during initial start -up:

- › Only qualified personnel may carry out the machine's initial start-up and this must take place in compliance with the safety notes.
- › Prior to initial start -up, check that all tools and foreign bodies have been removed from the machine.
- › Activate all safety devices and Emergency Stop switches prior to initial start -up.
- › Check the motor's direction of travel prior to initial start-up.
- › Read the chapter, "General Safety Notes ".

### 8.1 Checks prior to initial start-up

Proceed with the fan's initial start-up in the following sequence:

- › Check that the mechanical assembly has been carried out properly
- › Remove foreign bodies located in the suction and outflow areas and in the fan space



Check that the electrical installation has been completed in accordance with regulations

Does the mains voltage match the motor voltage specified on the rating plate?

Is the switchgear used suitable for the motor both with respect to the switching functions to be carried out and also to the switching conditions and switched output of the motor?

Is the motor protection system set correctly with regard to the motor's nominal current? The setting must be carried out in accordance with the corresponding details contained on the motor output plate.

Has the motor been connected correctly in accordance with the wiring diagram?

The connection schematic supplied must be exactly applies for the connection of the motor.



Accident prevention

Inlet protective screen must be fitted on the inlet of the fan to meet safety regulations.

## 8.2 Starting up the fan for the first time

Only put the fan into operation after it has been assembled in accordance with the regulations!

- › Put the fan into operation.
- › Monitor its correct function (quiet running, vibration, imbalance, power consumption, control-ability)



Always keep nozzle openings clear and secure and with handle cover.  
Check protective screens or protective anti-intrusion fittings for dirt, and clean if necessary!

## 8.3 Checks after initial start-up

Check the mechanical connections of the fan after initial start -up.

# 9 Trouble Shooting

## 9.1 Fan Help with Malfunctions

The following points must be observed in order to avoid damage to the machinery or life-threatening injury when eliminating machine malfunctions:

- › Only eliminate any malfunction if you have the specified qualifications necessary for the task.
- › First of all ensure that the machine cannot be switched on inadvertently, by locking the equipment's off switch or control cabinet by means of a padlock.
- › Secure the hazardous area with respect to moving machine parts.
- › Read the chapter "General Safety Notes".

## 9.2 Tabular overview of possible malfunctions and aids in eliminating those malfunctions

Symptom	Cause	Elimination
Motor or motor control system switches off.	Motor too hot, thermo contact activates.	Allow the motor to cool off. The fan will start itself again. Check whether: <ul style="list-style-type: none"> <li>- The conveyed medium is too hot</li> <li>- All phases are evenly loaded and connected</li> <li>- Operating point does not match the lay-out</li> <li>- Rotor blocked</li> </ul>
Air output incorrect	Incorrect direction	Change the direction of travel (see electrical assembly)
	Fan assembled incorrectly	Either the rotor is incorrectly mounted on the motor shaft or the whole motor-fan-assembly has been incorrectly fitted into the installation. Switch off the fan. Correct the incorrect assembly (rotor or motor-fan-assembly).
	Rotor blocked	Switch off the fan. Remove the blockage. Ensure that the accident prevention regulations are observed in the process.
	Rotor defective	Switch off the fan. Dismantle the rotor and fit a new one.

<p>Fan is labouring under load, air flow is periodically interrupted</p>	<p>Fan is operating at an unfavorable duty point</p>	<p>Make sure there are no obstacles at the nozzle. Please contact the Wolter for assistance. If this laboured operation of the fan continues over a prolonged period, the rotor will damage! Check if periodic maintenance and cleaning of guard was undertaken. Check against MC001.</p>
--	--	---

Table 10

## 10 General Maintenance

The following safety notes must be observed when maintaining the machine - life-threatening injuries to personnel, damage to the machine and other material damage, as well as environmental damage, will be avoided in this way.

- › Cleaning, lubrication and maintenance work may only be carried out by authorised operating personnel operating instructions are to be observed.
- › Repair work may only be carried out by authorised craftsmen - accident prevention regulations are to be observed.
- › Secure the operational area over a large area prior to the commencement of maintenance work.
- › The specified sequence of the working stages is to be observed exactly.
- › All work on the machine's electrical equipment may only be carried out by trained electricians.
- › Self-locking screws and nuts are always to be renewed.
- › All specified screw torque settings are to be observed precisely.
- › Read the chapter "General Safety Notes".



If the fan is equipped with a combined terminal box / repair switch, it is still necessary to disconnect the mains supply to the terminal box when performing electrical maintenance or repairs that require opening the terminal box!



Setting the repair switch to the "OFF" position cuts off the power supply from the terminal box to the motor, but the connection terminals inside the terminal box are still energized! When unscrewing the terminal box cover, there is a danger of contact between the cover and the connection terminals, therefore the mains supply MUST be disconnected to avoid the danger of electrical shock!

### 10.1 VE / VD Servicing

The fan housing, impeller and motor are subject to natural wear and tear through the action of dust, acidic and corrosive vapours, as well as the gases which are mixed into the conveyed flow. The type and concentration of the dust, as well as the gases and vapours, can lead to deposits, abrasion and corrosion at the impeller and housing.

The materials can be attacked by this natural wear and tear to the extent that they can no longer stand up to the strains imposed on them. Unevenly distributed deposits on the impeller may lead to an imbalanced state and thus to noisy running, which in turn can result in damage to the impeller and motor bearing. Deposits in the housing lead to a narrowing of the available cross-sectional area or to a roughening of the housing panels and can thus have an unfavorable effect on the fan's output duty. Should the checks, the regularity of which depend on the conveyed media and other operating conditions which differ in each individual case, reveal only slight wear and tear, then the individual parts must be cleaned in good time, or replaced if necessary.

### 10.2 Prior to all servicing work:

- › Bring the fan to a halt in the prescribed manner and completely isolate the fan from the mains supply!
- › Wait until the impeller has come to a halt!
- › Ensure that the machine cannot be switched on again!
- › Clean the fan components (fan housing, inlet cone, impeller, motor etc ), Do not use high-pressure water devices for cleaning



Only use cleaning agents generally available through the trade and in compliance with the prescribed safety measures. Do not use scratching or scraping tools (protective surface coating will be damaged).

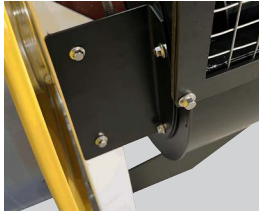

Fig.54



Fig.55

- › If required, remove the HT flexible connector. 2 Fig.54 fan angle support, inlet cone, impeller from the fan housing Fig.55.
- › Do not bend the impeller blades!
- › Do not overload the motor!

### 10.3 Recommended periodic inspection intervals

- › Fans used for normal fume and gas extraction only: 6 months
- › Fans used constantly for CO-exhaust and adverse site condition: 3 months

### 10.4 Periodic inspection checks

- › Visual inspection of motor, impeller, fan housing and electric connection for damages, dirt and dust deposits (if any)
- › Check for unusual noises or vibration during operation
- › Check tightness and security of fan suspension as per Maintenance Schedule MC001 recommendation and to avoid void on warranty

### 10.5 VE / VD Maintenance Schedule MC001

Project Name:	FAN TYPE	Maintenance No.:	
Fan Model: VE / VD Series	Centrifugal	Examiner	Date
Size: 300-13, 300-18, 300-21, 320-30, 380-47, 400-58, 500-76			
<b>JOB STEPS</b>			
<b>First inspection</b>			
- Inspection of transport damages	X		
- Inspection of fan housing	X		
- Inspection of impeller	X		
- Inspection of wire guard	X		
- Inspection of cable gland and wire connection			
<b>Inspection after mounting</b>			
- All damages to paint rectified	X		
<b>Inspection after commissioning</b>			
- Direction of rotation checked	X		
- Abnormal Vibration during operation	X		
- Abnormal Sound pressure level	X		
- Electrical values measured Voltage / Frequency / Current.....V / .....Hz / .....A	X		
<b>WORKING STEP</b>			
<b>Maintenance (at least every 6 months and depend on site condition)</b>			
- Bearing status checked / re-greased	X		
- Visual fan housing check	X		
- Visual impeller check	X		
- Visual check for corrosion	X		
- Visual motor check	X		
- Sound pressure level check	X		
- Check all screw connections of suspension construction	X		
- Electrical values measured: Voltage / Frequency / Current.....V / .....Hz / .....A	X		
- Maintenance (at least every 3 months depend on site condition)	X		
- Clean fan inlet and check any blockage	X		
- Maintenance (at least every 1 to 2 months depend on site conditon)			
- Wire Guard	X		
- Clean fan inlet and blockage check			

Table 11

# 11 The Unit Pressure Loss Calculation

The fall of pressure in a air duct system or in a hose is mainly determined by the air velocity in that system. The higher the velocity is, the higher the pressure loss will be. And the higher the pressure loss is, the less air the fan will extract. Use the Pressure loss chart below Fig. 56 to identify a suitable fan regarding the relationship between airflow and pressure loss.

In a ventilation system with many extraction devices and long suction ducts, you can minimize pressure loss by increasing the size of the ducting. This will also ensure even velocity throughout the system.

When 1200 ~ 1350 m<sup>3</sup>/h is needed, Wolter recommends a 150 mm hose. A 200 mm hose can be used for larger applications, as it supports larger engines operating under load. For those cases, the exhaust flow and temperature increase dramatically. Air velocity in ducting: 17,8 - 22,9 m/s.

The chart below shows the pressure loss in the hose reels a different airflows. Refer to the Airflow volume: general guidelines table below for the vehicle, airflow and hose diameter guidelines. The curves show these combinations of hose reel/hose diameter/hose length (uncoiled position).



We recommend that you confirm existing exhaust temperatures to ensure proper hose, fan and airflow selection

Vehicle Serviced	Airflow [CMH]	Hose Diameter [mm]
-	-	-
Motorcycles / Automobile	450 ~ 550	Ø 100
Trucks (Public works, Rental fleets, etc.)	825 ~ 950	Ø 125
Heavy Duty Trucks	1050 ~ 1400	Ø 150
Off-Road (Constr., Compressor Tests, etc.)	1650 ~ 2400	Ø 200

Table 12

Nr	Hose Diameter [mm]	Length [m]
-	[mm]	[m]
A1	Ø 100	7.5
A2	Ø 100	10
A3	Ø 100	12.5
A4	Ø 100	15
B1	Ø 125	7.5
B2	Ø 125	10
B3	Ø 125	12.5
B4	Ø 125	15
C1	Ø 150	7.5
C2	Ø 150	10
C3	Ø 150	12.5
C4	Ø 150	15
D1	Ø 200	7.5
D2	Ø 200	10
D3	Ø 200	12.5
D4	Ø 200	15

Table 13

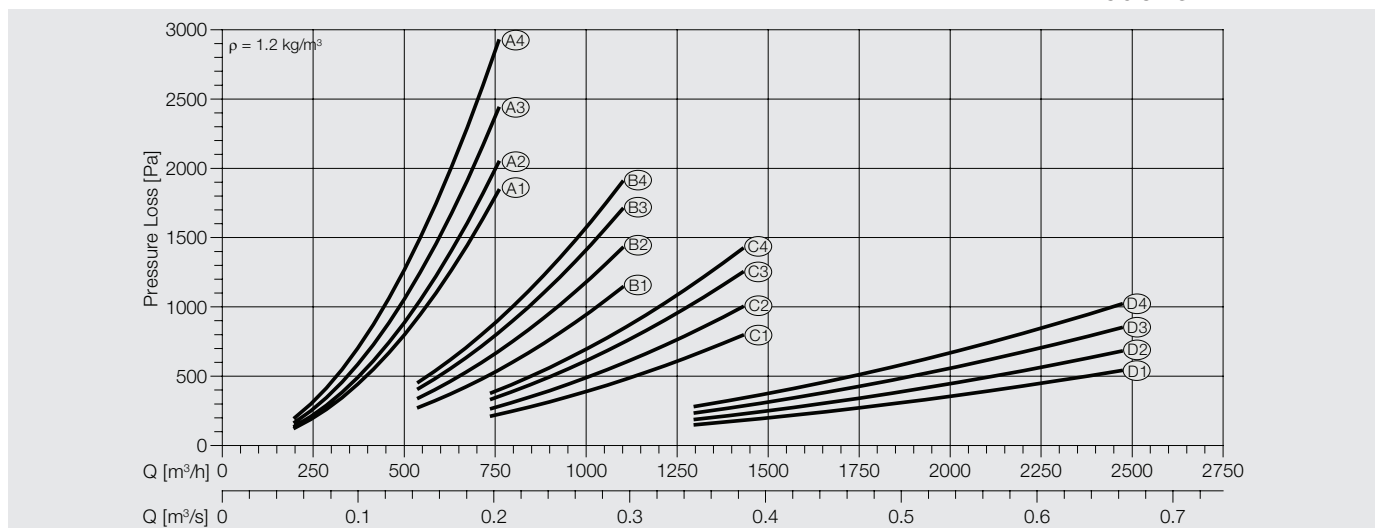
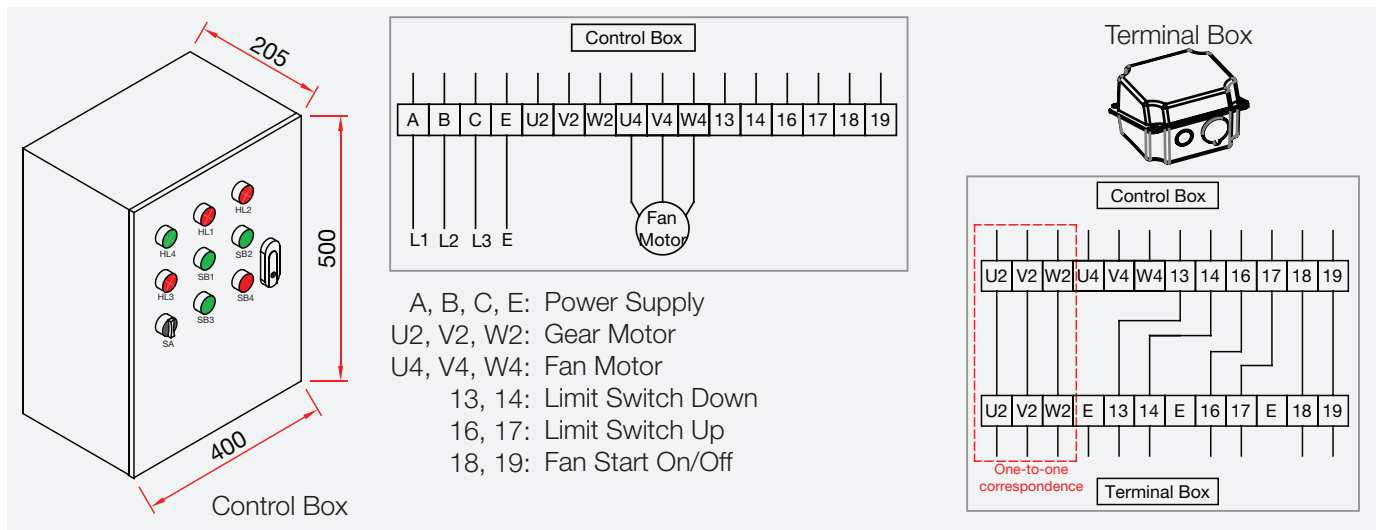
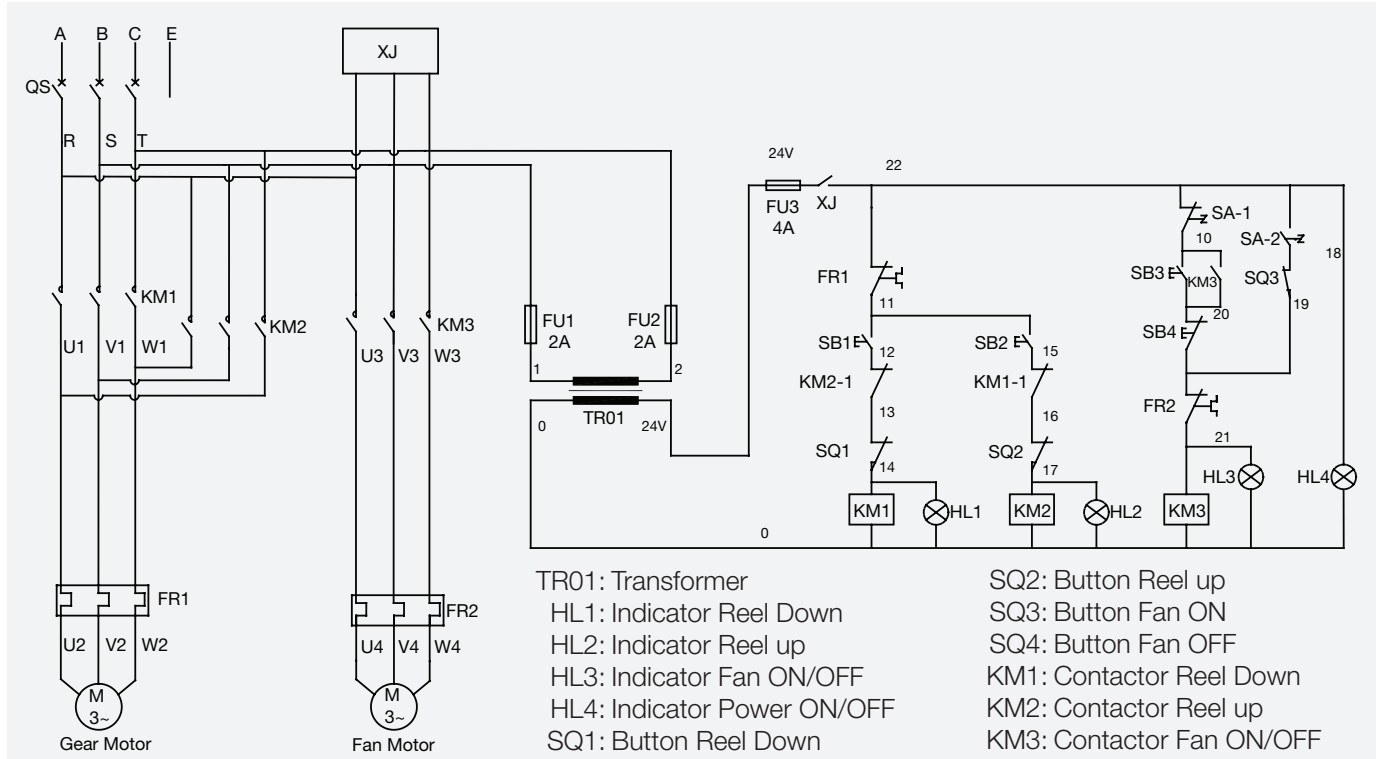

Fig.56

# 12 Electrical Wiring Diagram

VHM 400V Three-phase Wiring Diagram:



Note:

- 1) Make sure the transformer in the VHM control box is wired for 400V.
- 2) Supply voltage is customer's responsibility, and please follow the local laws and regulations.

VHM 400V Three-phase Dual Hose Reels Wiring Diagram:

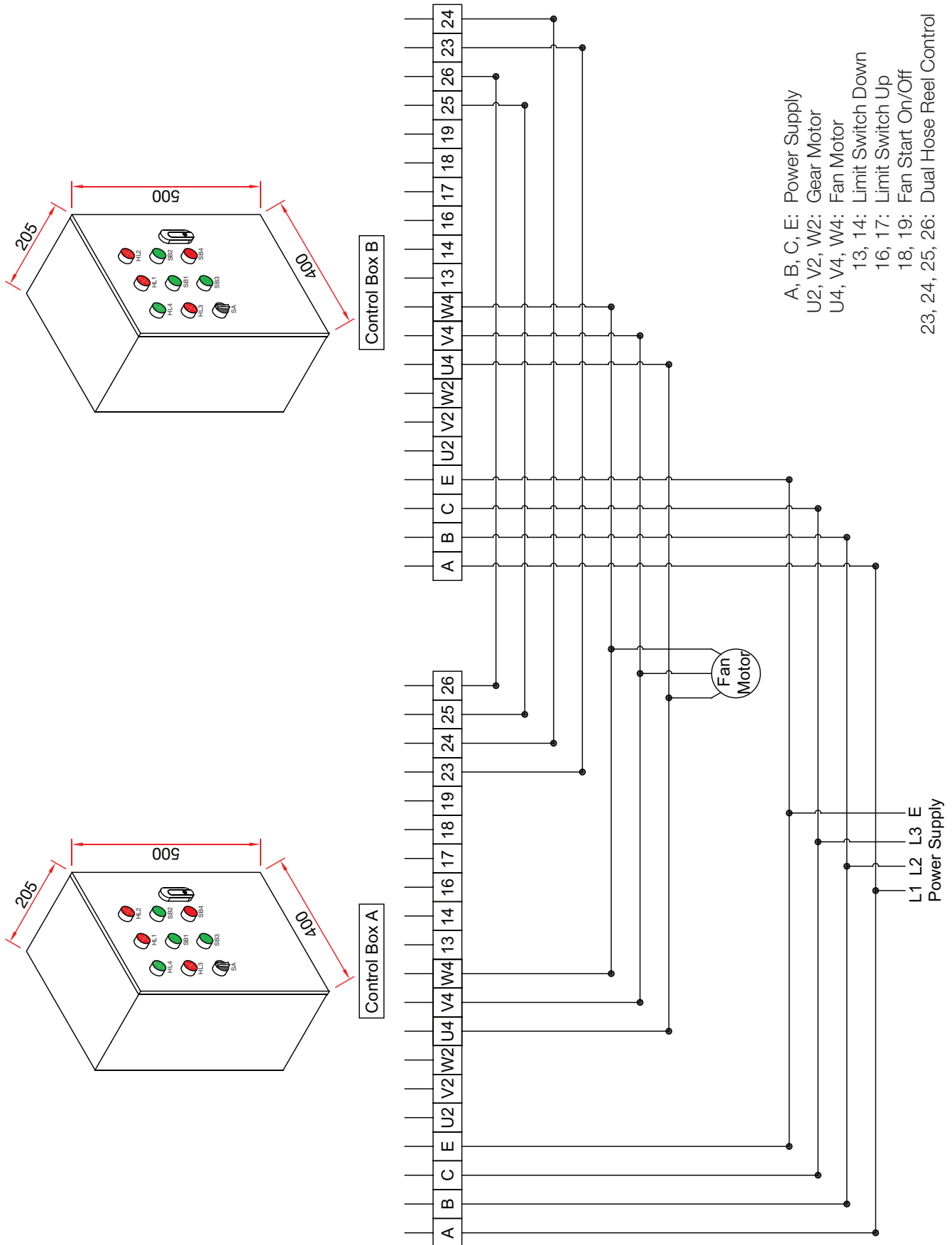

## 13 Spare Parts

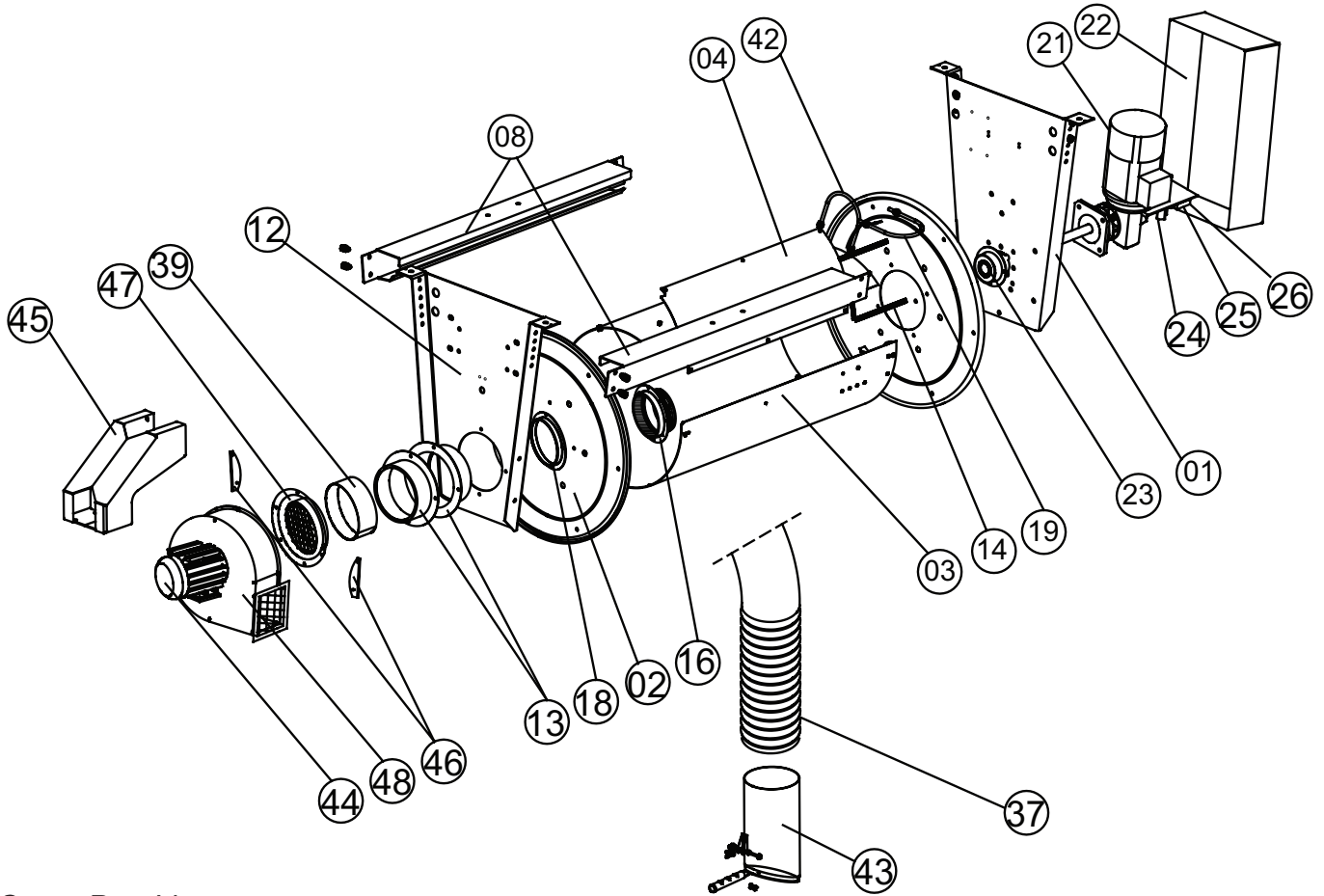

### Spare Part List

No	Part Name	VHM-850	VHM-1050	VHM-1250	No	Part Name	VHM-850	VHM-1050	VHM-1250
1	Drive Plate	01	01	01	19	U-Clamp	19	19	19
2	Casing Sideplate	02	02	02	21	Motorized Coiling Module	21	21	21
3	Reel Casing	03	03	03	22	MCM cover	22	22	22
4	Casing Cover	04	04	04	23	Flange Bearing	23	23	23
8	Base Frame	08	08	08	24	Limit Switch A1	24	24	24
12	Fan Plate	12	12	12	25	Limit Switch B1	25	25	25
13	Outlet collar	13	13	13	26	Limit Switch C1	26	26	26
14	Protection Strip	14	14	14	37	Hose	37	37	37
16	Hose bearing c/w collar	16	16	16	42	U-Guide	42	42	42
18	Fixed Collar	18	18	18	43	Standard Nozzle	43	43	43
No	Part Name	VD300-21	VD320-30	VD400-58	No	Part Name	VD300-21	VD320-30	VD400-58
39	Flexble connector	39	39	39	46	Angle bracket	46	46	46
44	Motor	44	44	44	47	Fan inlet spigot	47	47	47
45	Pedestal support	45	45	45	48	Fan Casing	48	48	48

Example: Order No VHM 1250-21 for Hose Reel model VHM1250 Motorized Coiling Module)

# Sales Network

## Deutschland

Wolter GmbH.  
Maschinen-und Apparatebau KG.  
DE-76316 Malsch  
T +49 (0) 72 04 / 92 01 0  
F +49 (0) 72 04 / 92 01 11  
info@wolter.eu

## Europe

### Denmark:

L.ØLAND VENTILATION A/S  
DK-2605 Brøndby  
T +45 (0) 70 / 20 19 11  
salg@airforce.dk

### Netherlands:

DE WIT Ventilatoren BV  
NL-3821 CG Amersfoort  
T +31 (0) 33 / 76 00 240  
info@dewitventilatoren.nl

### Sweden:

Nordisk Ventilator AB  
SE-142 50 Skogås  
T +46 (0) 8 / 72 70 250  
se@nordiskventilator.se

### Switzerland:

Anson AG Zürich  
CH-8055 Zürich  
T +41 (0) 44 / 46 11 111  
F +41 (0) 44 / 46 13 111  
info@anson.ch

### OZ Tech SA

CH-1122 Romanel-sur-Morges  
T +41 (0) 76 / 41 11 572  
info@oztech.ch

### United Kingdom:

Wolter (UK) Ltd.  
GB-Leicestershire LE65 1AL  
T +44 (0) 15 30 / 41 24 73  
info@wolteruk.com

## Middle East

### UAE, Saudi Arabia, Qatar, Lebanon:

Please contact Wolter head office

### Wolter GmbH.

Maschinen-und Apparatebau KG.  
DE-76316 Malsch  
T +49 (0) 72 04 / 92 01 0  
F +49 (0) 72 04 / 92 01 11  
info@wolter.eu

## Asia

### China:

Guangdong Wolter Chemco Ventilation Ltd.  
Boluo, Huizhou, Guangdong

Dongguan Wolter Chemco Ventilation Ltd.

Shipai, Dongguan, Guangdong  
T +86 (0) 769 / 8655 7298  
F +86 (0) 769 / 8655 7278  
info@wolter.com.hk

Taizhou Wolter Ventilation Co. Ltd.

Hengjie, Luqiao District,  
Taizhou, Zhejiang  
T +86 (0) 576 / 26 22 666 (26 52 888)  
F +86 (0) 576 / 26 56 830

### China - Hong Kong, Macau:

Wolter Asia Ltd  
Kowloon, Hong Kong  
T +852 (0) 2456 0198  
F +852 (0) 2456 0290  
info@wolter.com.hk

### China - Taiwan:

Waxlink International Co., Ltd.  
8F-2 No.218 Roosevelt Rd.,  
Sec.6, Taipei, Taiwan  
T +886 (0) 2 / 8932 1196  
F +886 (0) 2 / 8932 1197  
waxlink@mail.waxlinktw.com

## India:

Wolter Ventilators India Pvt. Ltd.  
867 D, Block-A, Sushant Lok, Phase-I,  
Gurgaon - 122009 (Haryana)  
T +91 (0) 124 2577797, 4261001-3  
sales@wolterindia.in

## Korea:

Kaceco-Wolter  
14-1, Dang-dong, Gunpo-shi,  
Gyeonggi-do  
T +(82) 0 31 / 4773 104  
F +(82) 0 31 / 4773 132  
wolter@kaceco.com  
info@kaceco.com

## Malaysia:

Vibrantech (M) Sdn Bhd.  
47200 Petaling Jaya Selangor  
T +603 (0) 7847 3500  
F +603 (0) 7847 3380  
sales@vibrantech-sb.com

## Singapore:

Wolter Pte. Ltd.  
SG-569738 Singapore  
T +65 (0) 63 / 52 95 48  
F +65 (0) 63 / 52 95 47  
info@wolterfans.com.sg

## Thailand:

Wolter Ventilation Co., Ltd.  
Thamai Kratumban Samutsakorn  
741 10 Thailand  
T +66 (0) 84 555 2936  
kongsakol@wolterfan.com

## Australia

The Sydney Fan Company.  
NSW 2147, Sydney, Australia  
T +61 (0) 2 / 9624 4000  
F +61 (0) 2 / 9624 4100  
sales@thesydneyfancompany.com

## Wolter GmbH Maschinen-und Apparatebau KG

Am Wasen 11  
DE-76316 Malsch / Germany  
T +49 (0) 72 04 / 92 01 0  
F +49 (0) 72 04 / 92 01 11  
www.wolter.eu  
info@wolter.eu

