

Wolter Induction Fans.

The innovation in compartment ventilation.

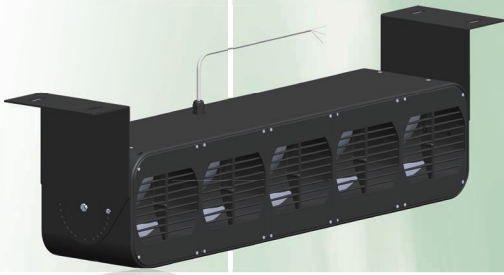

Air in Motion.

Wolter Fans.

A08.7



Wolter EC Induction Fans -

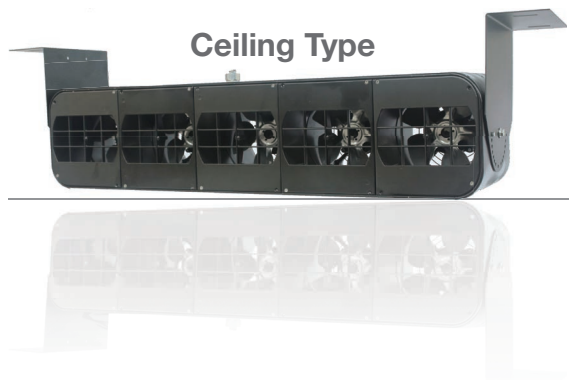

Alternative to conventional wall mounted oscillating fans and ducted ventilation system in both open and enclosed areas. Reducing energy cost by nearly 60% compared to conventional motors.

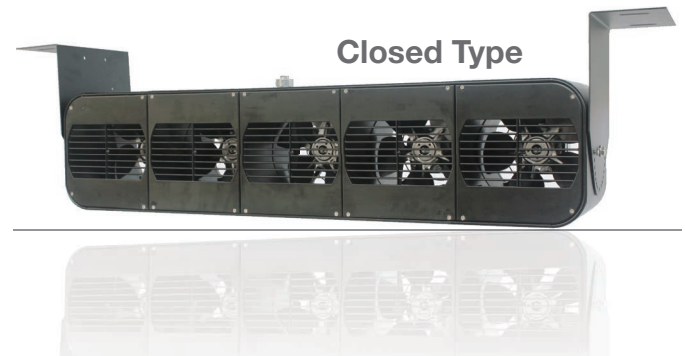

Application

In the context of a ductless Impulse Ventilation system, the architecture of a compartment itself serves as the air duct. Air velocities are much lower and there is no resistance caused by a ducted system. The total amount of energy consumed by an Impulse Ventilation system is therefore comparatively low. More importantly, in enclosed areas, the induction effect of the **Wolter Induction** fans creates a constant movement of air from the supply to the exhaust points, keeping CO levels to a minimum. A well-designed distribution of such induction fans throughout the compartment will prevent the accumulation of exhaust fumes in dead spots. The high velocity air stream along the ceiling level will induce a low-velocity airstream at floor level, ensuring the required mixing of low-level and high-level atmosphere.

Wolter Induction fans are ideal for use in underground car parks, passage ways, garages, warehouses and workshops.

Advantages

The induction fans, allow

- Uniform air distribution and no dead spots.
- Better air quality, expel stagnant, dirty exhaust gas and hot air
- Capital cost of the induction fan system is outweighed by potential savings over the traditional ducted system. ie costly installation of ductwork becomes obsolete
- Effective cooling by inducing 120% more air than normal fans
- High efficiency resulting in energy savings and fast amortization.
- Long service life and robust design
- Flexible installation and complementary with existing ductwork system
- Virtually “maintenance-free”, minimal or no maintenance cost



Wolter Induction Fan

As opposed to conventional ventilation concepts based on transverse ventilation and ducted systems, the induction fan technology is derived from the longitudinal ventilation systems found in most recent innovative ventilation system.

Here, a stream of air is injected into space by a series of free-blowing family of induction axial fans, thus inducing an air movement in addition to the natural ventilation. The decisive parameters of capacity are the air volume and velocity.

By installing an adequate number of induction fans in an enclosed compartment or car park, a constant air-movement can be created ensuring that the CO concentrations all over the areas are maintained in line with building regulations.

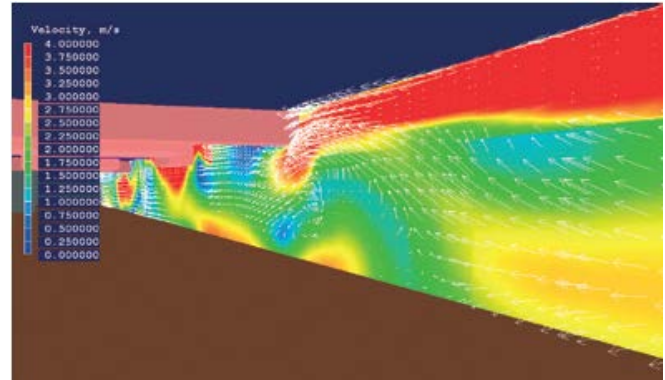

The high velocity air stream along the ceiling level will induce a low-velocity airstream at floor level, ensuring the required mixing of low-level and high-level atmosphere.

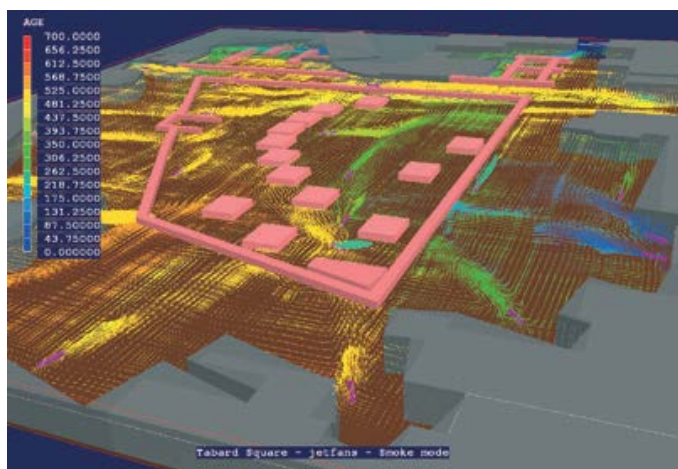
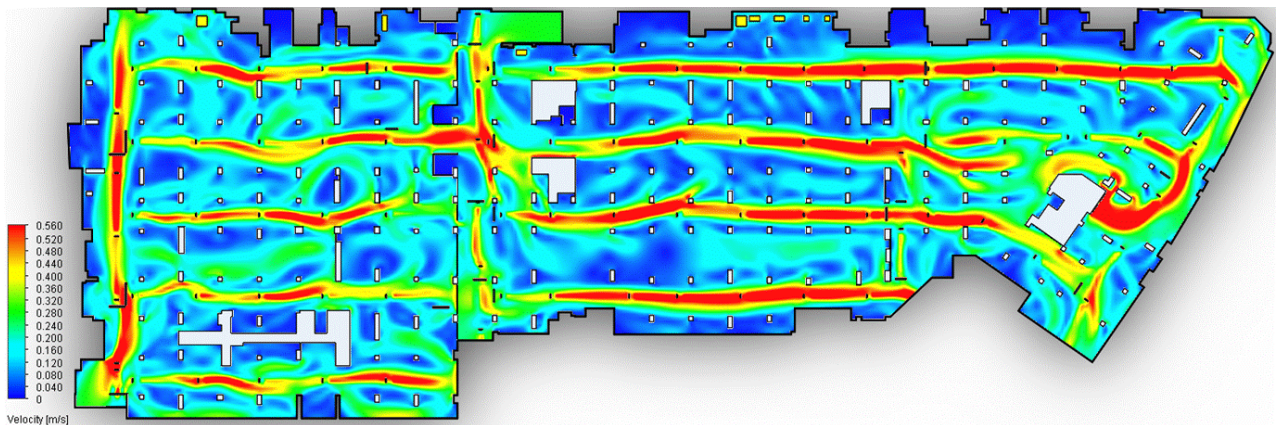

Computational-Fluid-Dynamics Design

The initial step in the design of induction fan ventilation system should always be a careful analysis of the air distribution and ventilation situation based on thorough CFD design.

CFD simulation uses purpose-built software that allows us to create a 3-dimensional image of the compartment or car park. After determining all relevant parameters such as required air-change rates, volume and air flow direction, the different

ventilation scenarios can be studied taking into account all of the above factors. The number, size and positioning of induction fans can then be optimised. CFD software visualizes direction vectors of airflows and mean age of air distribution in all areas of the compartment or underground car park. CFD design can also be used to simulate the fume distribution throughout the compartment and the induction fans can be positioned accordingly.

Wolter will be happy to assist you early during the design stage of your induction ventilation project.

Wolter Induction Fan

Manufactured to cover all profile requirements in relevant specifications and incorporated with high efficient motors that are generally maintenance-free.

Beside the existing A/C E series, a new registered design feature of the WOLTER EC Induction Fan helps reduce energy costs by nearly 60% compare to conventional motor. Moreover, it allows a 120% increase in the amount of airflow through induction to guarantee ventilation in every corner of the area.

Technical Information

- **Impeller:**

Fan impellers are of rigid aluminum sheet. Impeller shall dynamically balanced balance in accordance to grade G2.5 - ISO 21940-11 / AMCA 204 or class Q2.5 - VDI 2060 and tested for over speed. Impellers are of axial type and designed to give maximum volume flow with minimum noise level and minimum power consumption.

- **EC motor / isolator switch:**

The unit comes with a number of motorized impellers to give a high volume flow and induction capability. Mounted with wire guard and equipped with three different speeds to suit the respective site requirements in unidirectional airflow direction.

EC motors need to be totally enclosed single-phase induction motor with Polyamide Housing (UL94-V0) for better dampening effect and of Class B, IP 55 with 1/3 of the heat loss compared to those normally incurred by a conventional AC or 3-phase motor. The motor to be of high efficiency with power supply at single phase 230VAC \pm 10% at 50Hz (Operation voltage range at 208VAC ~ 264VAC), life test at \geq 45000hrs. Motors are connected to an external terminal box. Each induction fan unit has a starting current lower than 1A under high speed mode.

The unit can be adaptable to connect with a remote controller or field made control panel for remote On / Off and High / Low speeds operation.

The Induction fan can operate continuously under environment temperature range of -30°C+60°C and with less than 25% to 90% RH.

All motors to be tested in accordance to IEC Regulations.

- **Housing:**

Fan housing side steel plate come with powder coated finish. The top and bottom housing plates should be of heavy duty extruded, anodized or powder coated to give a smooth surface finish to withstand humid and corrosive environments. Standard color is Black with other colors (white or grey) as optional.



The low profile fan housing of the induction fan is manufactured as one integral unit to minimise headroom obstruction. The overall low profile height of the unit is 298 mm. They do not significantly obstruct headroom heights within the compartment or car park space. Isolator switches, speed control, alarm function, lockable isolator switch can be fitted as optional extras.

- **Fan inlet cone and outlet tube:**

Each module consists of a set of precision die casted aluminum alloy inlet with rotor unit and aerodynamically shaped outlet with CE approved built-in guide vanes to give maximum air performance at low noise and a smooth velocity profile.

The J Series comes with 1, 2, 3, 4, 5, 6 or 8 fan units of modular design. Each individual motor unit / outlet tube can be easily removed to facilitate routine servicing. Therefore, it is not necessary to dismount the entire fan from the ceiling for revision or maintenance purpose.

- **Wire guard protective screen:**
Inlet protective screen comply with factory tested BS3042 finger proof requirements. The screen is fitted to the motor side as appropriate in accordance to CE requirements. Protective screen shall be of low carbon steel wire or rod with powder coating.
- **Mounting brackets and airflow direction:**
Mounting brackets are made of powder coated rigid steel sheet and provided as required for the proper installation of equipment. The mounting leg can be positioned outwards or inwards to suit different applications and mounting directions, the angles of the Induction fan must be adjustable to at least eight different angles from horizontal to vertical positions. Induction fan can be installed by means of simple mounting with suspension bolts from ceilings or walls.
- **Performance Test:**
Air performance tested in accordance to AMCA 210 standard in an AMCA accredited laboratory.
Sound performance tested in accordance to AMCA 300 standard in an AMCA accredited laboratory.



AXV Axial Fan to supplement Main Exhaust and Supply Fans

The induction fan in operation provides sufficient airflow at longitudinal direction in series thus this guaranteed the exhaust fumes are directed to the nearest exhaust point located with the Main Exhaust fan. Adequately sized main exhaust fans are therefore an important part of the overall system.

Where the natural air supply is insufficient, supply fans may have to be installed.

Sensor and Control Technology

The sensor and control technology is a very important integral part of the induction fan system. The requirement for CO-sensors in a compartment or car park has to be individually determined during the design stage. The exhaust flow and running pattern also have to be carefully designed in order to determine exactly which fans have to be put in a specific area. Some fans can serve as standby units only and can be started automatically if certain maximum levels of air pollution are exceeded. EC motors can be designed to offer certain additional functions such as open or closed loop speed control, alarm function etc.

Technical Data

EC Motor - Power Supply 50Hz 208V ~ 264V

Model Size	Fan speed [-]	Power [W]	Running current [A]	Starting current [A]	Volume flow [m ³ /h]	Velocity at max volume [m/s]	Velocity at free flow [m/s]	Sound pressure [dB(A)]	Weight [kg]
J9-10	High	22	0,20	0,26	980	4,46	4,05	39 ~ 40	17
	Medium	12	0,13	0,17	740	3,37	3,07	33 ~ 35	
	Low	8	0,10	0,13	570	2,60	2,37	27 ~ 29	
J9-15	High	31	0,28	0,37	1280	5,95	5,41	45 ~ 47	17
	Medium	23	0,24	0,32	1140	5,18	4,71	42 ~ 44	
	Low	16	0,16	0,21	920	4,19	3,81	37 ~ 39	
J1-20	High	11	0,12	0,18	310	7,35	6,68	47 ~ 49	7
	Medium	8	0,08	0,11	270	6,46	5,87	42 ~ 45	
	Low	6	0,06	0,09	220	5,18	4,71	38 ~ 40	
J3-20	High	21	0,24	0,30	620	7,35	6,68	48 ~ 50	9
	Medium	16	0,15	0,18	530	6,46	5,87	43 ~ 45	
	Low	11	0,12	0,15	430	5,18	4,71	39 ~ 40	
J5-20	High	30	0,30	0,45	980	7,35	6,68	49 ~ 51	11
	Medium	22	0,19	0,27	850	6,46	5,87	44 ~ 46	
	Low	15	0,14	0,21	690	5,18	4,71	40 ~ 41	
J7-20	High	40	0,40	0,54	1300	7,35	6,68	50 ~ 52	14
	Medium	29	0,26	0,34	1130	6,46	5,87	45 ~ 47	
	Low	20	0,21	0,29	910	5,18	4,71	40 ~ 42	
J9-20S	High	47	0,51	0,67	1630	7,35	6,68	52 ~ 54	17
	Medium	35	0,32	0,42	1410	6,46	5,87	47 ~ 49	
	Low	23	0,24	0,32	1140	5,18	4,71	42 ~ 44	
J9-20H	High	99	0,99	1,31	2200	10,31	9,37	58 ~ 60	17
	Medium	47	0,51	0,67	1630	7,35	6,68	52 ~ 54	
	Low	23	0,24	0,32	1140	5,18	4,71	42 ~ 44	
J11-20	High	57	0,61	0,98	1960	7,35	6,68	54 ~ 56	20
	Medium	42	0,38	0,61	1690	6,46	5,87	49 ~ 51	
	Low	27	0,29	0,36	1380	5,18	4,71	44 ~ 46	
J15-20	High	76	0,81	1,30	2610	7,35	6,68	57 ~ 59	27
	Medium	56	0,51	0,82	2250	6,46	5,87	52 ~ 54	
	Low	36	0,38	0,61	1830	5,18	4,71	47 ~ 49	
J9-30	High	99	0,99	1,31	2200	10,31	9,37	58 ~ 60	17
	Medium	76	0,75	0,99	1990	9,29	8,45	53 ~ 55	
	Low	61	0,60	0,79	1820	8,54	7,76	51 ~ 53	

Note: 1, The volume flow indicated above is measured in chamber at 0 static pressure, other values are measured at free flow at 230V/50Hz;

2, The sound pressure dB(A) is measured at the distance of 1,5m at 45 degree from the outlet;

3, We reserve the right to alter measurements without notice in case of technical improvements.

Technical Data

AC Motor - Power Supply 50Hz 210V ~ 260V

Model	Fan Speed [-]	Power [W]	Running Current [A]	Starting Current [A]	Volume Flow [m3/h]	Velocity at Max Volume [m/s]	Velocity at Free Flow [m/s]	Sound Pressure [dB(A)]	Weight [kg]
J5-E-20	High	78	0,41	0,67	980	7,35	6,68	49 ~ 51	11
	Low	62	0,38	0,59	690	5,18	4,71	40 ~ 41	
J7-E-20	High	104	0,54	0,86	1300	7,35	6,68	50 ~ 52	14
	Low	83	0,50	0,66	910	5,18	4,71	40 ~ 42	
J9-E-20	High	131	0,68	1,09	1630	7,35	6,68	52 ~ 54	17
	Low	104	0,63	0,81	1140	5,18	4,71	42 ~ 44	
J11-E-20	High	157	0,82	1,30	1960	7,35	6,68	54 ~ 56	20
	Low	124	0,76	1,19	1380	5,18	4,71	44 ~ 46	
J15-E-20	High	209	1,09	1,74	2610	7,35	6,68	57 ~ 59	27
	Low	166	1,01	1,61	1830	5,18	4,71	47 ~ 49	
J5-E-30	High	136	0,62	1,02	1330	10,31	9,37	56 ~ 58	11
	Low	105	0,49	0,80	980	7,35	6,68	50 ~ 52	
J7-E-30	High	181	0,83	1,31	1760	10,31	9,37	57 ~ 59	14
	Low	140	0,66	1,04	1300	7,35	6,68	51 ~ 53	
J9-E-30	High	226	1,04	1,66	2200	10,31	9,37	59 ~ 61	17
	Low	175	0,82	1,31	1630	7,35	6,68	53 ~ 55	
J11-E-30	High	271	1,25	1,98	2650	10,31	9,37	61 ~ 63	20
	Low	210	0,98	1,56	1960	7,35	6,68	55 ~ 57	
J15-E-30	High	362	1,66	2,66	3530	10,31	9,37	64 ~ 66	27
	Low	280	1,31	2,10	2610	7,35	6,68	58 ~ 60	

Note: 1, The volume flow indicated above is measured in chamber at 0 static pressure, other values are measured at free flow at 220V/50Hz;

2, The sound pressure dB(A) is measured at the distance of 1,5m at 45 degree from the outlet;

3, * All A/C motor operating input at design condition shall be added with safety factor unless otherwise specified.

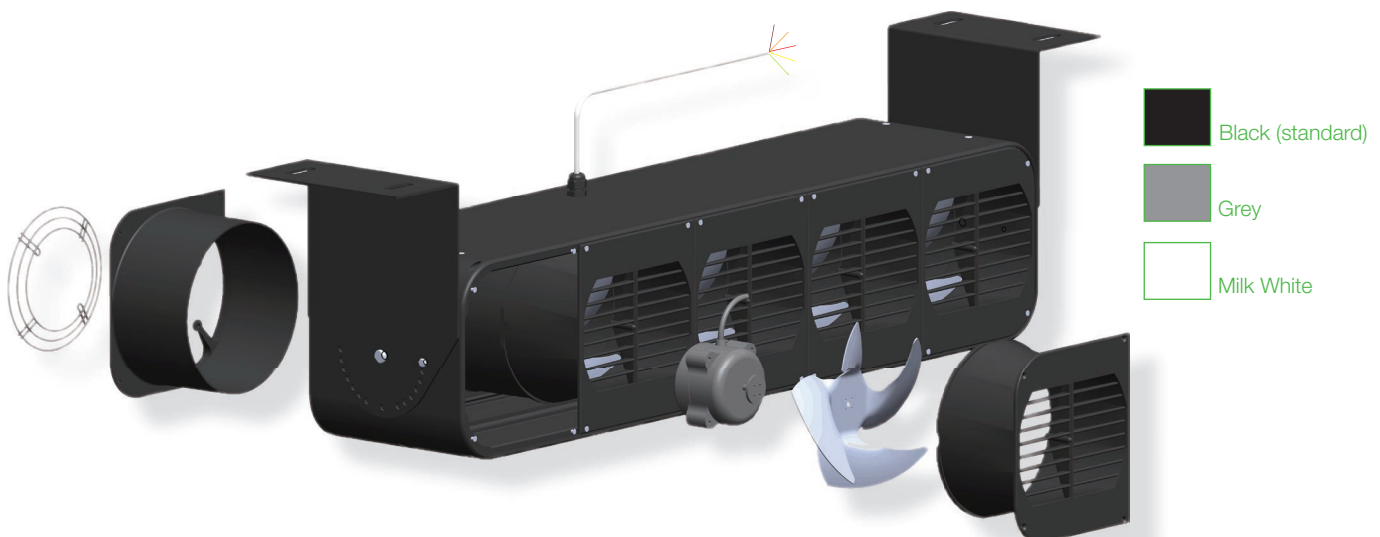

Performance curves

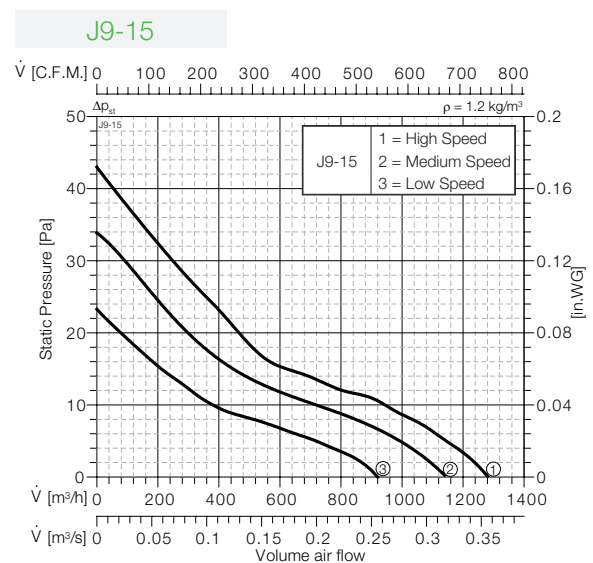
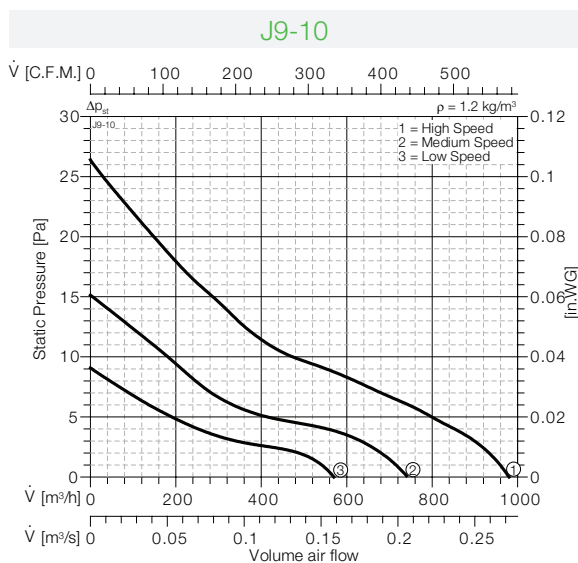
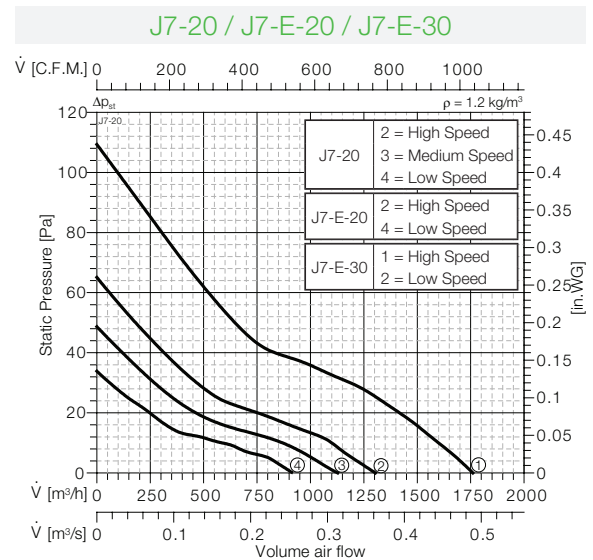
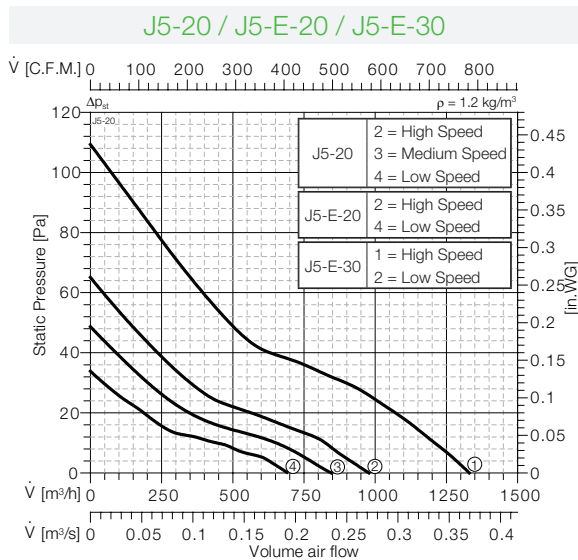
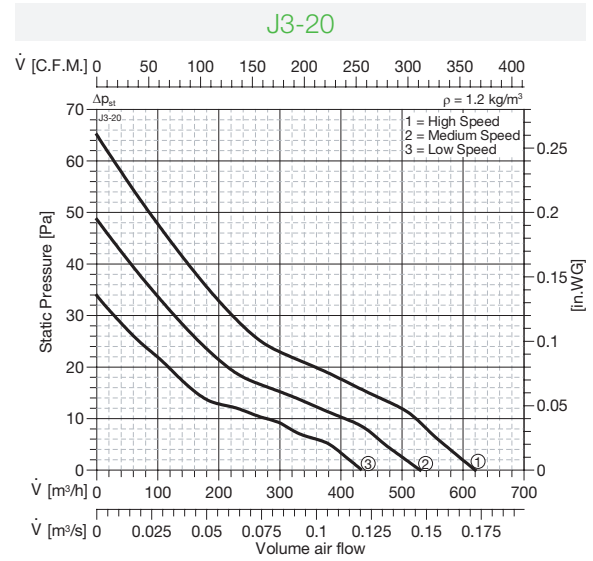
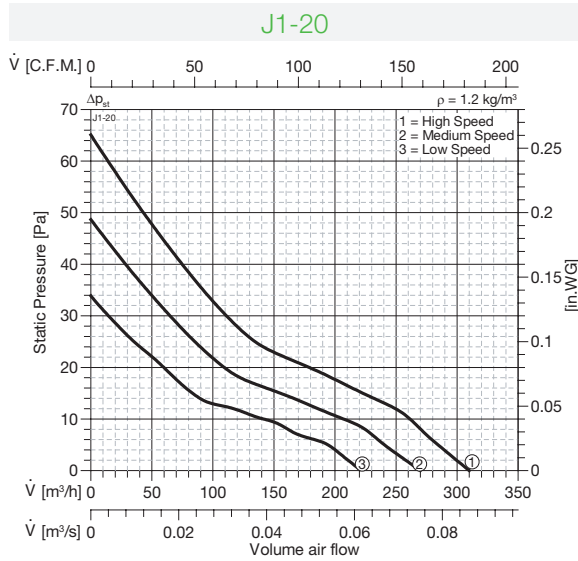

Note: The above data were obtained in a laboratory accredited by AMCA for AMCA Standard 210 testing.

Performance curves

J9-20 / J9-E-20 / J9-E-30

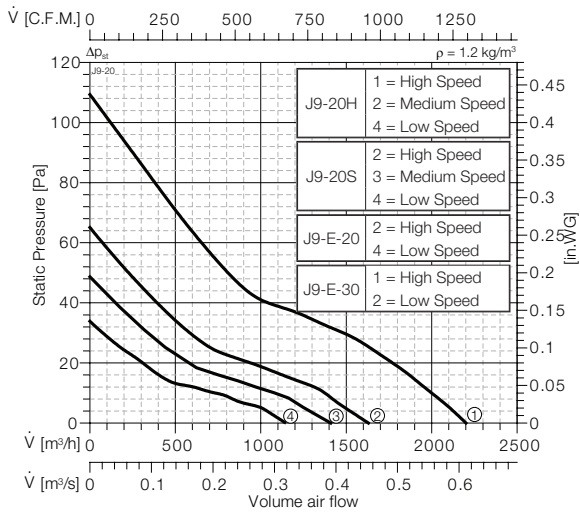

J9-30

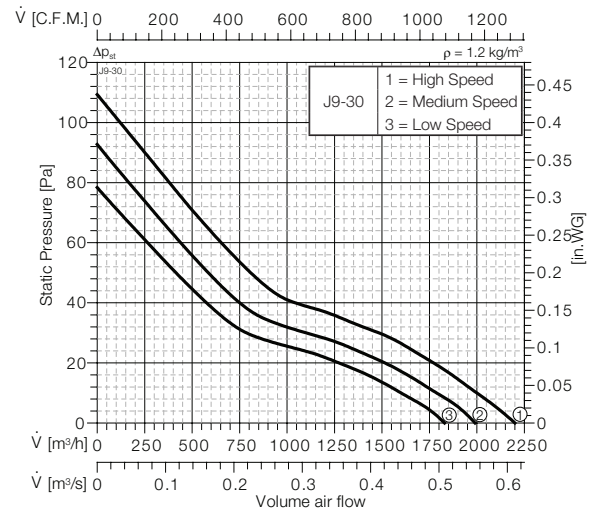

J11-20 / J11-E-20 / J11-E-30

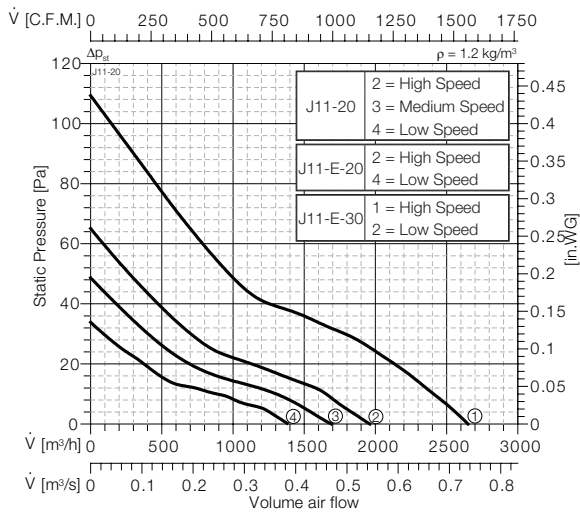

J15-20 / J15-E-20 / J15-E-30

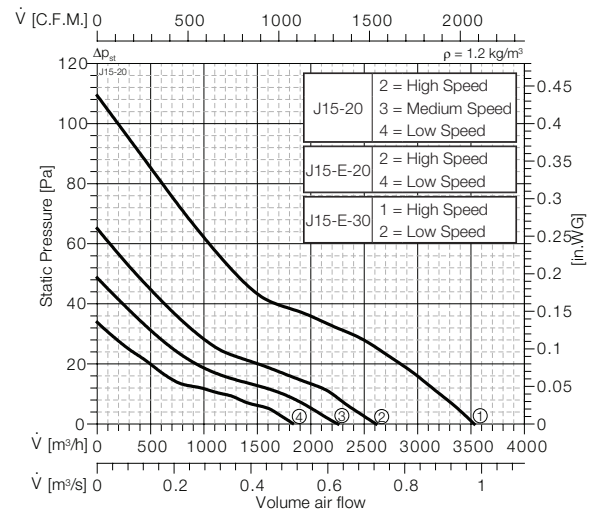

Note: The above data were obtained in a laboratory accredited by AMCA for AMCA Standard 210 testing.

Dimensions

Approx. 1 Meter as standard
Different wire length optional.

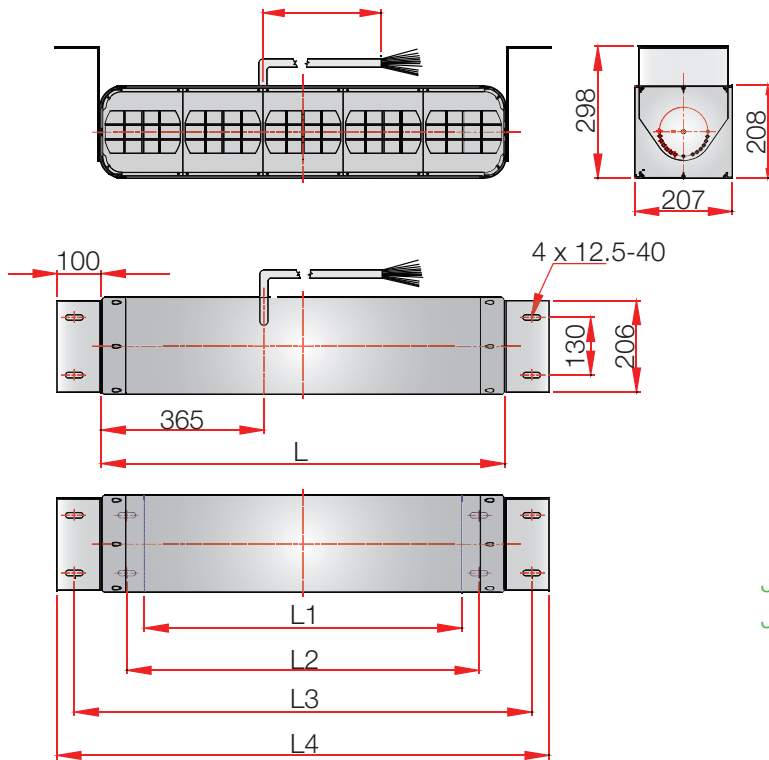

The mounting angle of the unit body can be adjusted in 8 steps.
(0°, 11.3°, 22.5°, 33.8°, 45°, 56.3°, 67.5°, 90°)

Examples of Closed Type:
J3, J1

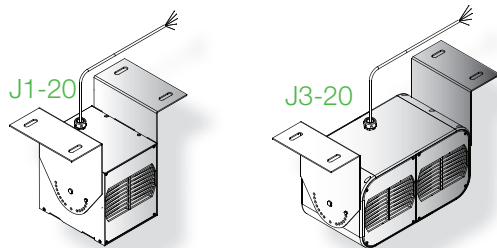

Examples of Closed Type:
J15, J11

J15-20
J15-E-20
J15-E-30

J11-20
J11-E-20
J11-E-30

Examples of Ceiling Type:
J9, J7, J5

J9-10
J9-15
J9-20
J9-E-20
J9-30
J9-E-30

J5-20
J5-E-20
J5-E-30

J7-20
J7-E-20
J7-E-30

Model Size	L [mm]	L1 [mm]	L2 [mm]	L3 [mm]	L4 [mm]
J1-20	182	-	-	308	387
J3-20	375	177	257	496	577
J5-20 / J5-E-20 / J5-E-30	548	354	432	670	748
J7-20 / J7-E-20 / J7-E-30	730	535	613	851	930
J9-10,15, 20, 30 / J9-E-20 / J9-E-30	910	718	798	1037	1117
J11-20 / J11-E-20 / J11-E-30	1090	899	979	1218	1298
J15-20 / J15-E-20 / J15-E-30	1452	1260	1340	1580	1660

Note: We reserve the right to alter measurements without notice in case of technical improvements

Air Velocity Profile (J1-20)

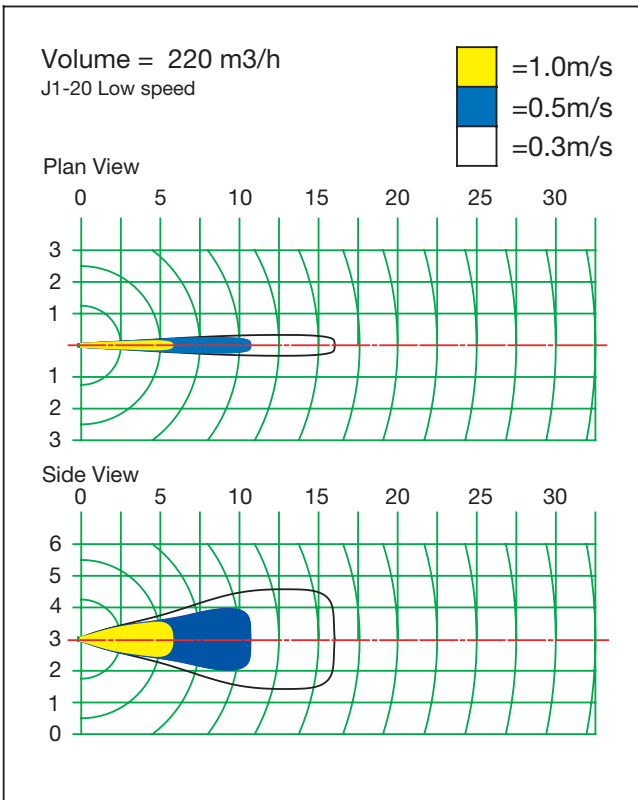
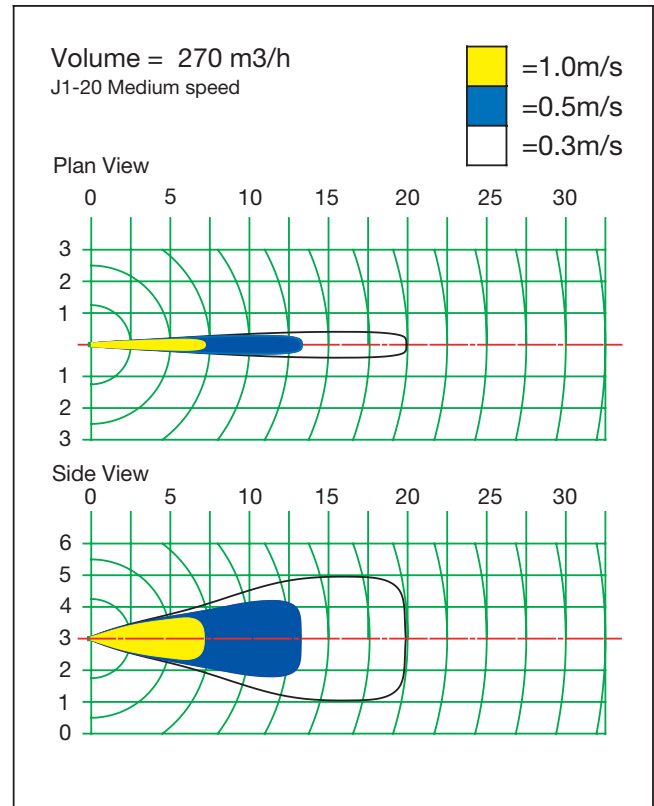
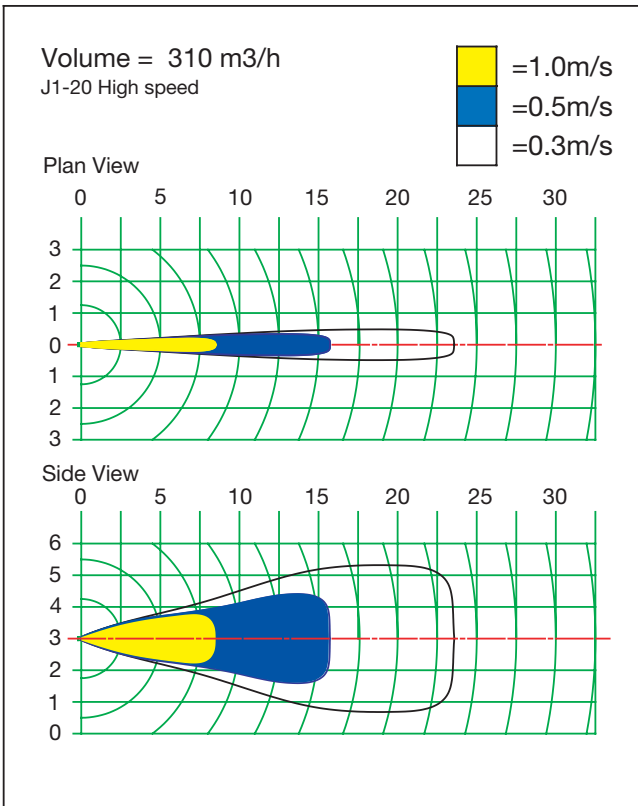

All scale in meter

Note: We reserve the right to alter measurements without notice in case of technical improvements

Air Velocity Profile (J3-20)

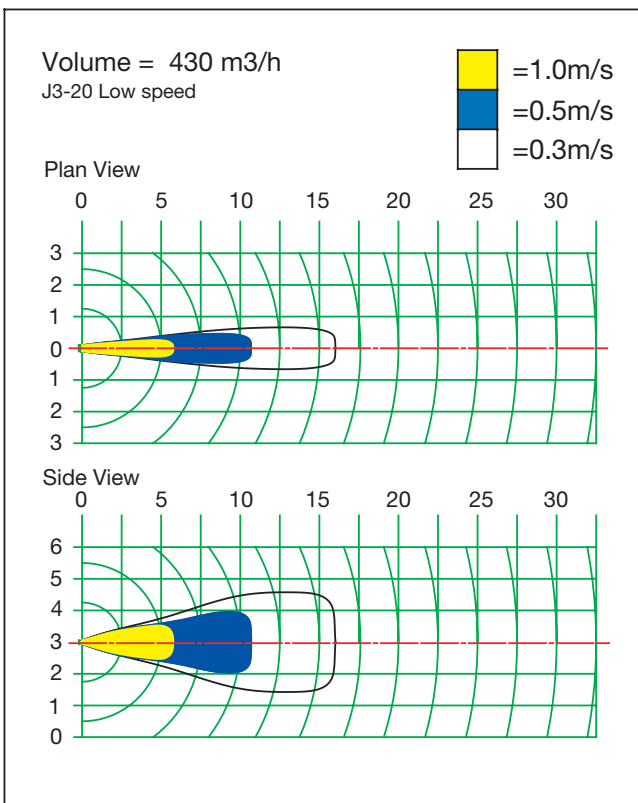
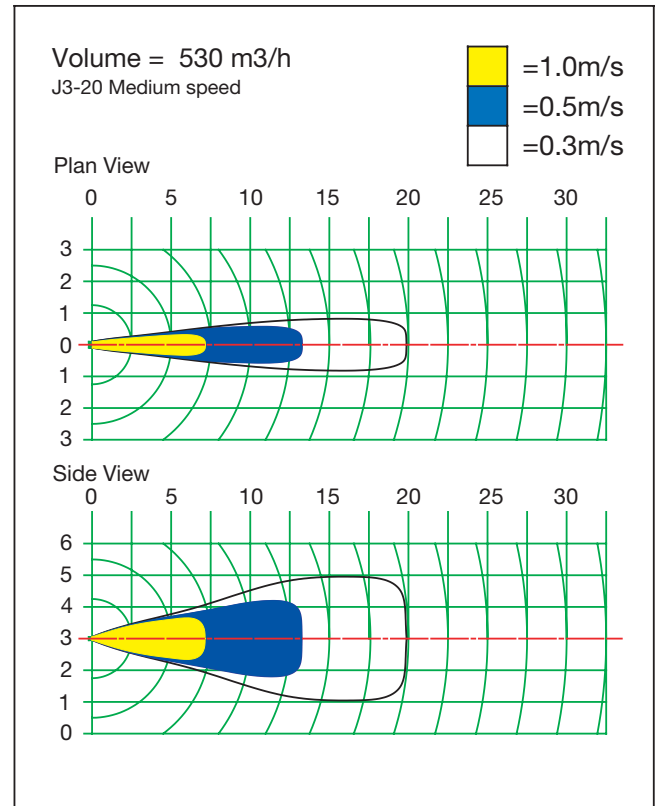
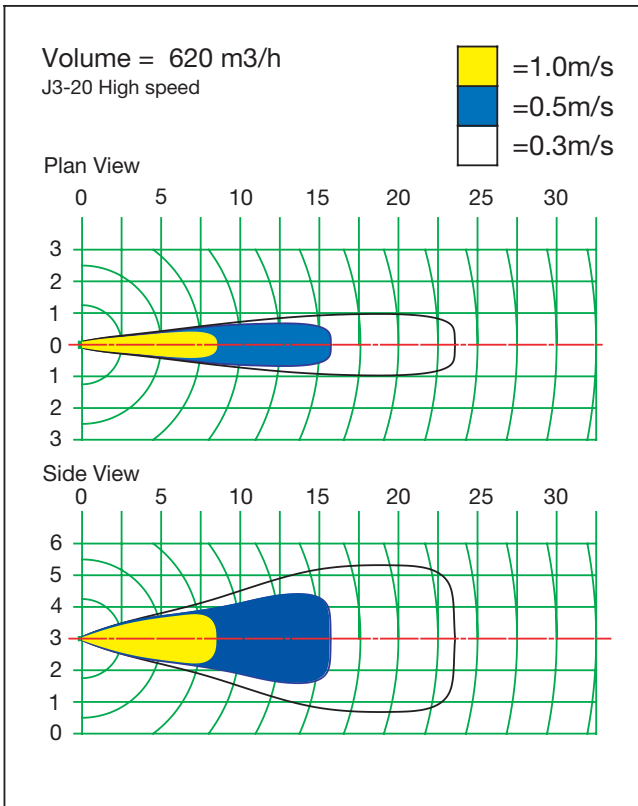

All scale in meter

Note: We reserve the right to alter measurements without notice in case of technical improvements

Air Velocity Profile (J5-20, J5-E-20, J5-E-30)

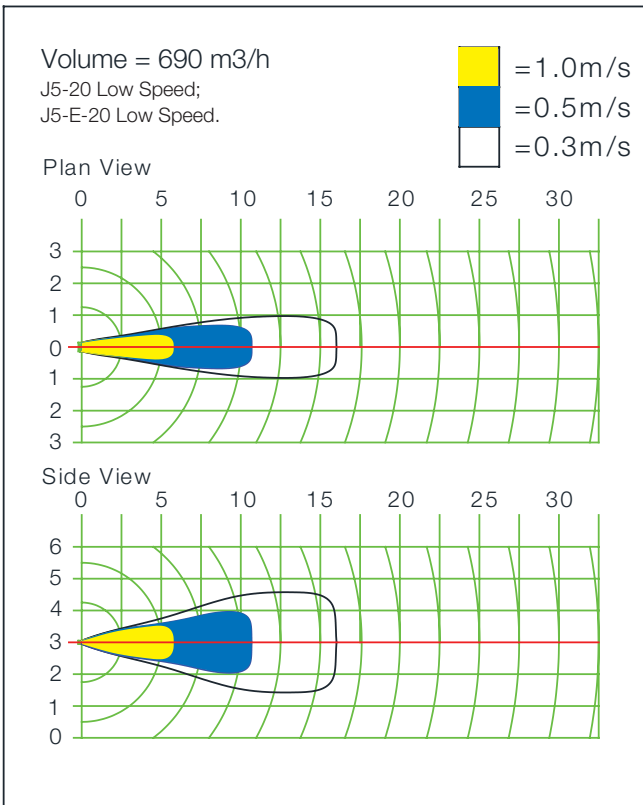
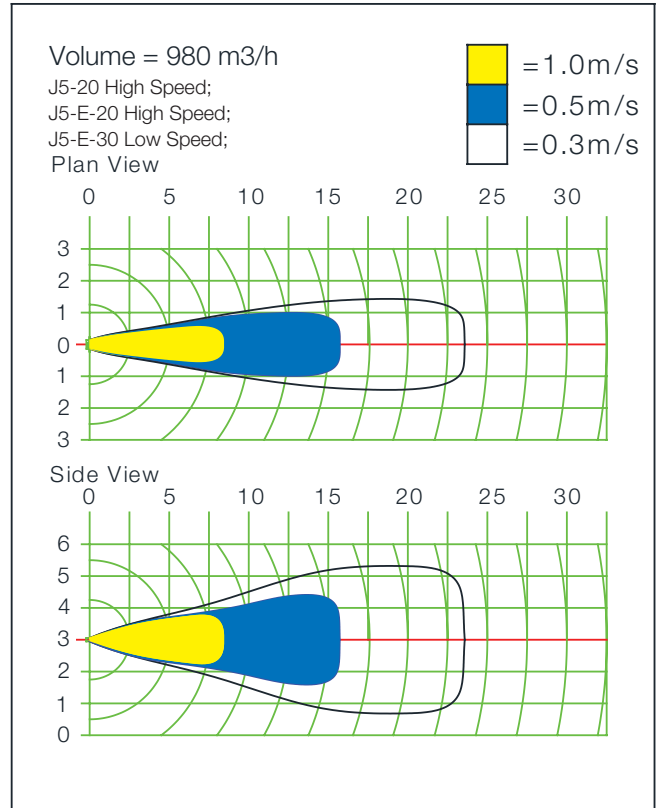
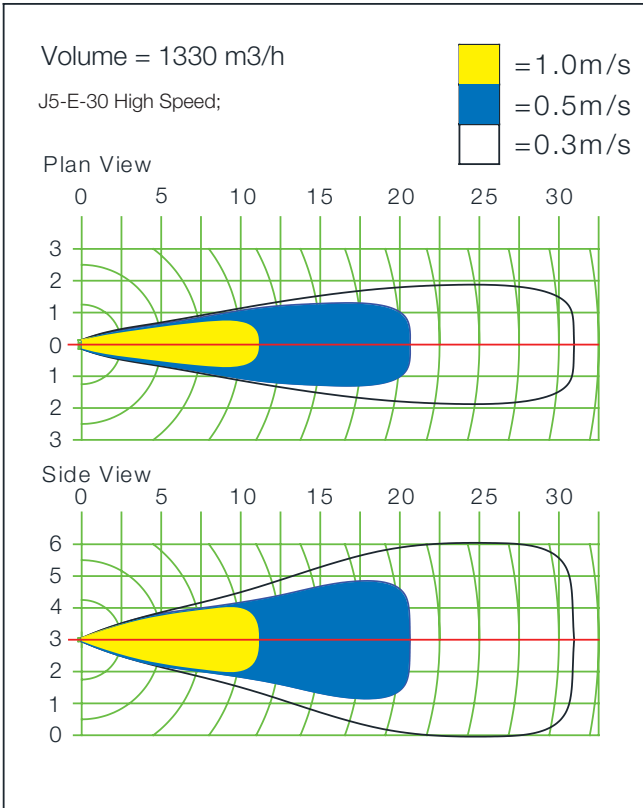

All scale in meter

Note: We reserve the right to alter measurements without notice in case of technical improvements

Air Velocity Profile (J7-20, J7-E-20, J7-E-30)

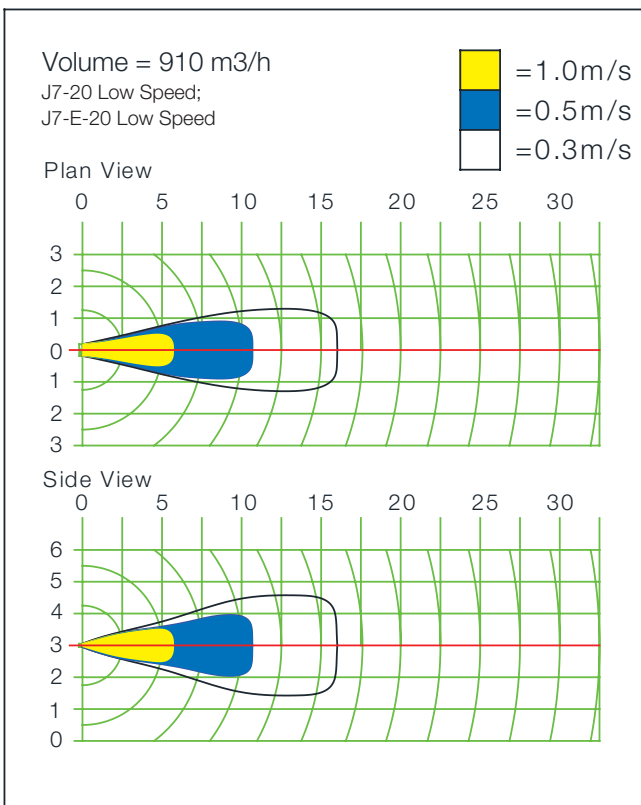
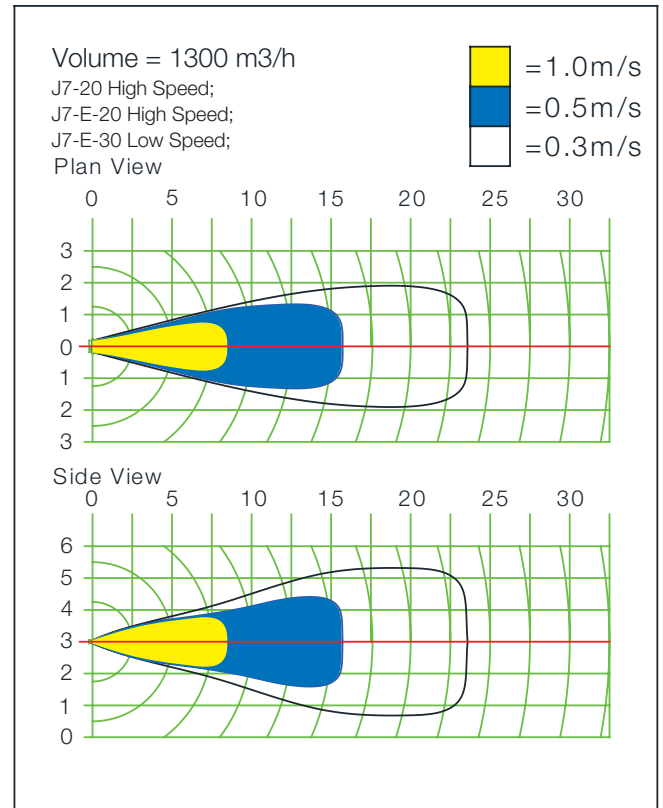
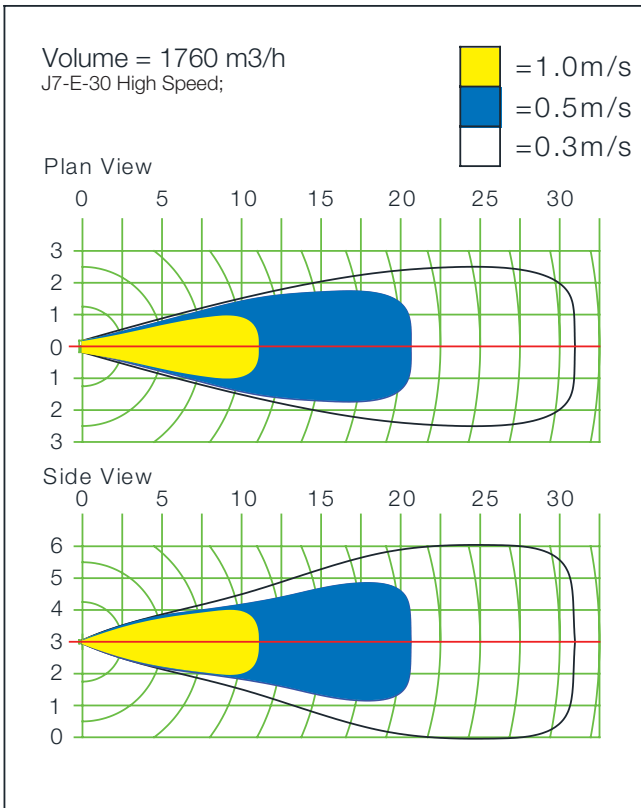

All scale in meter

Note: We reserve the right to alter measurements without notice in case of technical improvements

Air Velocity Profile (J9-10)

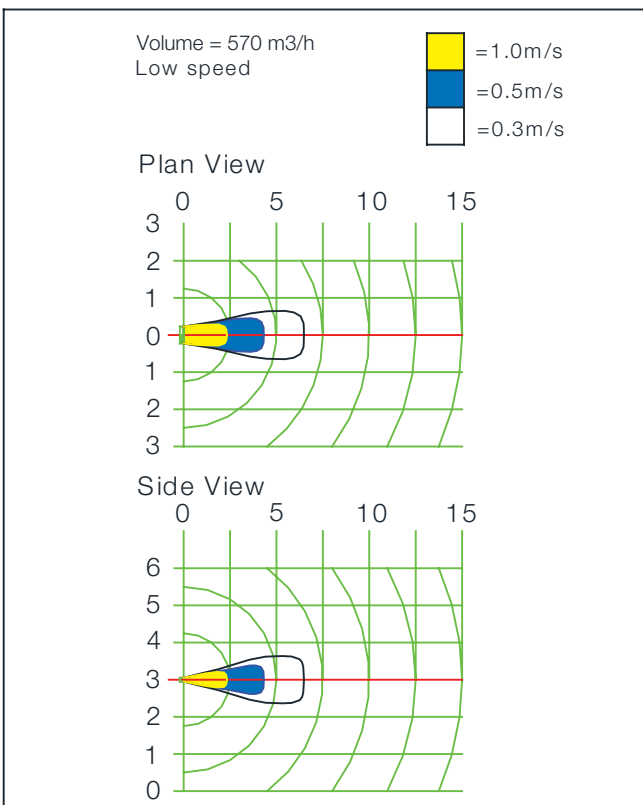
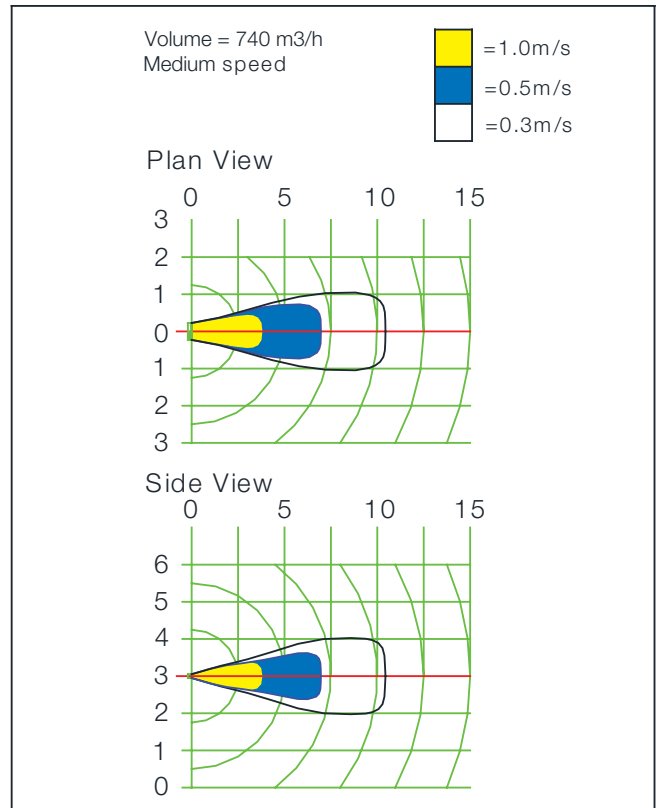
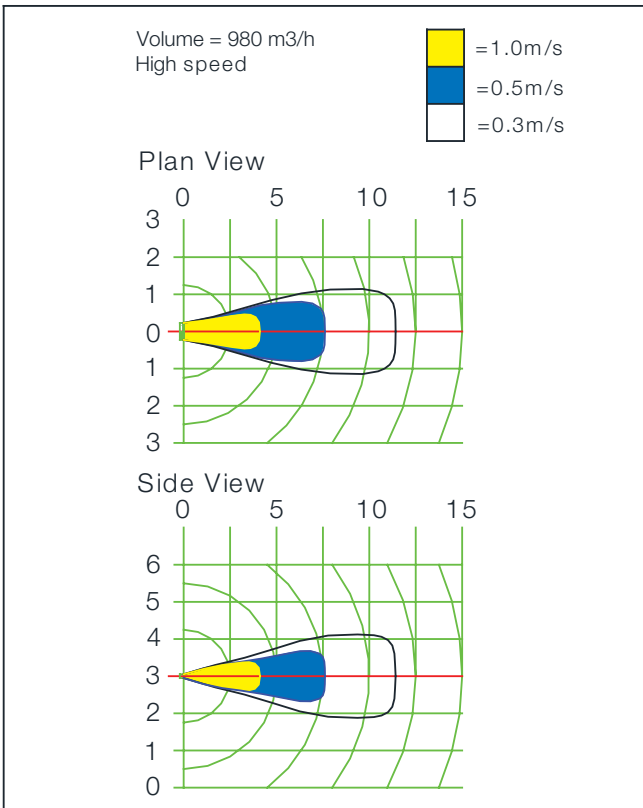

All scale in meter

Note: We reserve the right to alter measurements without notice in case of technical improvements

Air Velocity Profile (J9-15)

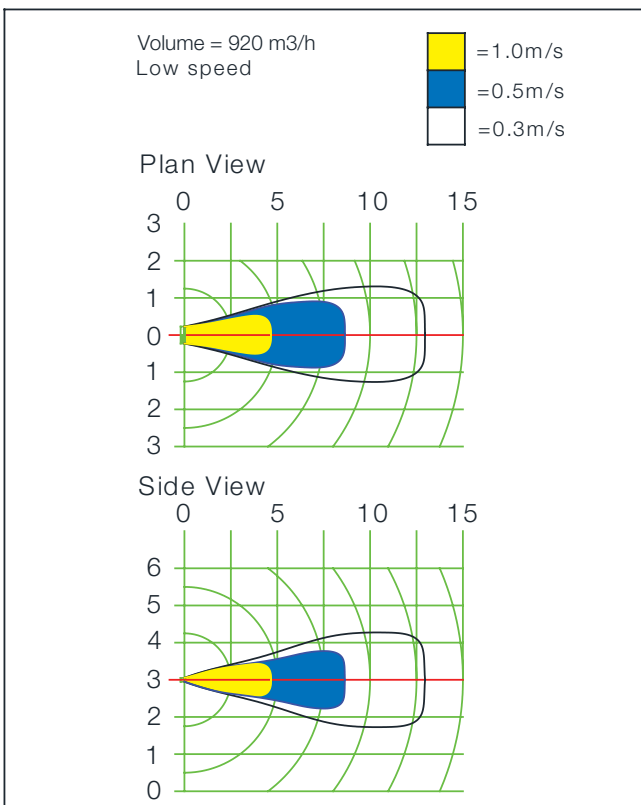
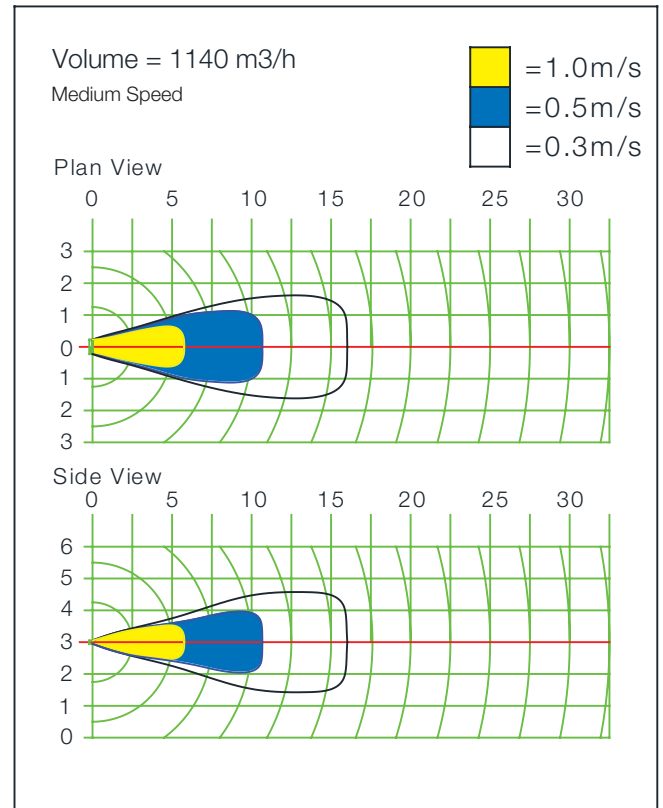
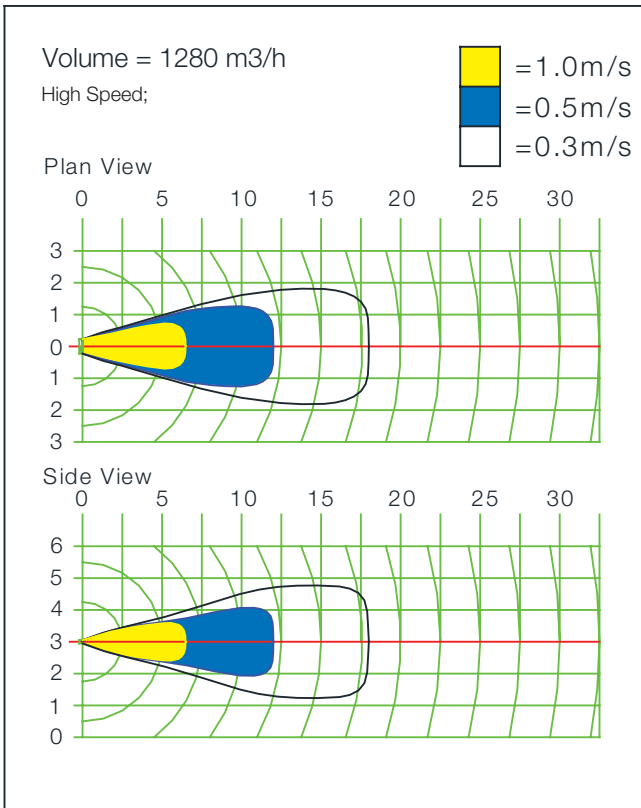

All scale in meter

Note: We reserve the right to alter measurements without notice in case of technical improvements

Air Velocity Profile (J9-20S, J9-20H, J9-E-20, J9-E-30)

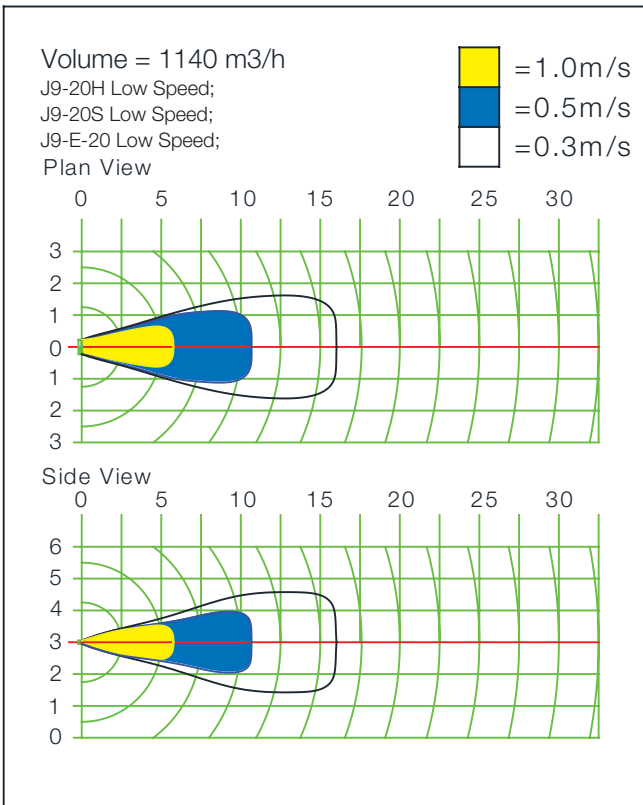
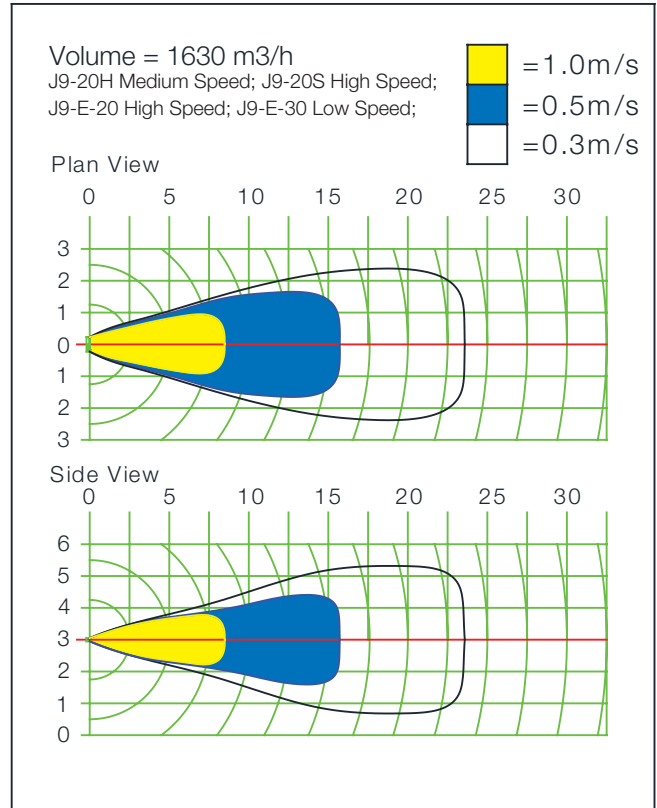
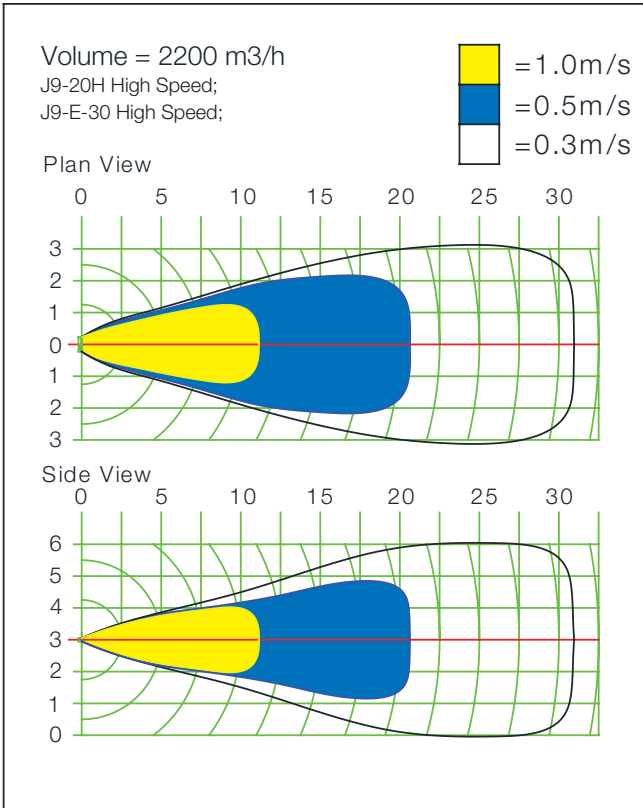

All scale in meter

Note: We reserve the right to alter measurements without notice in case of technical improvements

Air Velocity Profile (J9-30)

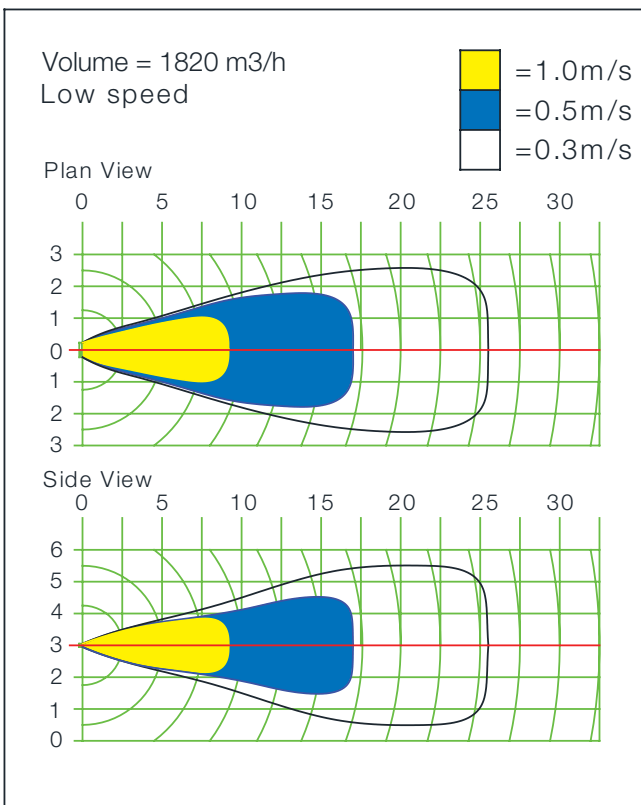
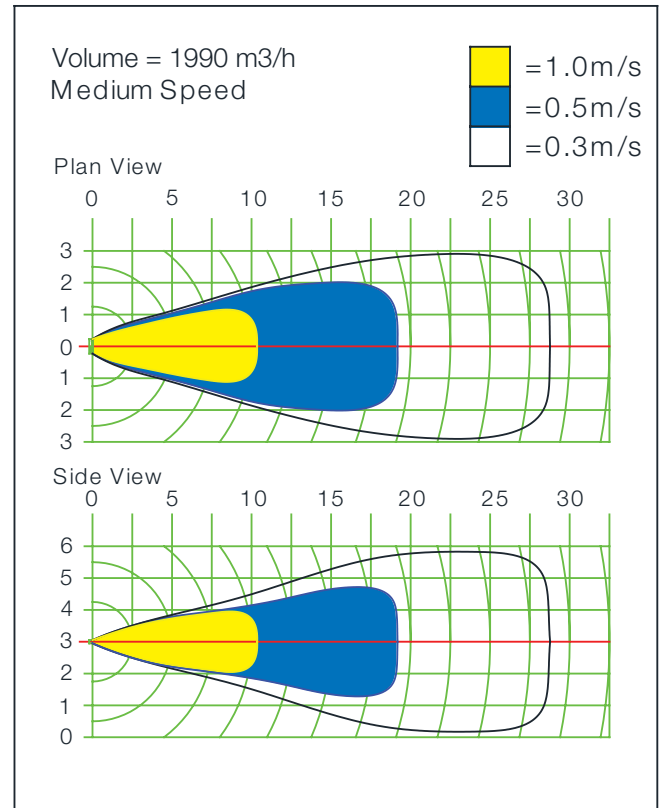
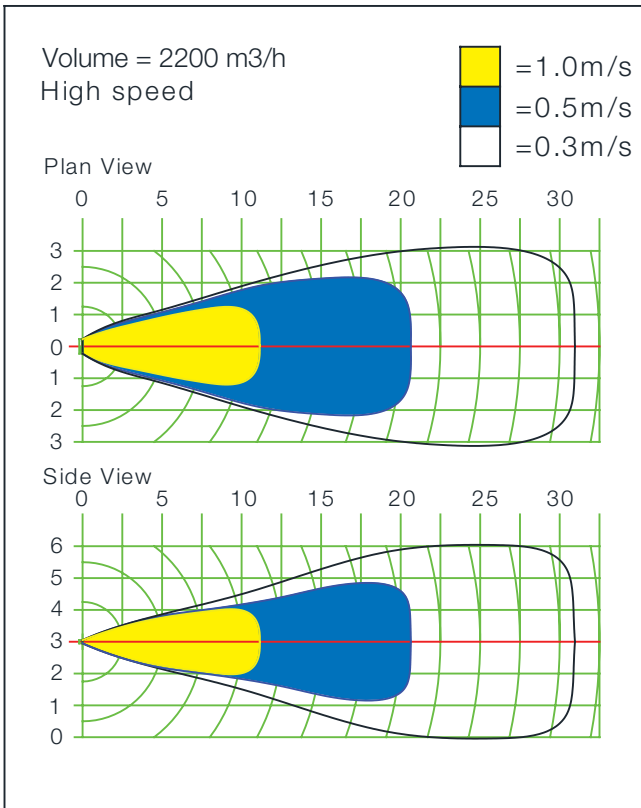

All scale in meter

Note: We reserve the right to alter measurements without notice in case of technical improvements

Air Velocity Profile (J11-20, J11-E-20, J11-E-30)

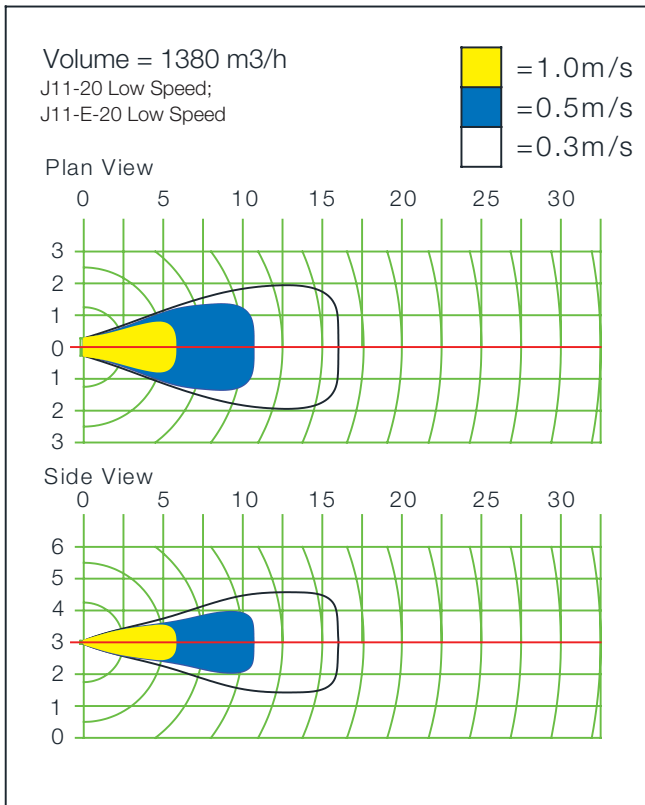
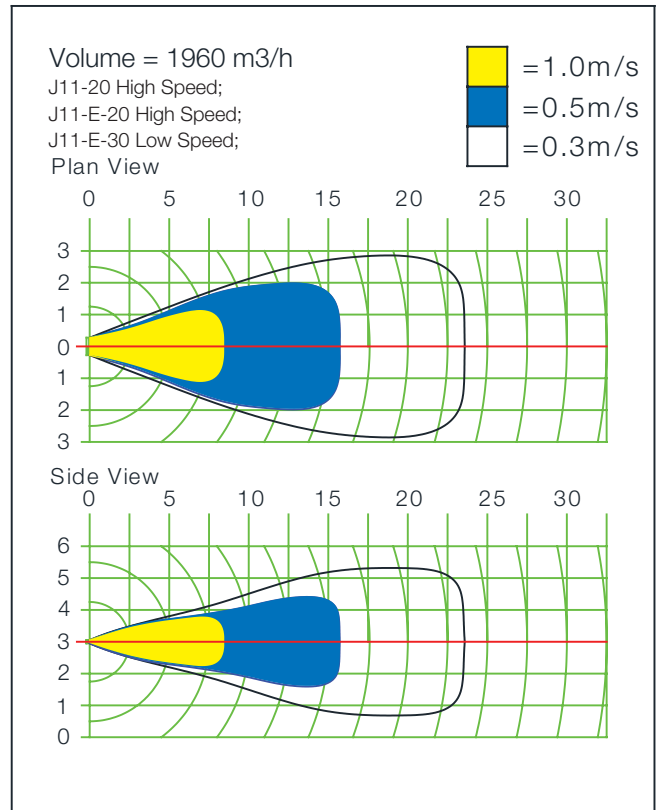
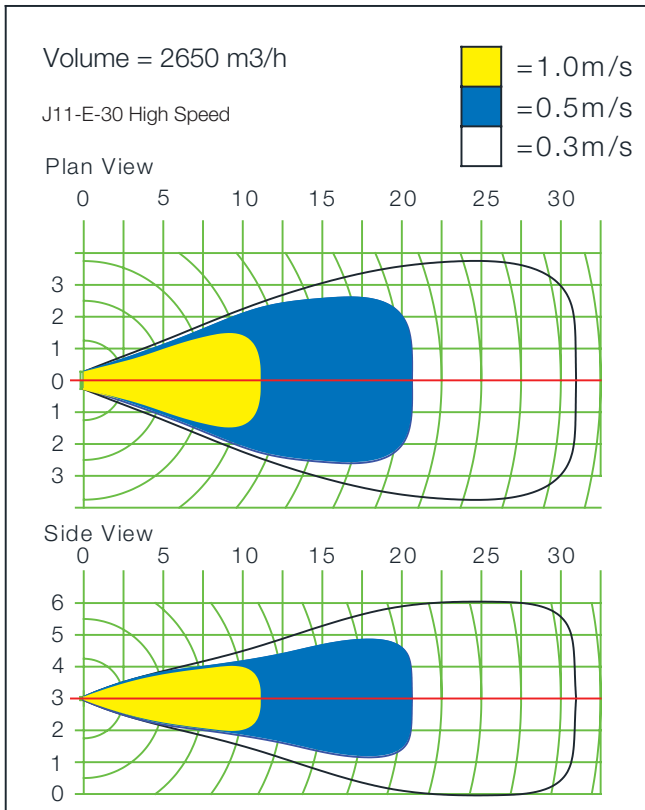

All scale in meter

Note: We reserve the right to alter measurements without notice in case of technical improvements

Air Velocity Profile (J15-20, J15-E-20, J15-E-30)

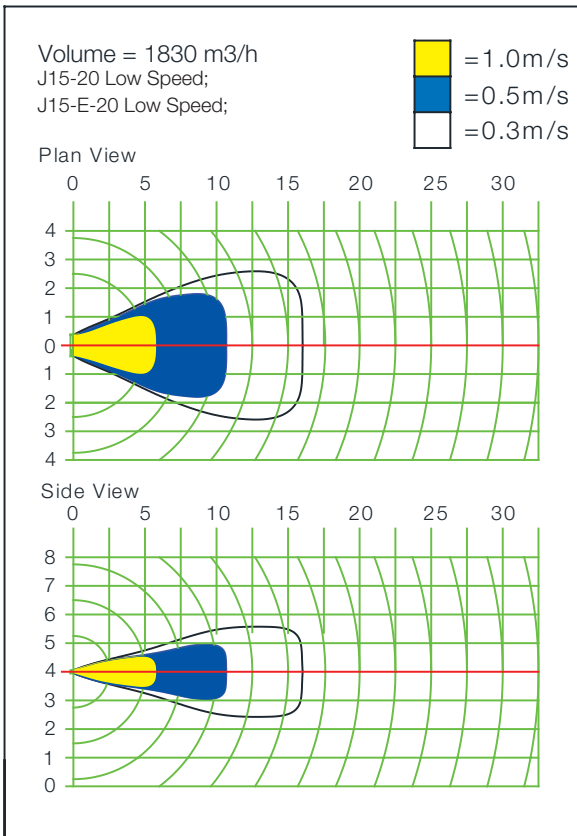
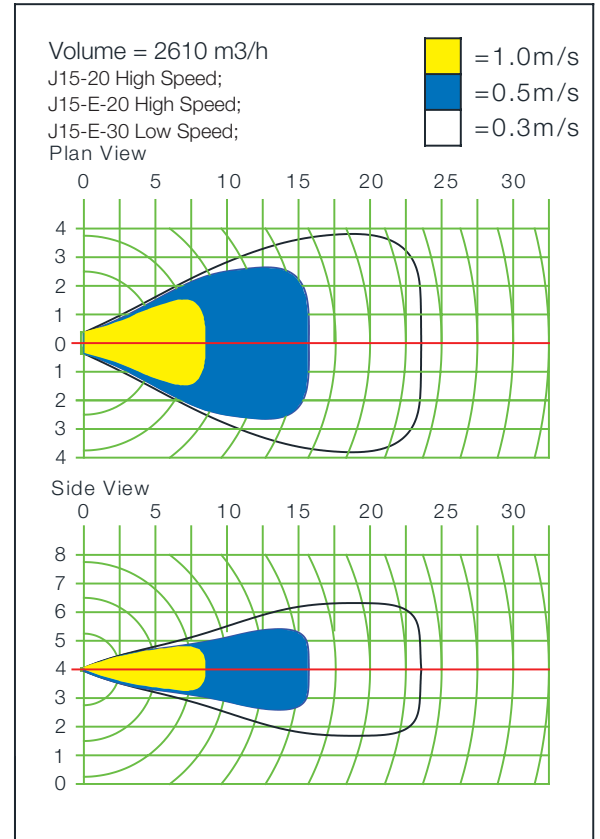
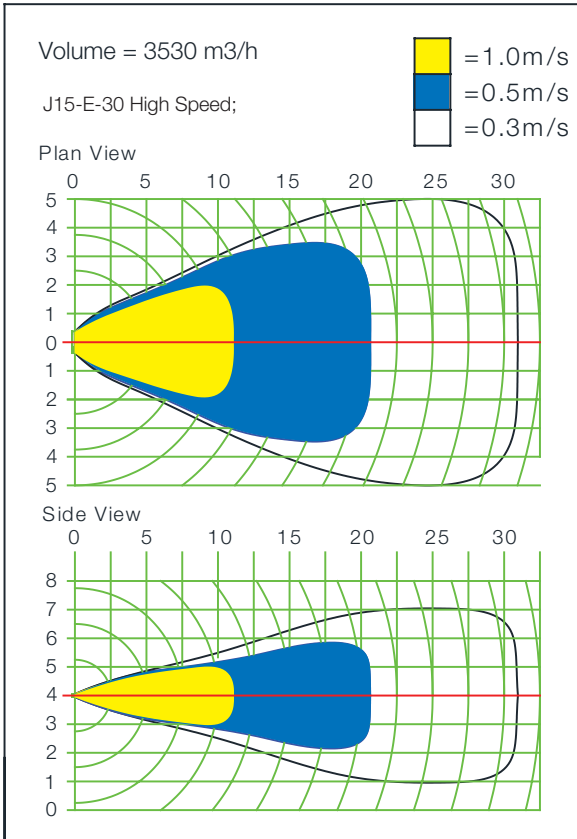

All scale in meter

Note: We reserve the right to alter measurements without notice in case of technical improvements

Sales Network

Deutschland

Wolter GmbH.
Maschinen-und Apparatebau KG.
DE-76316 Malsch
T +49 (0) 72 04 / 92 01 0
F +49 (0) 72 04 / 92 01 11
info@wolter.eu

Europe

Denmark:

L.ØLAND VENTILATION A/S
DK-2605 Brøndby
T +45 (0) 70 / 20 19 11
salg@airforce.dk

Netherlands:

DE WIT Ventilatoren BV
NL-3821 CG Amersfoort
T +31 (0) 33 / 76 00 240
info@dewitventilatoren.nl

Sweden:

Nordisk Ventilator AB
SE-142 50 Skogås
T +46 (0) 8 / 72 70 250
se@nordiskventilator.se

Switzerland:

Anson AG Zürich
CH-8055 Zürich
T +41 (0) 44 / 46 11 111
F +41 (0) 44 / 46 13 111
info@anson.ch

OZ Tech SA

CH-1122 Romanel-sur-Morges
T +41 (0) 76 / 41 11 572
info@oztech.ch

United Kingdom:

Wolter (UK) Ltd.
GB-Leicestershire LE65 1AL
T +44 (0) 15 30 / 41 24 73
info@wolteruk.com

Middle East

UAE, Saudi Arabia, Qatar, Lebanon:

Please contact Wolter head office

Wolter GmbH.

Maschinen-und Apparatebau KG.
DE-76316 Malsch
T +49 (0) 72 04 / 92 01 0
F +49 (0) 72 04 / 92 01 11
info@wolter.eu

Asia

China:

Guangdong Wolter Chemco Ventilation Ltd.
Boluo, Huizhou, Guangdong

Dongguan Wolter Chemco Ventilation Ltd.

Shipai, Dongguan, Guangdong
T +86 (0) 769 / 8655 7298
F +86 (0) 769 / 8655 7278
info@wolter.com.hk

Taizhou Wolter Ventilation Co. Ltd.

Hengjie, Luqiao District,
Taizhou, Zhejiang
T +86 (0) 576 / 26 22 666 (26 52 888)
F +86 (0) 576 / 26 56 830

China - Hong Kong, Macau:

Wolter Asia Ltd
Kowloon, Hong Kong
T +852 (0) 2456 0198
F +852 (0) 2456 0290
info@wolter.com.hk

China - Taiwan:

Waxlink International Co., Ltd.
8F-2 No.218 Roosevelt Rd.,
Sec.6, Taipei, Taiwan
T +886 (0) 2 / 8932 1196
F +886 (0) 2 / 8932 1197
waxlink@mail.waxlinktw.com

India:

Wolter Ventilators India Pvt. Ltd.
867 D, Block-A, Sushant Lok, Phase-I,
Gurgaon - 122009 (Haryana)
T +91 (0) 124 2577797, 4261001-3
sales@wolterindia.in

Korea:

Kaceco-Wolter
14-1, Dang-dong, Gunpo-shi,
Gyeonggi-do
T +(82) 0 31 / 4773 104
F +(82) 0 31 / 4773 132
wolter@kaceco.com
info@kaceco.com

Malaysia:

Vibrantech (M) Sdn Bhd.
47200 Petaling Jaya Selangor
T +603 (0) 7847 3500
F +603 (0) 7847 3380
sales@vibrantech-sb.com

Singapore:

Wolter Pte. Ltd.
SG-569738 Singapore
T +65 (0) 63 / 52 95 48
F +65 (0) 63 / 52 95 47
info@wolterfans.com.sg

Thailand:

Wolter Ventilation Co., Ltd.
Thamai Kratumban Samutsakorn
741 10 Thailand
T +66 (0) 84 555 2936
kongsakol@wolterfan.com

Australia

The Sydney Fan Company.
NSW 2147, Sydney, Australia
T +61 (0) 2 / 9624 4000
F +61 (0) 2 / 9624 4100
sales@thesydneyfancompany.com

Wolter GmbH Maschinen-und Apparatebau KG

Am Wasen 11
DE-76316 Malsch / Germany
T +49 (0) 72 04 / 92 01 0
F +49 (0) 72 04 / 92 01 11
www.wolter.eu
info@wolter.eu





Air In Motion

Reference: **A08.7**, V2024/November, Printed in November, 2024

Dongguan Wolter Chemco Ventilation Ltd. (Wolter Asia)

Shipai, Dongguan City, Guangdong Province, P.R.China

Tel. (+86)769 8655 7298, Fax (+86)769 8655 7278

www.wolterfans.com

info@wolterfans.com

