



Operating Instructions for

.....

Axial Fans

- Direct Drive & Belt Drive

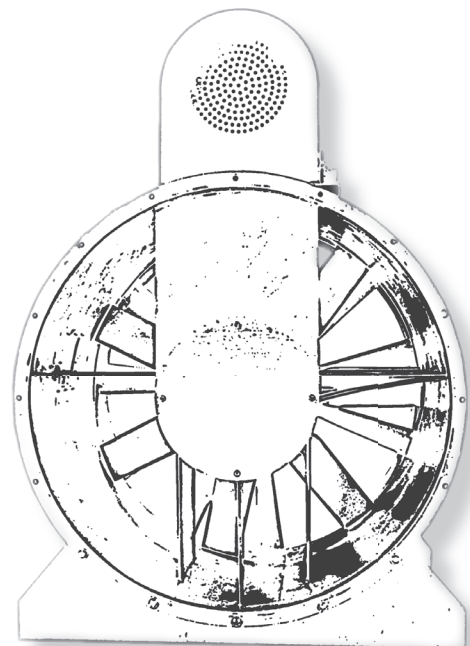
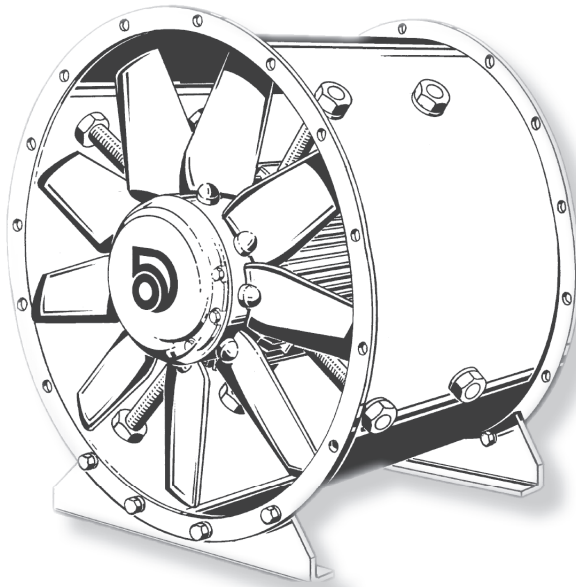

Guangdong Wolter Chemco Ventilation Ltd.

Jigongkeng Administrative Zone, Futian, Boluo, Huizhou, Guangdong, P.R.China. www.wolter.com.hk; info@wolter.com.hk

Dongguan Wolter Chemco Ventilation Ltd.

No.69, Miao Bian Wang Road, Shipai, Dongguan, Guangdong, P.R.China. Tel. +(86) 0769 8655 7298; Fax +(86) 0769 8655 7278

Contents

1	General safety notes.....	3
1.1	The Operator’s Duty of Care	3
1.2	Explanation of Safety Symbols.....	3
1.3	Fundamental safety measures.....	3
1.4	Particular kinds of hazards.....	4
2	Product description.....	4
2.1	Stipulated usage.....	4
2.2	Construction.....	5
2.3	Functional description	5
3	EC Declaration of Conformity.....	6
4	Transportation and Storage.....	7
4.1	Transportation.....	7
4.2	Storage.....	7
5	Assembly.....	7
5.1	Frequent errors which occur during assembly.....	8
5.1.1	Inflow.....	8
5.1.2	Outflow.....	9
5.1.3	Bends.....	9
5.1.4	Changes in cross-sectional area.....	9
5.1.5	Flexible connections.....	10
6	Initial Start up.....	10
6.1	Checks prior to initial start-up.....	10
6.2	Starting up the fan for the first time.....	11
6.3	Checks after initial start-up.....	11
7	Help with Malfunctions.....	12
7.1	Tabular overview of possible malfunctions and aids in eliminating those malfunctions.....	12
8	Maintenance.....	14
8.1	Servicing.....	14
8.2	Overhaul.....	15
8.2.1	Dismantling the rotor.....	15
8.2.2	Assembling the rotor.....	15
8.2.3	Maintenance of anti-friction bearings.....	15
8.2.4	Instructions on correct bearing replacement.....	17
8.2.5	Installation sketch.....	18
8.2.6	Installation types.....	20
8.3	Functional description and mounting instruction.....	40
8.4	Belt Drive (BD).....	41
8.5	Operation at higher temperatures(> 70 deg. C) / Smoke proof design.....	45
8.6	Electrical Motor and its connection.....	46
8.7	Vibration Monitoring.....	47
9	Commissioning checklist.....	48
10	Status - and maintenance checklist.....	49
11	Instructions regarding special types of dangers.....	50
11.1	Electrical energy.....	50
11.2	Gas, dust, steam, smoke.....	50
11.3	Hydraulics, pneumatics.....	51
11.4	Noise.....	51
11.5	Oils, grease and other chemical substances.....	51
11.6	Portable machines (Machines used at different locations).....	51

1 General safety notes

1.1 The operator's duty of care

The fans of the AXV and BXV series have been constructed and built whilst taking into account an analysis of the hazards involved, and after careful selection of the harmonised standards to be observed, as well as other further technical specifications. They thus correspond to the current level of technology and guarantee a high degree of safety.



In operational practice, however, this level of safety can only then be attained if all required measures are taken. It is incumbent upon the operator's duty of care to plan these measures and to monitor their execution.

In particular, the operator must ensure that

- the fan is only used as stipulated (cf. chapter, „Product Description“)
- the fan is only operated in a faultless and functional condition and that safety fittings, especially, are regularly examined with respect to their functionality
- the operating instructions are always maintained in a readable condition and are available at the fan's location of deployment in their entirety
- only sufficiently qualified and authorised personnel operate, maintain and repair the machine
- these members of personnel are familiar with the operating instructions and especially the safety notes contained therein
- no safety and warning signs fitted to the fan are removed, and that they are kept in a readable condition.

1.2 Explanation of the safety symbols used

The following symbols are used in these operating instructions. These symbols are, above all, intended to draw the reader's attention to the text contained in the adjacent safety note.

	Warning	This symbol indicates that dangers exist which are hazardous to life and health
	Mortal danger	Electrical hazard. Serious – and also fatal – injury can result if these notes are disregarded.
	Note	Indicates user tips and other useful advice.

1.3 Basic safety measures

Wolter axial fans are, at the moment of delivery, manufactured to the current level of technology.

Extensive materials, function and quality checks assure them of a high level of usefulness and long service life! Nevertheless, these machines can be dangerous if they are improperly used by untrained personnel or are used in a non-stipulated manner.

- Read these operating instructions carefully before putting the axial fans into operation!
- Only operate the fan in its enclosed state or with properly assembled protective anti-intrusion fittings, or with protective screens. (We can supply suitable, tested protective screens on request!)



- Assembly, electrical connection and maintenance may only be carried out by trained craftsmen!
- Only operate the fan in the manner stipulated and within the specified output limits (see rating plate) and with approved conveyed media!

1.4 Particular kinds of hazards

The fans of the AXV and BXV series are axial fans. In this respect, particular hazards are caused by the rotor and through the flow of air, which can, at times, be considerable. For this reason the following points are to be observed:

- Never reach into the rotor when it is rotating. Do not try to use your hand as a brake for the rotor during maintenance work.
- Loose clothing or light parts can be sucked in by the draught of air. That is why you should always wear tight-fitting clothing during maintenance work and during free-suction operation.
- Larger items (tools etc.) can obstruct or totally ruin the rotor. For this reason you should always fit a protective screen during free-suction or free-blowing operation.

2 Product description

2.1 Stipulated usage

Our axial fans have been specially developed for use in modern ventilation and air conditioning systems. The rotors are statically and dynamically balanced at the factory, and manufacture is subject to the strictest intermediate and end checks and is certified in accordance with DIN/EN/ISO 9001.

Conditions of use

The air should correspond to tender specifications, as the corresponding components are determined for this. If these are not listed in more detail, then the following applies:

The axial fans of the AXV and BXV series are suitable for the conveyance of

- clean air
- air which has little dust and grease content
- gases and vapours which are only slightly aggressive in nature
- media up to a maximum air density of 1.3 kg/m³
- flow volumes at temperatures ranging from - 30 °C to + 60 °C
- media up to a max. humidity of 95%

Conditions of fitting

- The fan must either be built into a ducting channel or have suction and outflow protection elements fitted to it.

The fans are not designated for any types of usage other than those cited here, and any such use shall be considered as improper usage!



In particular, we especially draw your attention to the following points. Non-compliance can either result in considerable material damage or personal injury, or that the demanded fan output values are not attained.

- The fan may not be operated without the necessary safety fittings. Should there be no ducting channel connected at one end, e.g. the suction end, then a protective screen must be fitted at that end in order to prevent access to rotating parts.
- In order to avoid any damage to the fan and specially to the rotor vanes, you must prevent the possibility of loose parts being sucked in by the fan or of other items being able to find their way into the fan.

- The fitting notes regarding intake and outlet flow conditions are to be observed.

2.2 Construction

The axial fan consists of the following main parts:

- (1) Ducting piece as fan housing
- (2) Rotor mounted onto the motor shaft
- (3) Motor stay in the form of struts or bracket
- (4) Electric motor

According to the particular use the fan is put to, the following parts may also be included:

- (5) An intake nozzle complete with suction protective screen for free-suction operation
- (6) An outflow protective screen for free-blow operation
- (7) Flexi-connectors are obtainable to prevent decoupling through vibration
- (8) Vibration dampers (spring or rubber vibration dampers according to the weight of the unit)
- (9) Counter flange
- (10) Fan switch-off facility
- (11) Assembly base supports

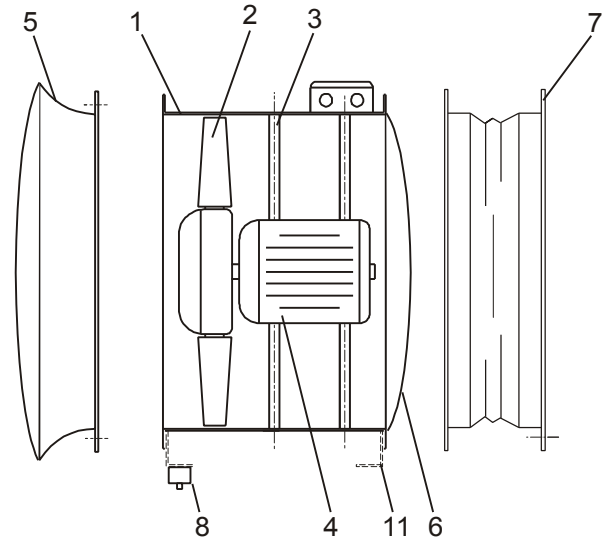

In normal circumstances the fan is built into a ducting system. It can, however, be integrated into a box in order to suppress noise, which is then built into the ducting system.

The rotors, made from plastic or aluminium, have fins which can be adjusted when the fan is not running. The fan's characteristic curve can be adapted the required operational point by this means (take note of the motor's loading specification!)

2.3 Functional description

The fan sucks air from the ducting on the suction side through the rotating rotor and conveys this air in the axial direction to the outflow side via the motor. The motor is positioned in the air flow and is cooled by the flow.

Control and regulation of the system is carried out by an external control unit. This does not form part of the fan itself. The corresponding operating instructions are to be consulted with regard to the control unit's operation. The fan itself requires no operation when it is running.

3 EC Declaration of Conformity

in accordance with Appendix II A of the EC Machinery Directive (89/392/EWG)

The manufacturer: **Guangdong Wolter Chemco Ventilation Ltd.**
 Jigongkeng Administrative Zone, Futian Town,
 Boluo, Huizhou City, Guangdong Province,
 P.R.China

hereby declares that the machine described in the following: **Fans of the AXV, BXV, RXV, AXG, AXV-F, AXV-GV.**

meets the health and safety requirements of the following EC Directives: **In accordance with Machinery Directive (98/37/EG), Appendix II A in accordance with the Low Voltage Directive (73/23/EWG)**

Harmonised standards applied:

DIN EN 60335-2-2	Safety of electrical equipment for household use and similar purposes; Part 2: Special requirements for dust and water suction machinery
DIN EN 60335-2-80	Safety of electrical equipment for household use and similar purposes; Part 2: Special requirements for fans
DIN VDE 0700-220	Safety of electrical equipment for household use and similar purposes; Fans and associated control units for use on ships
DIN EN 1037	Machine safety; Avoiding the unexpected start up of the machinery.
DIN EN 1088	Machine safety; Locking systems in combination with detachable protective fittings; Guiding principles for lay-out and selection
DIN EN 25136	Acoustics; Determining the irradiated noise output of fans in ducting. Ducting behaviour (ISO 5136:1990 and Technical Corrigendum 1:1993)
DIN EN 292-1	Machine safety; Basic terms, general guiding principles of lay-out; Part 1: Basic terminology, methodology
DIN EN 294	Machine safety; Safety distances for the prevention of upper limbs coming into the vicinity of danger areas
DIN EN 811	Machine safety; Safety distances for the prevention of lower limbs coming into the vicinity of danger areas
DIN EN ISO 11200	Acoustics; Noise irradiation of machines and appliances; Guidelines on the application of basic standards for establishing noise emission levels at the workplace and at other fixed locations (ISO 11200:1995)

Any changes in construction which have an effect on the technical data specified in the operating instructions and on the machinery's stipulated usage, i.e. those changes which essentially change the machine, shall invalidate this declaration of conformity!

Date: 15.06.2022



Nicholas Ang
 Vice President

4 Transportation and Storage

4.1 Transportation

Wolter fans are packed at the factory to suit the respectively agreed mode of transportation.

Transport the fan in its original packaging.

- Only use suitable means of transport, such as pallet trucks or fork-lift trucks.
- If the fan is to be transported by hand, ensure that supporting and carrying loads are kept within reasonable limits for the personnel involved.



The following special hazards must be taken into account when transporting the equipment:

- The transportation packaging does not prevent damage to the equipment through improper transportation. The fans must not be dropped or thrown.
- Sharp, protruding edges can lead to injury through cuts.
-  - Suspended loads can fall, which then constitutes a fatal hazard – stand well clear of suspended loads!
- Parts which have been stacked too high can collapse.
- If load-carrying devices other than those specified here are used, then this can lead to serious damage to the machine.
- A risk of fire exists due to the easily flammable nature of the packaging materials – do not use naked flames and do not smoke!
- Read the chapter, „General Safety Notes“.

4.2 Storage

- Store the fan in a dry, weather-protected location in its original packaging or protect it from the effects of dirt and the weather until final assembly. Cover open pallets with tarpaulin sheets and protect the fans from the effects of dirt and contaminants (e.g. swarf, stones, wire etc.)
- Avoid extremes of cold and heat.
- Avoid lengthy storage periods (a maximum of one year is recommended) and check that the motor bearing assembly is in good functional order prior to fitting.

5 Assembly



Assembly and electrical work is only to be carried out by trained and instructed craftsmen and in accordance with the respectively applicable regulations!



The following points are to be observed when assembling the fan:

- Secure the fan to the assembly base plates.
- The fans must not be deformed or twisted during fitting! Use spacing plates if the need arises
- The fitting position agreed in the lay-out is to be observed
- Only self-locking screws may be used for securing the outflow flange!



Attention: Make the electrical connection in accordance with the technical connection conditions and the relevant regulations!

- Make the electrical connection as per the enclosed terminal plan in the motor connection cabinet or terminal cabinet housing
- Feed in and seal the cable into the connection cabinet properly
- If present, connect the posistor / thermo-contact for motor protection, as otherwise the warranty lapses!



Before checking the direction of travel:

- Remove foreign bodies from the fan area
- Assemble contact protector, protective screen (see accessories), or box in fan
- Turn the rotor through a few revolutions by hand in order to test its ease of movement
- Check the direction of travel in accordance with the arrow on the housing by switching on and off very quickly
- If necessary, alter the direction of travel for AC motors by swapping 2 phases
- In the case of single-phase motors, reverse the direction of travel by swapping Z1 with Z2 (attention: the direction of current flow in the auxiliary winding also changes)

5.1 Common errors which occur during assembly

The following points must always be observed in order to achieve the desired operational level and to guarantee the fan's safe operation.

5.1.1 Inflow

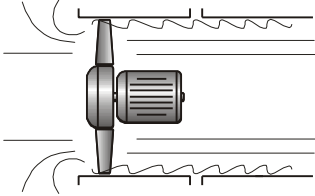
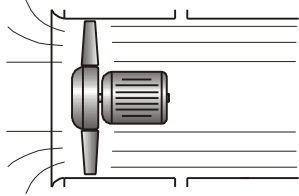
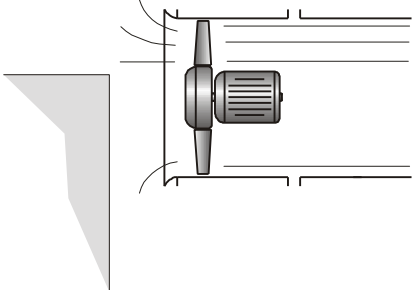
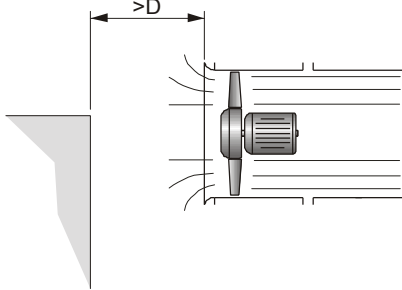
Incorrect	Correct
 <p>INCORRECT: No intake nozzle – Result: The vane edges are not in the air flow, the air output is reduced, noise output becomes greater. This can cause permanent damage to the rotor blades.</p>	 <p>RECOMMENDED: The intake nozzle enables an even flow to be achieved over the whole cross-sectional area.</p>
 <p>INCORRECT: The fan output is reduced if an obstacle is situated too close to the intake</p>	 <p>RECOMMENDED: The distance must be at least as great as the fan diameter</p>

5.1.2 Outflow

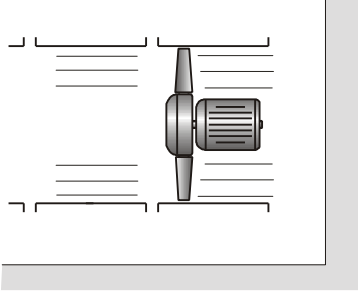
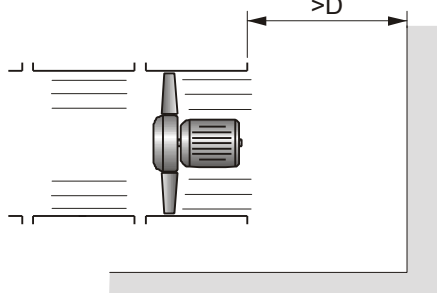
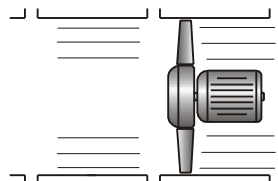
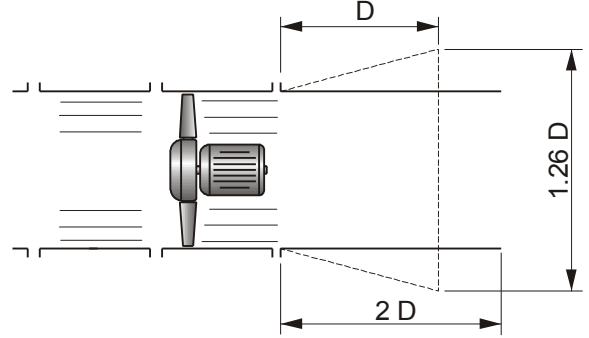
Incorrect	Correct
 <p>INCORRECT: Any blockage of the outflow must be prevented</p>	 <p>RECOMMENDED: The distance must at least be as great as the fan diameter</p>
 <p>INCORRECT: The outflow should not end at the same point as the fan.</p>	 <p>RECOMMENDED: An outflow passage having a length of $2xD$, or an outflow diffuser, as shown, both reduce outflow losses</p>

5.1.3 Bends

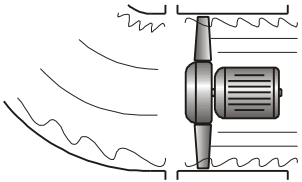
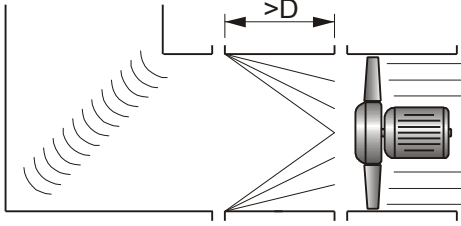
Incorrect	Correct
 <p>INCORRECT: Bends with a small radius of curvature reduce fan output and increase noise levels if fitted too close in front of the vane.</p>	 <p>RECOMMENDED: A quadratic channel corner with short guide vanes is preferred.</p>

5.1.4 Changes in cross-sectional area

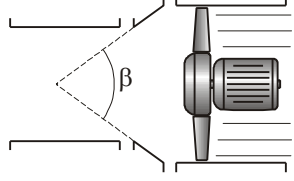
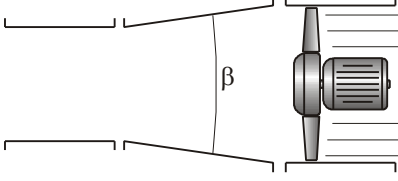
Incorrect	Correct
 <p>INCORRECT: Diffusers or nozzles having an angle greater than 30° should not be used.</p>	 <p>RECOMMENDED: If possible the angle should be less than 15°.</p>

5.1.5 Flexible connections

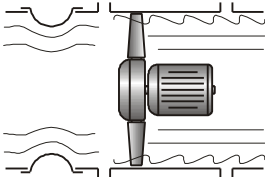
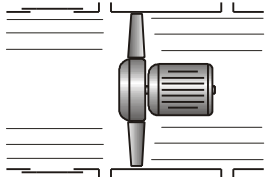
Incorrect	Correct
	
<p>INCORRECT: Loose, flexible connections in front of the fan obstruct the available cross-sectional area, fan output is reduced and noise levels increase.</p>	<p>RECOMMENDED: Flexible connections should be tensioned to such a point that they only permit the movement required for insulation.</p>

6 Initial Start-up

The following points are to be observed in order to avoid damage to the machinery or life-threatening injury during initial start-up:

- Only qualified personnel may carry out the machine’s initial start-up and this must take place in compliance with the safety notes.
- Prior to initial start-up, check that all tools and foreign bodies have been removed from the machine.
- Activate all safety devices and Emergency Stop switches prior to initial start-up.
- Check the motor’s direction of travel prior to initial start-up.
- Read the chapter, "General Safety Notes ".

6.1 Checks prior to initial start-up

Proceed with the fan’s initial start-up in the following sequence:

- Check that the mechanical assembly has been carried out properly
- Remove foreign bodies located in the suction and outflow areas and in the fan space
- 
 - Check that the electrical installation has been completed in accordance with regulations
 - Does the mains voltage match the motor voltage specified on the rating plate?
 - Is the switchgear used suitable for the motor both with respect to the switching functions to be carried out and also to the switching conditions and switched output of the motor?
 - Is the motor protection system set correctly with regard to the motor’s nominal current? The setting must be carried out in accordance with the corresponding details contained on the motor output plate.
 - Has the motor been connected correctly in accordance with the wiring diagram?
The connection schematic supplied by the motor suppliers applies for the connection of the motor. The special connection regulations are to be observed for explosion-protected models.

 **Accident prevention**

- Protective anti-intrusion fittings, protective screens (see accessories) mounted, fan boxed in or assembled out of reach.
- If the fan is assembled for free-suction, the suction aperture must be covered by a protective screen. This is the only way that the accident prevention regulation governing protection from contact can be deemed to have been met.

6.2 Starting up the fan for the first time

Only put the fan into operation after it has been assembled in accordance with the regulations!

- Put the fan into operation.
- Monitor its correct function (quiet running, vibration, imbalance, power consumption, controllability)



Should the required output (volume flow or pressure increase) not be achieved by the fan, e.g. through unforeseen changes in the installation system, the rotor fins can be adjusted up to the maximum fin settings specified both on the rating plate and in the technical documentation. The power consumption must be re-measured in order to avoid any possible motor overload.

The thermo-protection system may be activated if the motor power consumption is too high!



- Check the bearing temperature after a lengthy period of operation

Always keep suction openings clear! Check protective screens or protective anti-intrusion fittings for dirt, and clean if necessary!

6.3 Checks after initial start-up

Check the mechanical connections after initial start-up, especially the joints at the fan.

7 Help with Malfunctions

The following points must be observed in order to avoid damage to the machinery or life-threatening injury when eliminating machine malfunctions:

- Only eliminate any malfunction if you have the specified qualifications necessary for the task.
- First of all ensure that the machine cannot be switched on inadvertently, by locking the equipment's off switch or control cabinet by means of a padlock.
- Secure the hazardous area with respect to moving machine parts.
- Read the chapter, "General Safety Notes".

7.1 Tabular overview of possible malfunctions and aids in eliminating those malfunctions

Symptom	Cause	Elimination
Motor or motor control system switches off	Motor too hot, thermo-contact activates.	Allow the motor to cool off. Depending upon the control equipment in use, the fan will either start itself up or will have to be re-started again. Check whether: <ul style="list-style-type: none"> - The conveyed medium is too hot - All phases are evenly loaded and connected - Operating point does not match the lay-out - Rotor blocked
Air output incorrect	Incorrect direction of travel of the fan	Change the direction of travel (see electrical assembly)
	Fan assembled incorrectly	Either the rotor is incorrectly mounted on the motor shaft or the whole fan has been incorrectly fitted into the installation. Switch off the fan. Correct the incorrect assembly (rotor or complete fan).
	Rotor blocked	Switch off the fan. Remove the blockage. Ensure that the accident prevention regulations are observed in the process.
	Rotor defective	Switch off the fan. Dismantle the rotor and fit a new one.
	Lay-out does not match installation resistance	Clean or replace filters if dirty; In the event of an erroneous lay-out, the fan's output can be altered by changing the vane angle within limits. In this case the shaft output must be checked for the required vane, so that the motor is not overloaded. The rotor should be re-balanced after any alteration to the vane angle.
Fan is labouring under load, air flow is periodically interrupted	Fan is operating within an unfavourable characteristic curve range	If possible, reduce the installation resistance. If this laboured operation of the fan continues over a prolonged period, the rotor will be ruined!

Problem	Probable causes	Measure	Elimination
Too less volume flow	False direction of rotation Pressure higher than specified Rotational speed is too less Ducts are blocked Impeller is dirty	Shutdown Consult & shutdown Consult & shutdown Shutdown Shutdown	Check the motor connection Check the construction Adjust the rotational speed Clean the cables Clean the impeller
Very low pressure	False direction of rotation Volume flow is higher than spec. Density is lower than specified Rotational speed is too less Leakage in the fan Leakage in the system	Shutdown Consult & shutdown Consult & shutdown Consult & shutdown Shutdown Shutdown	Check the motor connection Check the construction Check the construction Adjust the rotational speed Change sealing Change sealing
Very high power	False direction of rotation	Consult & shutdown	Check the motor connection
Consumption	Volume flow is higher than spec. Pressure is lower than specified Density is higher than specified Rotational speed is high	Consult & shutdown Consult & shutdown Consult & shutdown Shutdown	Check the construction Check the construction Check the construction Adjust the rotational speed
Abnormal noises	Impeller grazes Defective sealing Contaminants in the casing Bearing damages Loose clamp screws	Shutdown Shutdown Shutdown Shutdown Shutdown	Check the Impeller/gap Change the sealing Eliminate contaminants Check for damages Repair Change the bearing Re-tighten the screws
Vibrations	Imbalance False direction of rotation Equipment defect Very high rotational speed Bearing damages Turbulences in the System Turbulences in the fan Loose clamp screws	Shutdown Shutdown Shutdown Shutdown Shutdown Consult & shutdown Consult & shutdown Shutdown	Clean the impeller, balancing Check the motor connection Align Check the rotational speed Change the bearing Check the air duct in the System Check the design/execution Re-tighten the screws
Rotational speed is too low	Slacking of the belt drive False transmission Motor overloaded	Consult & shutdown Consult & shutdown Shutdown	Tighten the belt or change Adjust the transmission Check the design
High bearing temperature	Too much grease/oil in the bearing Wrong grease/oil in the bearing Damaged bearings Very high temperature of the environment	Shutdown Shutdown Shutdown Consult & shutdown	Adjust the grease/oil quantity Change the grease/oil brands Change the bearing Cool down
Gas Odor	Defect of the shaft seal Defect of the casing seal Defect of the cable seal Crack in the casing or cables	Shutdown Shutdown Shutdown Shutdown	Change the shaft seal Change the seals Change the seals Repair

8 Maintenance

The following safety notes must be observed when maintaining the machine – life-threatening injuries to personnel, damage to the machine and other material damage, as well as environmental damage, will be avoided in this way.

- Cleaning, lubrication and maintenance work may only be carried out by authorised operating personnel – operating instructions are to be observed.
- Repair work may only be carried out by authorised craftsmen – accident prevention regulations are to be observed.
- Secure the operational area over a large area prior to the commencement of maintenance work.
- The specified sequence of the working stages is to be observed exactly.
- All work on the machine's electrical equipment may only basically be carried out by trained electricians.
- Self-locking screws and nuts are always to be renewed.
- All specified screw torque settings are to be observed precisely.
- Read the chapter, "General Safety Notes ".

8.1 Servicing

The rotor and housing are subject to natural wear and tear through the action of dust, acidic and corrosive vapours, as well as the gases which are mixed into the conveyed flow. The type and concentration of the dust, as well as the gases and vapours, can lead to deposits, abrasion and corrosion at the rotor and housing.

The materials can be attacked so much by this natural wear and tear that they can no longer stand up to the demands made of them. Deposits on the rotor, which have never been evenly distributed, lead to an imbalanced state and thus to noisy running, which in turn can result in damage to the motor bearing. Deposits in the housing lead to a narrowing of the available cross-sectional area or to a roughening of the housing panels and can thus have an unfavourable effect on the fan's output data. Should the checks, the regularity of which depend on the conveyed media and other operating conditions which differ in each individual case, only reveal slight wear and tear, then the individual parts can be cleaned in good time, or replaced if necessary.

Prior to all servicing work:

- Bring the fan to a halt in the prescribed manner and completely isolate the fan from the mains supply!
- Wait until the rotor has come to a halt!
- Ensure that the machine cannot be switched on again!
- Clean the fan
- Clean the suction apertures
- Clean the rotor (if necessary dismantle the protective anti-intrusion fitting)



Only use cleaning agents generally available through the trade and in compliance with the prescribed safety measures. Do not use scratching or scraping tools (protective surface coating will be ruined)

- Do not overload the motor!
- Do not bend the rotor or vanes!
- Assemble the protective anti-intrusion fitting

General checks

- Too much bearing play?
- Lubricant leaking from the bearings?
- Surface protective coating damaged?
- (Attention: Conveyed medium too aggressive!?)
- Unusual noises during operation
- Fan output still sufficient for possibly extended or shortened ducting system?

8.2 Overhaul

Prior to all overhaul work:

- Bring the fan to a halt in the prescribed manner and completely isolate the fan from the mains supply!
- Wait for the rotor to come to a halt!
- Ensure that the machine cannot be switched on again!

Only use spare parts which have been tested and approved by us!

Bushes		Torque	
Type	Drilling	Tightness	
	[mm]	[Nm]	
1008	12, 19, 24	6	2 threaded studs
1108	19, 24, 28	1/4" sw 3	
1210	16, 19	20 3/8" sw 5	
1215	24, 32		
1310	14, 25, 35		
1610	19, 24		
1615	38, 42		
2012	24, 38, 50	32 7/16" sw 6	
2517	38, 48, 60	49 1/2" sw 6	

Table 1 Torque settings for taper hubs

8.2.1 Dismantling the rotor

- Remove hub cover.
- Slacken off securing screw (Allen key), completely undo one grub screw and slacken off the tension cone using the forcing drilling.
- Pull off the rotor from the motor shaft (possibly using a puller tool)

8.2.2 Assembling the rotor

- Push the rotor onto the motor shaft
- Tighten both grub screws evenly, whilst observing the torque settings given in the adjacent table.
- Fit the hub cover

Screw	M 4	M 5	M 6	M 8	M 10	M 12	M 16	M 20
Torque setting	3.7	7.5	12	31	60	108	265	510
+0% / -10%	Nm	Nm	Nm	Nm	Nm	Nm	Nm	Nm

Table 2 Torque settings for screws

8.2.3 Maintenance of anti-friction bearings

8.2.3.1 Fan bearing service interval / Frequency of re-lubrication:

The roller bearings of the standard AC motors are basically equipped with a permanently sealed lubrication system consisting of a high-quality, temperature-resistant, lithium-based roller bearing grease (melting point approximately 160°C). The amount of lubricant supplied to the bearing by the motor manufacturer is sufficient for 10,000 to 20,000 operating hours.

The life of grease varies greatly as a result of types of model, revolution speed, temperature, operational conditions etc. It is, therefore, impossible to be precise about replenishment intervals. However, for normal direct coupling transmission, the periods shown as *Table 4* may be used as a guide.

Remarks:

- Please refer to the lubrication nameplate, if attached to the motor.
- For bearing numbers outside the range of *Table 4*, please contact Dongguan Wolter (Wolter Asia) at info@wolter.com.hk
- If the periods referred to in *Table 4* for drive-end bearing and opposite drive-end are different, for the convenience of maintenance operation, please take the shorter one the required grease replenishment period of these bearings.

8.2.3.2 Kind of grease

a. Standard Class B & F motor

MULTEMP SRL, Shell ALVANIA R3 or Polyrex EM will be used for all models with open bearings. Please check and follow lubrication nameplate for any special grease used in bearings. Please use identical grease or its equivalents when maintaining motor.

b. High temperature Class H motor

Mobil Polyrex EM, Exxon Polyrex EM will be used for all models with open bearings. Please check and follow lubrication nameplate for any special grease used in bearings. Please use identical grease or its equivalents when maintaining motor.



Do not mix different kinds of grease.

Mixing grease with different type of thickeners may destroy its composition and physical properties. Even if the thickeners are of the same type, possible differences in the additive may cause detrimental effects.

8.2.3.3 Grease quantity

The amount of grease per replenishment depends on the type, size and construction of the bearings. The maximum amount of replenishment for each bearing is shown in *Table 5*.

8.2.3.4 Re-greasing



If re-lubrication is to be performed when the motor is running, stay clear of rotating parts.

It is advisable to re-grease when the motor is running to allow the new grease to be evenly distributed inside the bearing.

Before re-greasing, the inlet fitting should be thoroughly cleaned to prevent any accumulated dirt from being carried into the bearing with the new grease. The outlet of grease drainage should be opened to allow the proper venting of old grease.

Use a grease gun to pump grease through grease nipple into the bearings. After re-greasing, operate the motor for 10-30 minutes to allow any excess grease to vent out.

Bearing Number		600 [1/min]	720 [1/min]	750 [1/min]	900 [1/min]	1000 [1/min]	1200 [1/min]	1500 [1/min]	1800 [1/min]	3000 [1/min]	3600 [1/min]	
62XX	10											
	11											
	12									2000 Hrs		
	13											
	14									1000 Hrs		
	15											
	16									720 Hrs		
	17								2000 Hrs			
	18											
	19											
63XX	20											
	22											
72XX	24											
	26											
73XX	28											
	30											
	32									500 Hrs		
	34											
	36											
	38											

Table 4 Frequency of re-lubrication

Bearing		Amount of replenishment	Bearing		Amount of replenishment		
Number		[g]	Number		[g]		
62XX	6210	30	63XX	6310	40		
	6211	30		6311	40		
	6212	40		6312	60		
	6213	50		6313	80		
	6214	50		6314	80		
	6215	60		6315	100		
	6216	60		6316	100		
	6217	80		6317	120		
	6218	80		6318	120		
	6220	100		6320	160		
	6222	120		6322	220		
	72XX	6224		120	73XX	6324	270
		6226		140		6326	300
		6228		160		6328	400
		6230		180		6330	450
		6232		200		6332	500
		6234		250		6334	600
6236		300	6336	700			
6238		350	6338	800			
6240	400	6340	900				
6244	450	6344	900				
6248	500	6348	900				

Table 5 The maximum amount of replenishment

* Fill new grease until it overflows and the old grease is entirely replaced.

8.2.3.5 Oil re-lubrication (For oil lubrication types only)

Maintain proper lubrication by checking the oil level periodically and adding oil when necessary. Because of the initial clearing action of the bearing and the expansion of the oil as it comes up to operating temperature, the oil level will be higher after the motor has been in operation for a while than it is with the motor at standstill.

Overfilling should be avoided not only because of the possibility that expansion may force the oil over the oil sleeve and on to the rotor, but also because too high an operating oil level prevents the bearing from clearing itself of excess oil. The resultant churning can cause extra loss, high temperatures, and oxidized oil. If, during operation, the oil level goes above the maximum shown on the sight gauge, drain enough oil to bring the level back within the recommended operating range. **Do not permit the operating level to fall below the minimum shown on the gauge.**



Should it ever become necessary to add excessive amount of make-up oil, investigate immediately for oil leaks.

Change the oil at regular intervals. The time between oil changes depends upon the severity of operating conditions and, hence, must be determined by the motor user. Two or three changes a year is typical, but special conditions, such as high ambient temperature, may require more frequent changes. Avoid operating the motor with oxidized oil.

Use only good grade, oxidation-corrosion-inhibited turbine oils produced by reputable oil companies.

8.2.4 Instructions on correct bearing replacement

Only allow work on the electric motor to be carried out by a craftsman or by a suitable motor winding workshop.

8.2.5 Installation sketch

A) Horizontal Arrangement

The length of the foundation embedded steel sheet is $(L + 100)$ or more, width is $((B2 - B1)/2 + 20)$ or more.

Fan with single connecting ducts

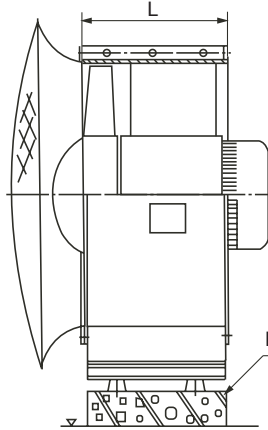

Embedded steel sheet

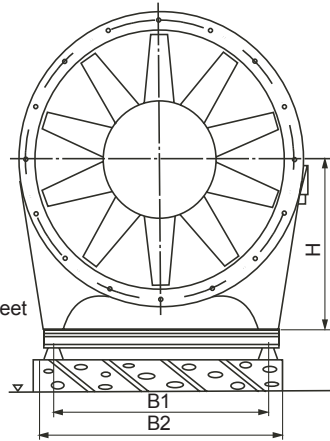

Fan with dual connecting ducts

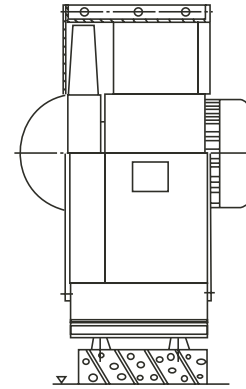

B) Vertical Arrangement

Circular Platform Opening

Fan with single connecting ducts

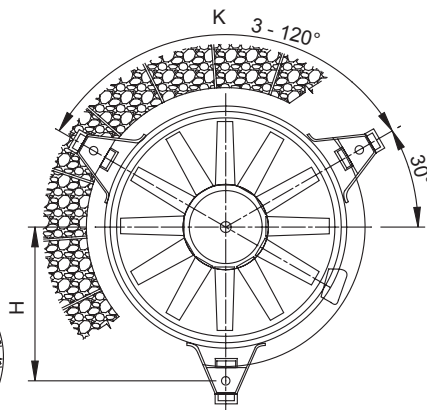
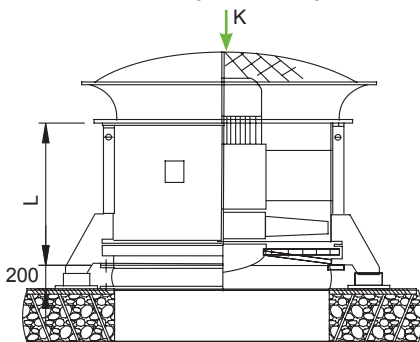

Fan with dual connecting ducts

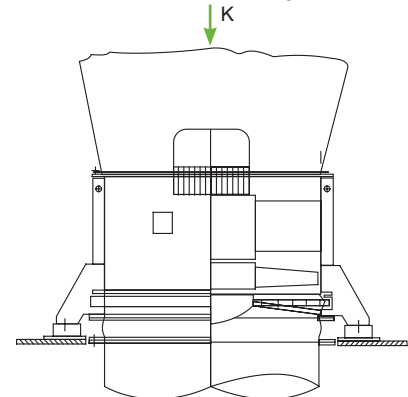

Square Platform Opening

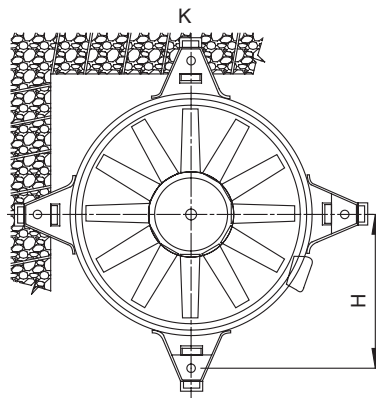
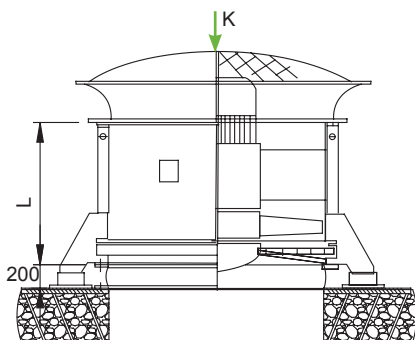

Fan with dual connecting ducts

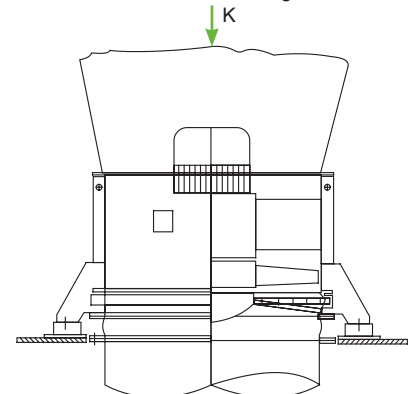

Size	1250	1400	1600	1800	2000	2200	2400	2500	2600	2800	3150
H (mm)	840	965	1065	1160	1260	1410	1510	1580	1650	1750	1930

C) Hanging Arrangement

For fans with motor power exceeding 75 kW, hanging arrangements are not advisable.

h value shall be determined according to the layout of the air duct in the ventilation system, referring to the installation sketch.

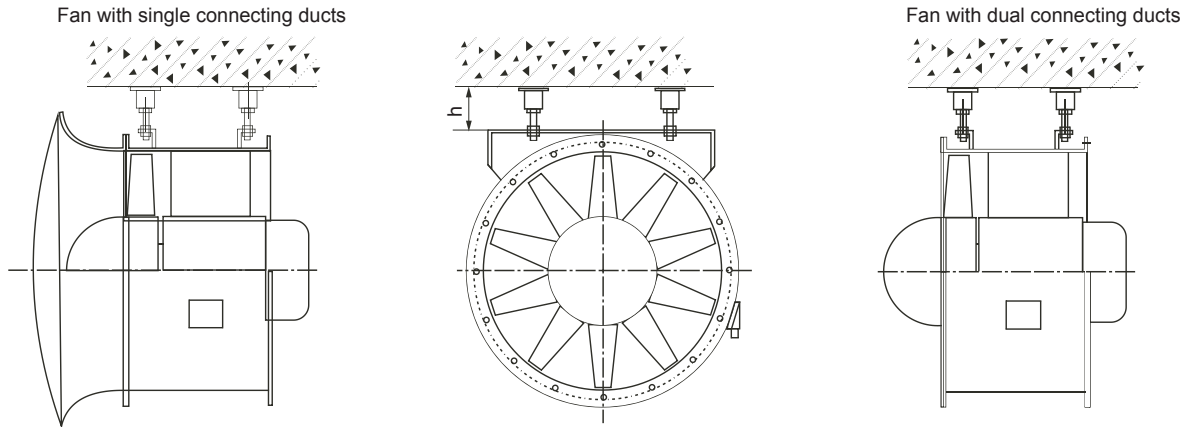

D) Wall Arrangement

For the wall arrangement, the fan is connecting to single duct or dual ducts.

For fans with motor power exceeding 22 kW, Wall mounting arrangements are not advisable.

The length of the plate is more than $(L + 100)$, width of that is more than $(B + 20)$.

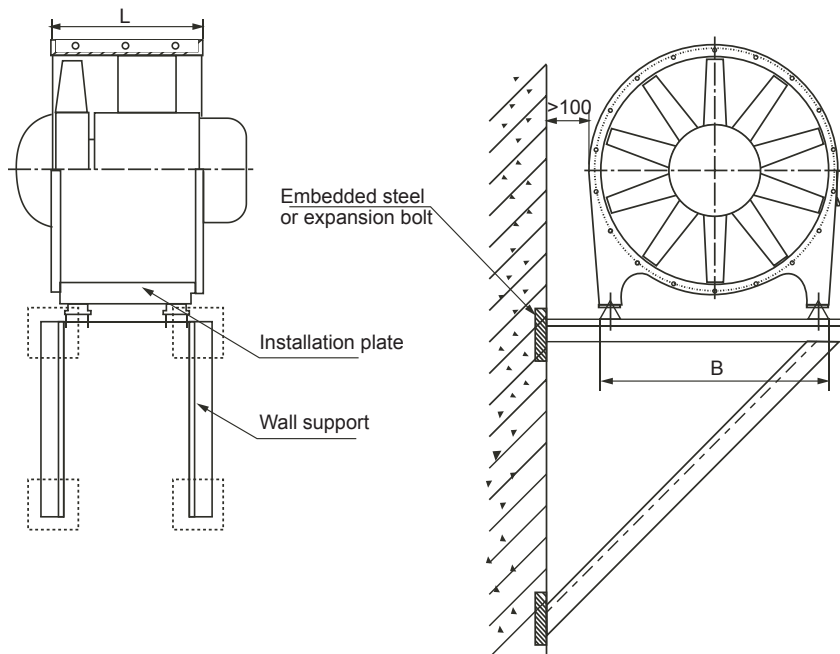

8.2.6 Installation types

Remarks:
 Dimensions are in mm and approximate only and subjected to changes without prior notice.
 Drawing for reference only. Not for QC / Manufacturing purposes.

Floor Mounting Type A Installation

Model Size	OD	Length	Total Approx Weight(kg)	Floor Mounted	BN
AXV 315	398	350	31~37	A/B	M12
AXV 355	438	350	33~39	A/B	M12
AXV 400	484	400	46~52	A/B	M12
AXV 450	534	400	62~67	A/B	M12
AXV 500	584	400	67~73	A/B	M12

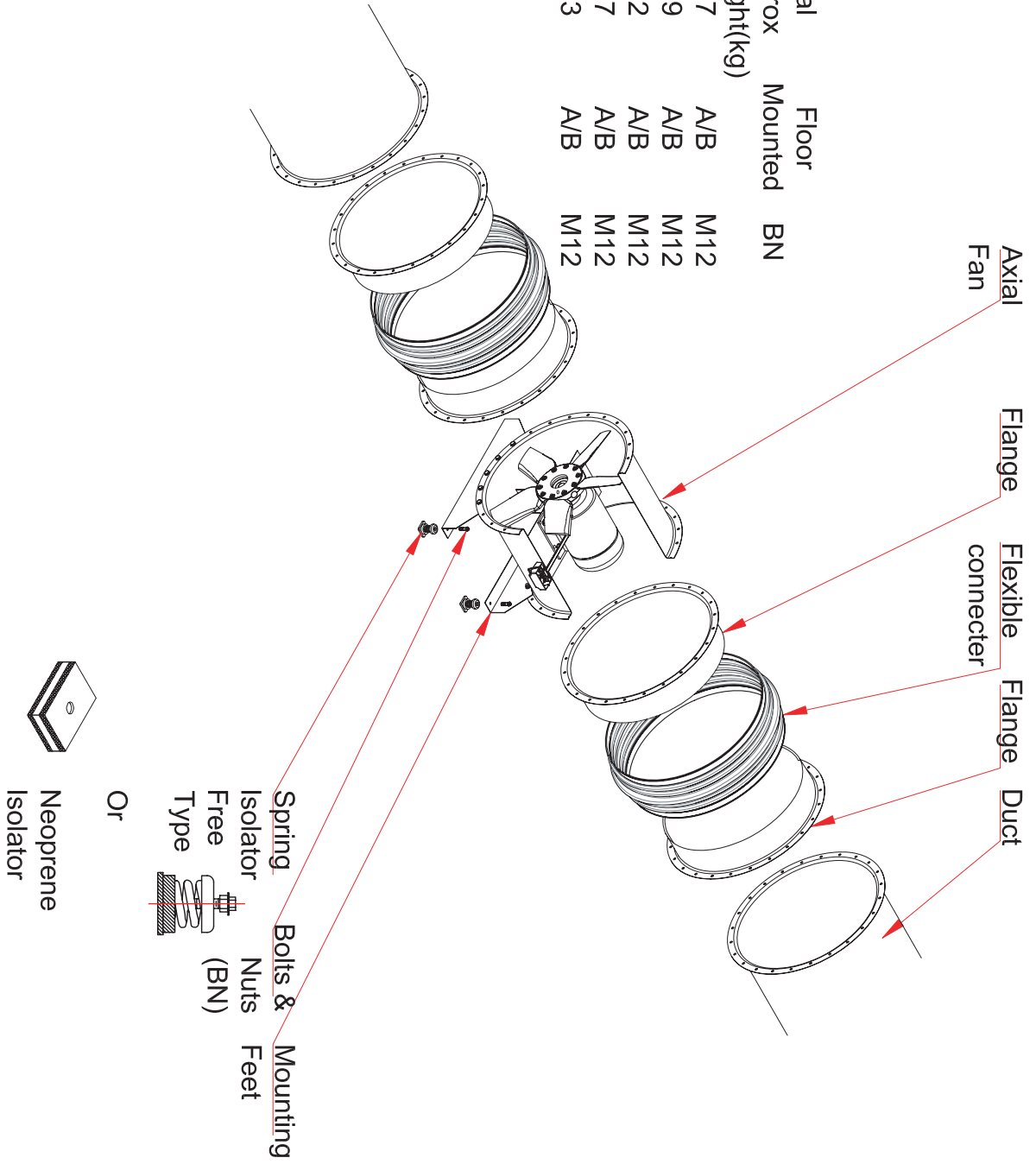

Floor Mounting Type B Installation

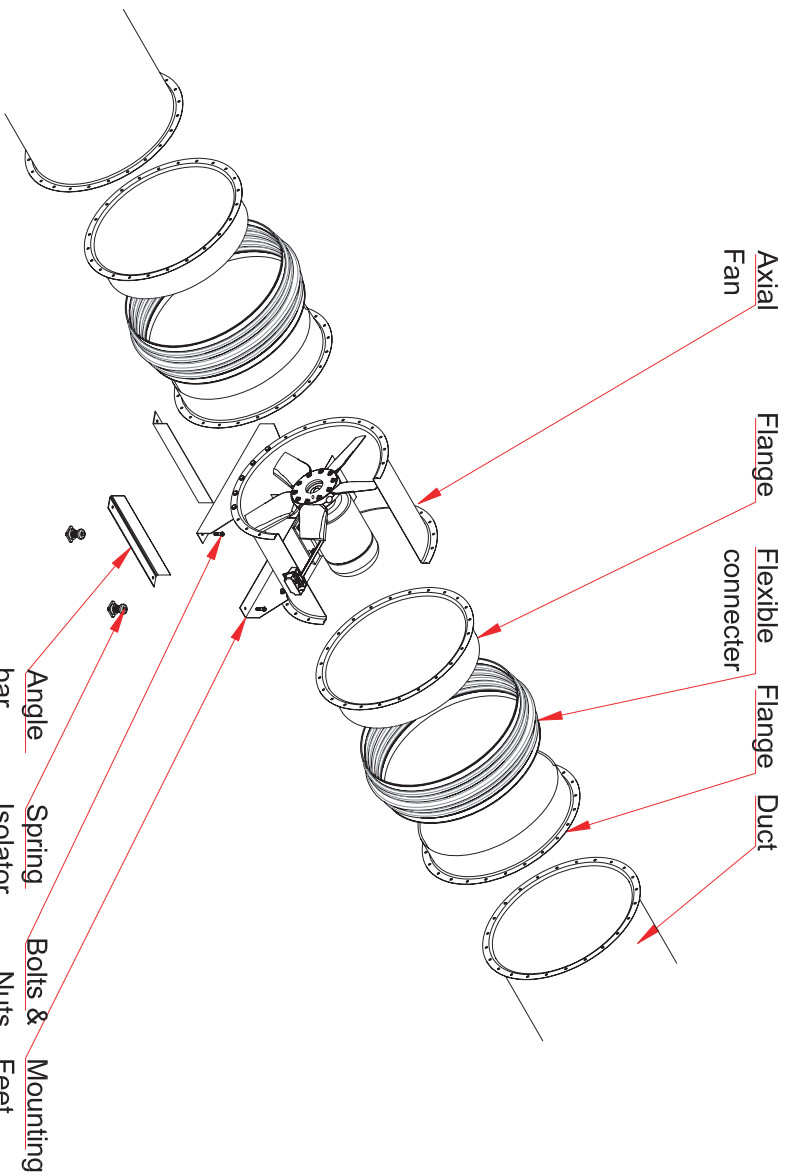

Model Size	OD	Length	Total Approx Weight(kg)	Floor Mounted	BN	Angle bar
AXV 315	398	350	31~37	A/B	M12	50x50x4
AXV 355	438	350	33~39	A/B	M12	50x50x4
AXV 400	484	400	46~52	A/B	M12	50x50x4
AXV 450	534	400	62~67	A/B	M12	50x50x4
AXV 500	584	400	67~73	A/B	M12	50x50x4
AXV 560	664	400	189~212	B/C	M16	50x50x4
AXV 630	734	400	199~224	B/C	M16	50x50x4
AXV 710	814	400	193~220	B/C	M16	50x50x4

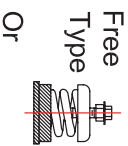

Remarks:
 Dimensions are in mm and approximate only and subjected to changes without prior notice.
 Drawing for reference only. Not for QC / Manufacturing purposes.

Floor Mounting Type C1 Installation

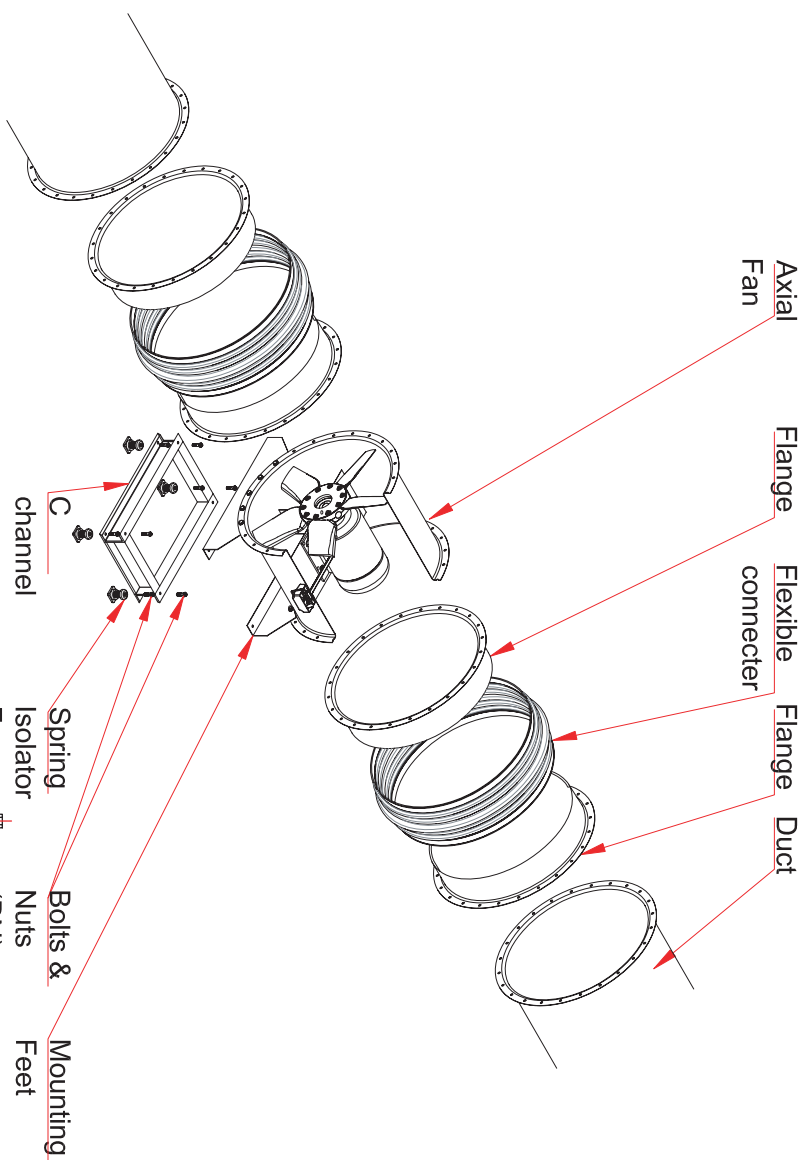

Model Size	OD	Length	Weight(kg)	Total Floor Mounted	BN	C channel
AXV 560	664	400	189~212	B/C	M16	100x48x5.3
AXV 630	734	400	199~224	B/C	M16	100x48x5.3
AXV 710	814	400	193~220	B/C	M16	100x48x5.3
AXV 800	904	400	220~256	C/D	M16	140x60x8.0
AXV 900	1004	530	281~315	C/D	M16	140x60x8.0
AXV 1000	1105	530	357~419	C/D	M16	140x60x8.0
AXV 1120	1245	816	501~564	C/D	M16	140x60x8.0
AXV 1250	1370	816	585~652	C/D	M16	140x60x8.0

Remarks:

Dimensions are in mm and approximate only and subjected to changes without prior notice. Drawing for reference only. Not for QC / Manufacturing purposes.

Floor Mounting Type C2 Installation

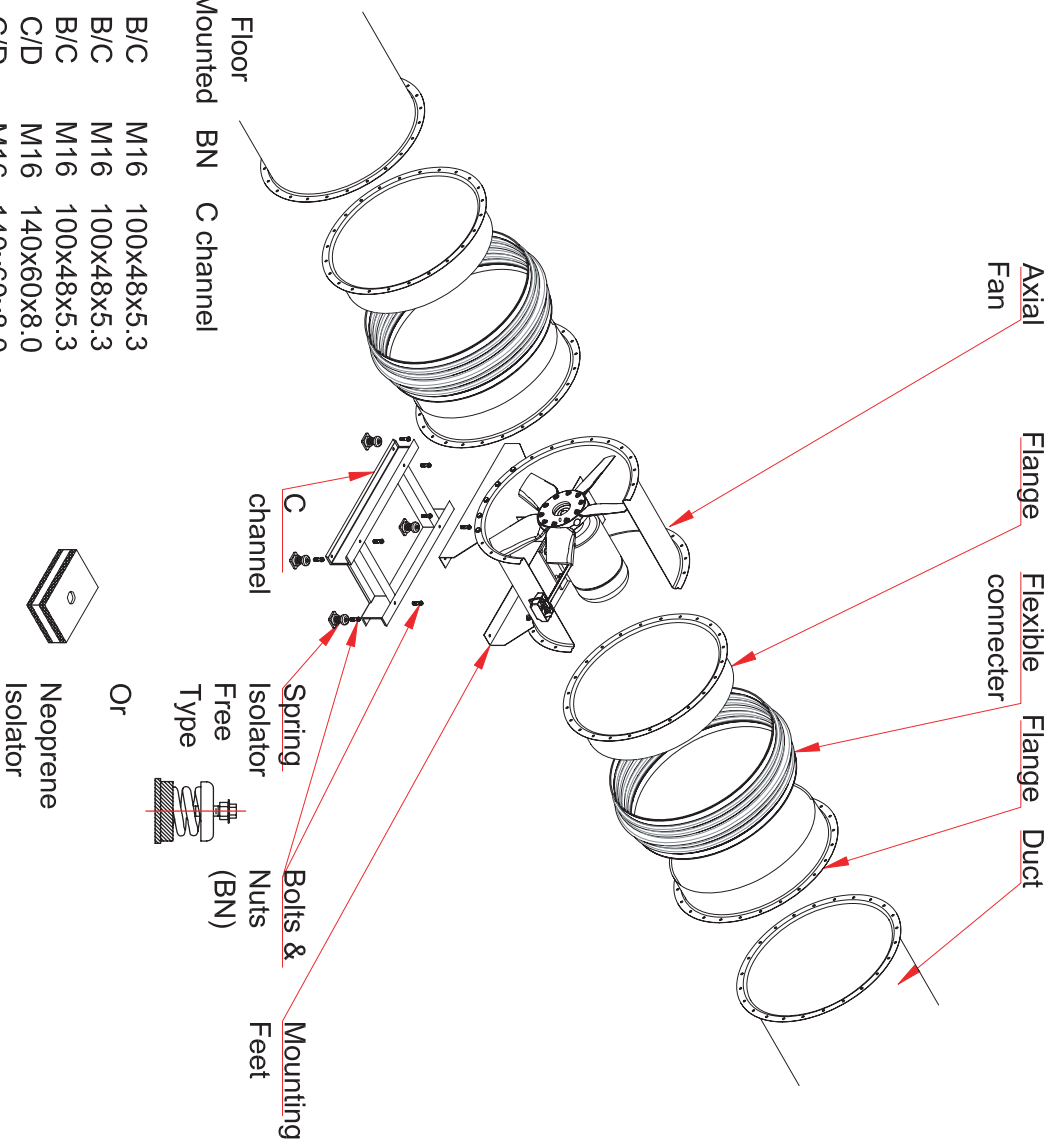

Model Size	OD	Length	Approx Weight(kg)	Total Floor Mounted	BN	C channel
AXV 560	664	400	189~212	B/C	M16	100x48x5.3
AXV 630	734	400	199~224	B/C	M16	100x48x5.3
AXV 710	814	400	193~220	B/C	M16	100x48x5.3
AXV 800	904	400	220~256	C/D	M16	140x60x8.0
AXV 900	1004	530	281~315	C/D	M16	140x60x8.0
AXV 1000	1105	530	357~419	C/D	M16	140x60x8.0
AXV 1120	1245	816	501~564	C/D	M16	140x60x8.0
AXV 1250	1370	816	585~652	C/D	M16	140x60x8.0

Remarks:
 Dimensions are in mm and approximate only and subjected to changes without prior notice.
 Drawing for reference only. Not for QC / Manufacturing purposes.

Model Size	OD	Length	Approx Weight(kg)	Total	
				Floor Mounted	BN C channel
AXV 800	904	400	220~256	C/D	M18 140X60X8.0 Axial
AXV 900	1004	530	281~315	C/D	M18 140X60X8.0 Fan
AXV 1000	1105	530	357~419	C/D	M18 140X60X8.0
AXV 1120	1245	816	501~564	C/D	M18 140X60X8.0
AXV 1250	1370	816	585~652	C/D	M18 140X60X8.0
AXV 1400	1525	1000	664~742	D/E	M18 140X60X8.0
AXV 1600	1725	1000	776~906	D/E	M20 160X65X8.5
AXV 1800	2010	1000	1041~1212	D/E	M20 160X65X8.5
AXV 2000	2440	2139	1331~1545	D/E	M20 160X65X8.5
AXV 2200	2630	2300	1427~1717	D/E	M20 160X65X8.5
AXV 2400	2740	2355	1874~2203	D/E	M24 160X65X8.5
AXV 2600	2840	2417	2024~2409	D/E	M24 160X65X8.5
AXV 2800	3150	2676	2982~3424	D/E	M24 160X65X8.5

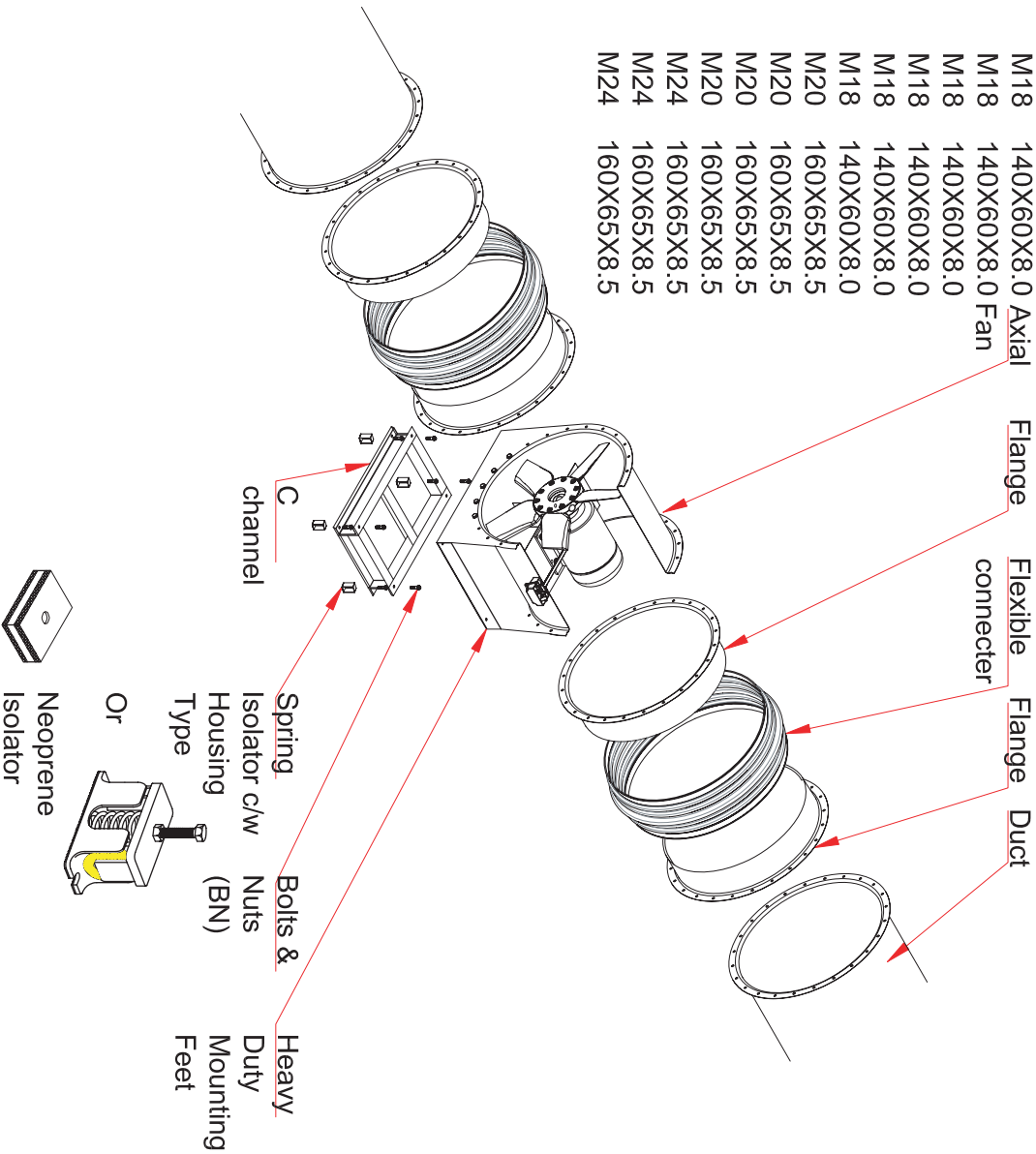

Floor Mounting Type D1 Installation

Remarks:

Dimensions are in mm and approximate only and subjected to changes without prior notice. Drawing for reference only. Not for QC / Manufacturing purposes.

Model Size	OD	Length	Approx Weight(kg)	Total	Floor	BN	C channel
				Mounted	Mounted		
AXV 800	904	400	220~256	C/D	M18	140X60X8.0	
AXV 900	1004	530	281~315	C/D	M18	140X60X8.0	
AXV 1000	1105	530	357~419	C/D	M18	140X60X8.0	
AXV 1120	1245	816	501~564	C/D	M18	140X60X8.0	
AXV 1250	1370	816	585~652	C/D	M18	140X60X8.0	
AXV 1400	1525	1000	664~742	D/E	M18	140X60X8.0	
AXV 1600	1725	1000	776~906	D/E	M20	160X65X8.5	
AXV 1800	2010	1000	1041~1212	D/E	M20	160X65X8.5	
AXV 2000	2440	2139	1331~1545	D/E	M20	160X65X8.5	
AXV 2200	2630	2300	1427~1717	D/E	M20	160X65X8.5	
AXV 2400	2740	2355	1874~2203	D/E	M24	160X65X8.5	
AXV 2600	2840	2417	2024~2409	D/E	M24	160X65X8.5	
AXV 2800	3150	2676	2982~3424	D/E	M24	160X65X8.5	

Floor Mounting Type D2 Installation

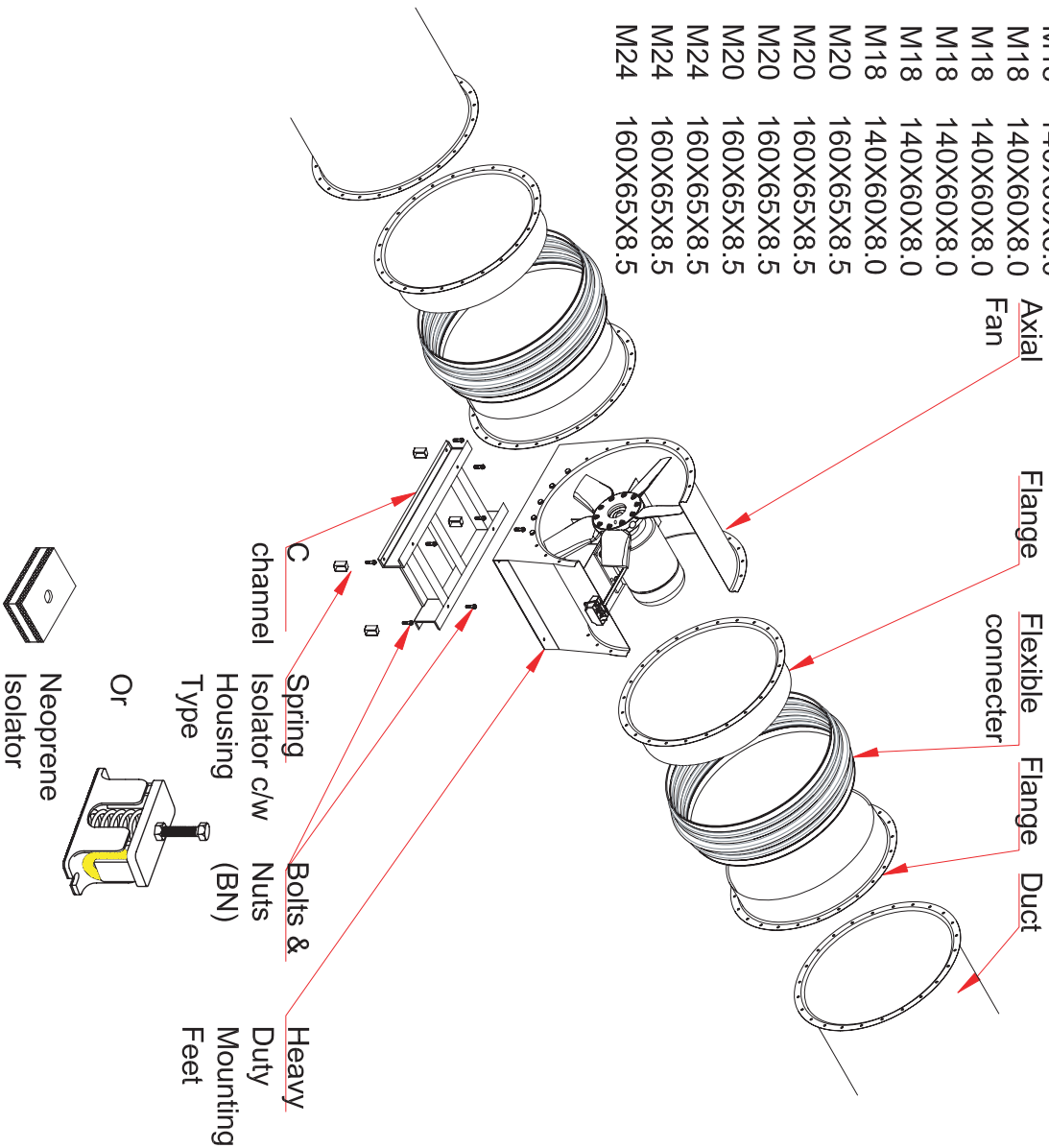

Remarks:
 Dimensions are in mm and approximate only and subjected to changes without prior notice.
 Drawing for reference only. Not for QC / Manufacturing purposes.

Model Size	OD	Length	Total		Floor	
			Approx Weight(kg)	Mounted	BN	C channel
AXV 1400	1525	1000	664~742	D/E	M18	140X60X8
AXV 1600	1725	1000	776~906	D/E	M20	160X65X8.5
AXV 1800	2010	1000	1041~1212	D/E	M20	160X65X8.5
AXV 2000	2440	2139	1331~1545	D/E	M20	160X65X8.5
AXV 2200	2630	2300	1427~1717	D/E	M20	160X65X8.5
AXV 2400	2740	2355	1874~2203	D/E	M24	180X70X9.0
AXV 2600	2840	2417	2024~2409	D/E	M24	180X70X9.0
AXV 2800	3150	2676	2982~3424	D/E	M24	180X70X9.0

Floor Mounting Type E1 Installation

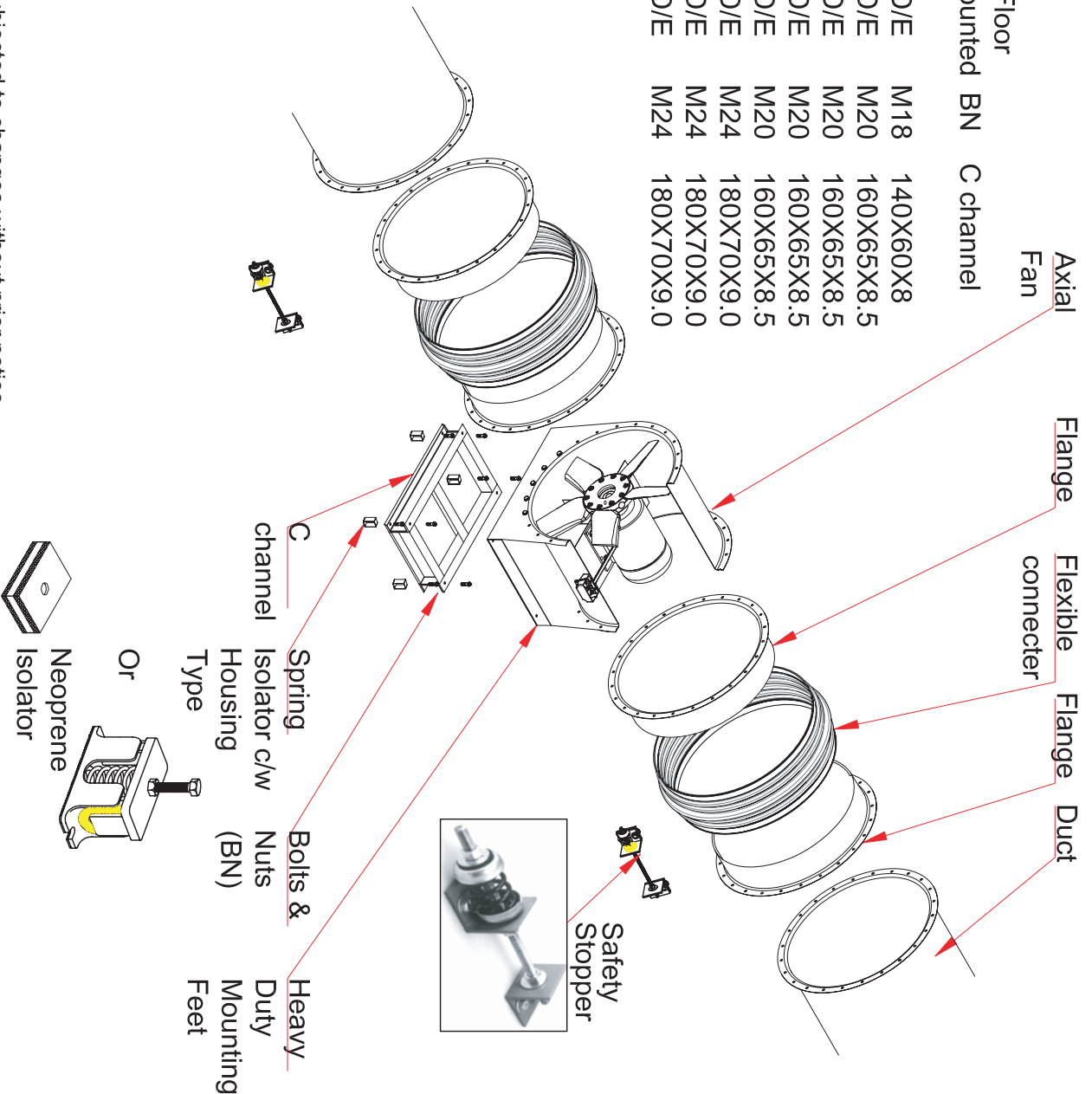

Remarks:
 Dimensions are in mm and approximate only and subjected to changes without prior notice.
 Drawing for reference only. Not for QC / Manufacturing purposes.

Model Size	OD	Length	Weight(kg)	Total		Floor Mounted		Axial Fan
				Approx	BN	C channel		
AXV 1400	1525	1000	664~742	D/E	M18	140X60X8		
AXV 1600	1725	1000	776~906	D/E	M20	160X65X8.5		
AXV 1800	2010	1000	1041~1212	D/E	M20	160X65X8.5		
AXV 2000	2440	2139	1331~1545	D/E	M20	160X65X8.5		
AXV 2200	2630	2300	1427~1717	D/E	M20	160X65X8.5		
AXV 2400	2740	2355	1874~2203	D/E	M24	180X70X9.0		
AXV 2600	2840	2417	2024~2409	D/E	M24	180X70X9.0		
AXV 2800	3150	2676	2982~3424	D/E	M24	180X70X9.0		

Floor Mounting Type E2 Installation

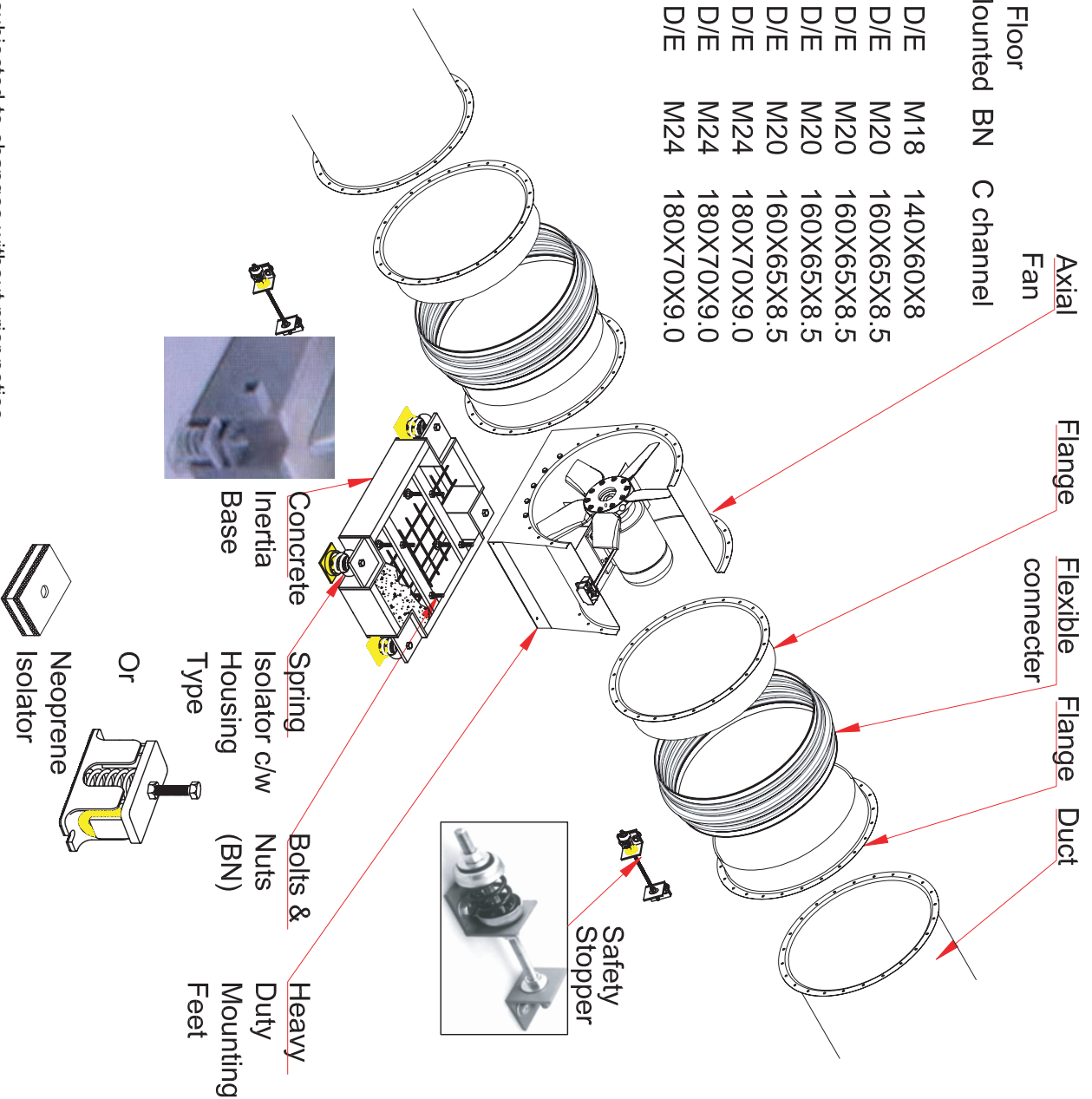

Remarks:
 Dimensions are in mm and approximate only and subjected to changes without prior notice.
 Drawing for reference only. Not for QC / Manufacturing purposes.

Model Size	OD	Length	Total Approx Weight	Ceiling Mounted Base	BN	Angle bar
AXV 315	398	350	31~37	A/B	M12	50X50X4
AXV 355	438	350	33~39	A/B	M12	50X50X4
AXV 400	484	400	46~52	A/B	M12	50X50X4
AXV 450	534	400	62~67	A/B	M12	50X50X4
AXV 500	584	400	67~73	A/B	M12	50X50X4
AXV 560	664	400	189~212	A/B	M16	50X50X4
AXV 630	734	400	199~224	A/B	M16	50X50X4

Ceiling Mounting Type A Base Installation

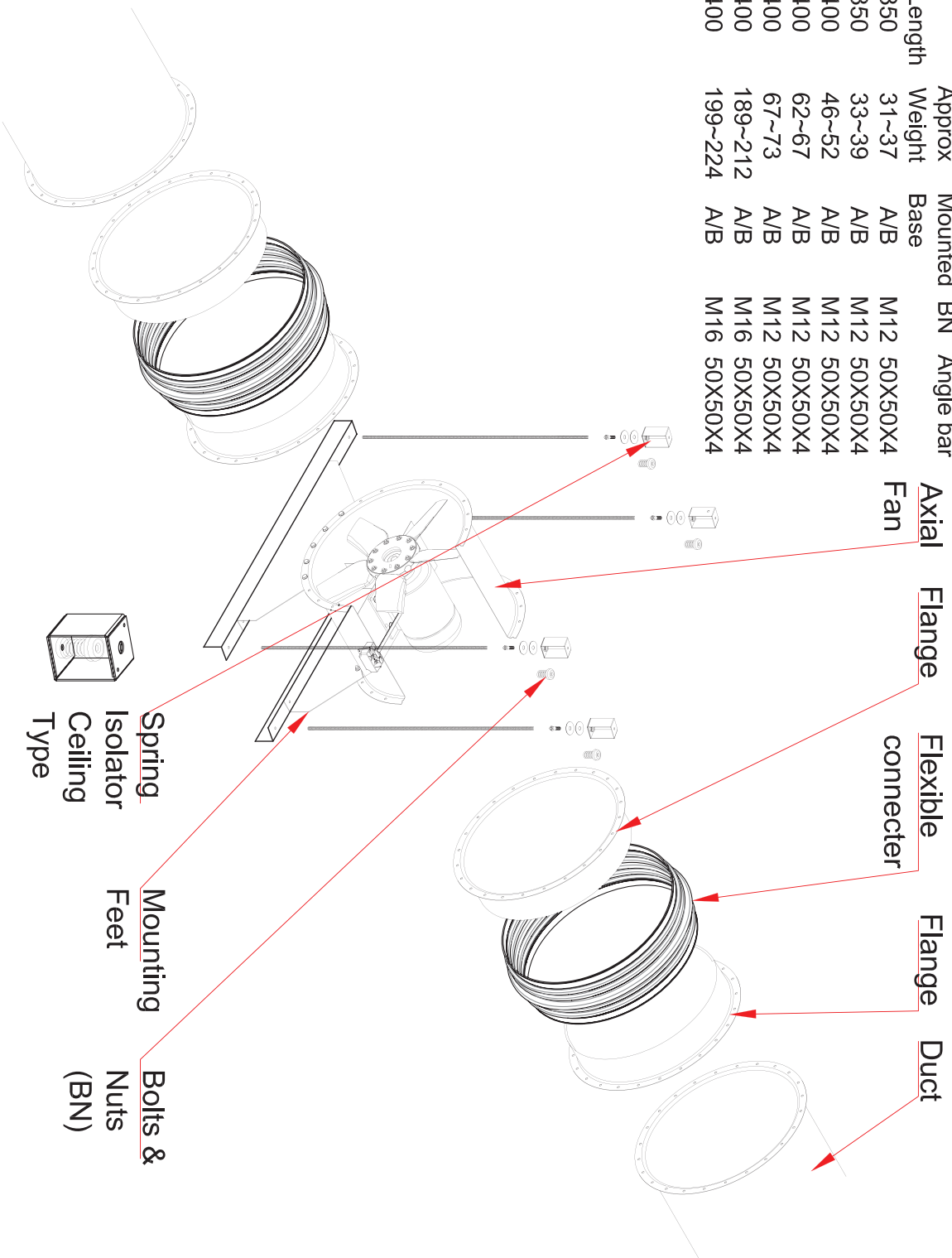

Remarks:
 Dimensions are in mm and approximate only and subjected to changes without prior notice.
 Drawing for reference only. Not for QC / Manufacturing purposes.

Model Size	OD	Length	Total		
			Approx Weight	Ceiling Mounted Base	BN Angle bar
AXV 315	398	350	31~37	A/B	M12 50X50X4
AXV 355	438	350	33~39	A/B	M12 50X50X4
AXV 400	484	400	46~52	A/B	M12 50X50X4
AXV 450	534	400	62~67	A/B	M12 50X50X4
AXV 500	584	400	67~73	A/B	M12 50X50X4
AXV 560	664	400	189~212	A/B	M16 63X63X8
AXV 630	734	400	199~224	A/B	M16 63X63X8
AXV 710	814	400	193~220	B/C	M16 63X63X8
AXV 800	904	400	220~256	B/C	M18 75X75X8
AXV 900	1004	530	281~315	B/C	M18 75X75X8
AXV 1000	1105	530	357~419	B/C	M18 75X75X8

Ceiling Mounting Type B Base Installation

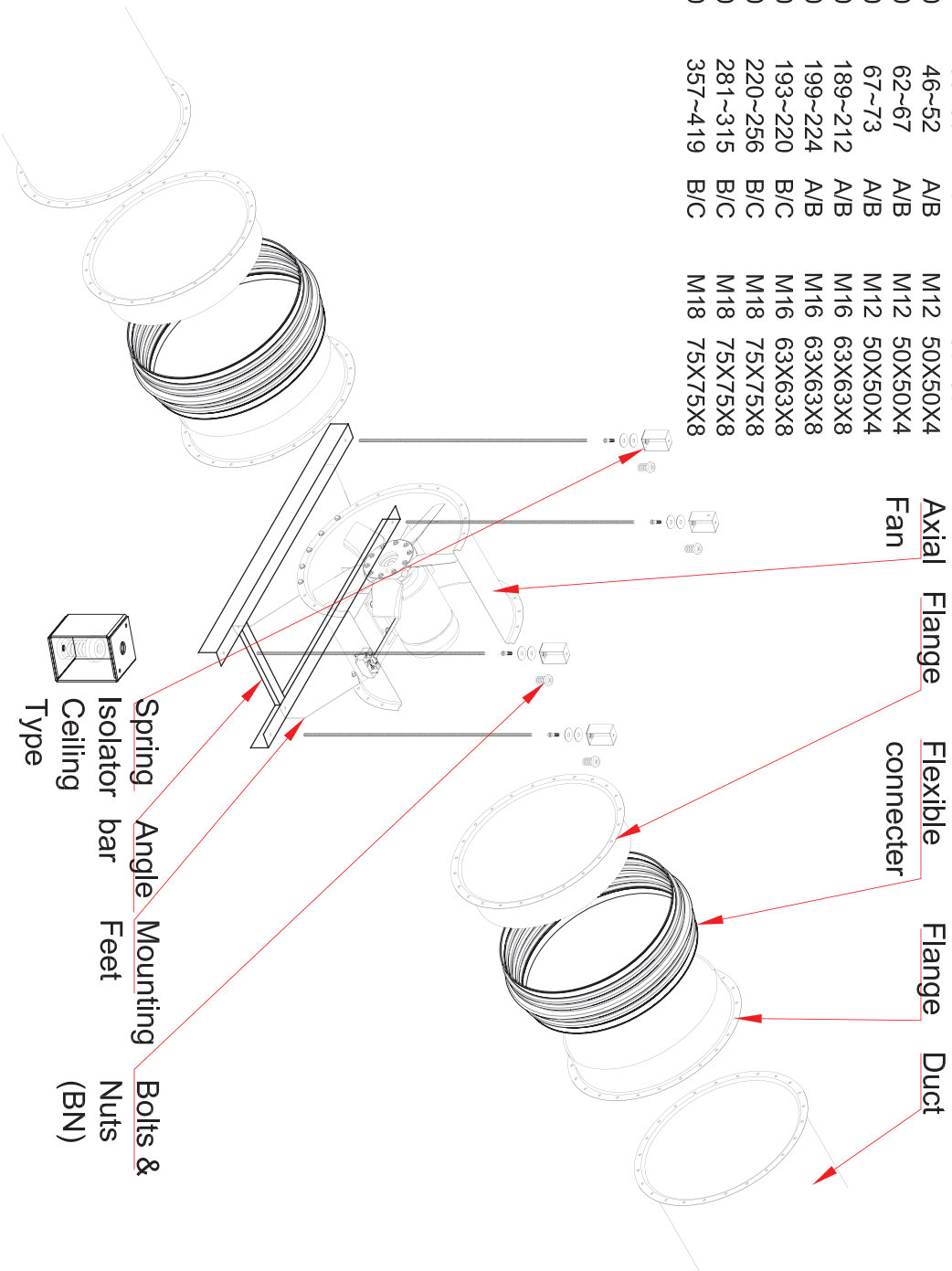

Remarks:
 Dimensions are in mm and approximate only and subjected to changes without prior notice.
 Drawing for reference only. Not for QC / Manufacturing purposes.

Model Size	OD	Length	Total Approx Weight	Ceiling Mounted Base	BN	C channel
AXV 710	814	400	193~220	B/C	M16	140X60X8.0
AXV 800	904	400	220~256	B/C	M18	160X65X8.5
AXV 900	1004	530	281~315	B/C	M18	160X65X8.5
AXV 1000	1105	530	357~419	B/C	M18	160X65X8.5
AXV 1120	1245	816	501~564	C/D	M18	160X65X8.5
AXV 1250	1370	816	585~652	C/D	M18	160X65X8.5

Ceiling Mounting Type C Base Installation

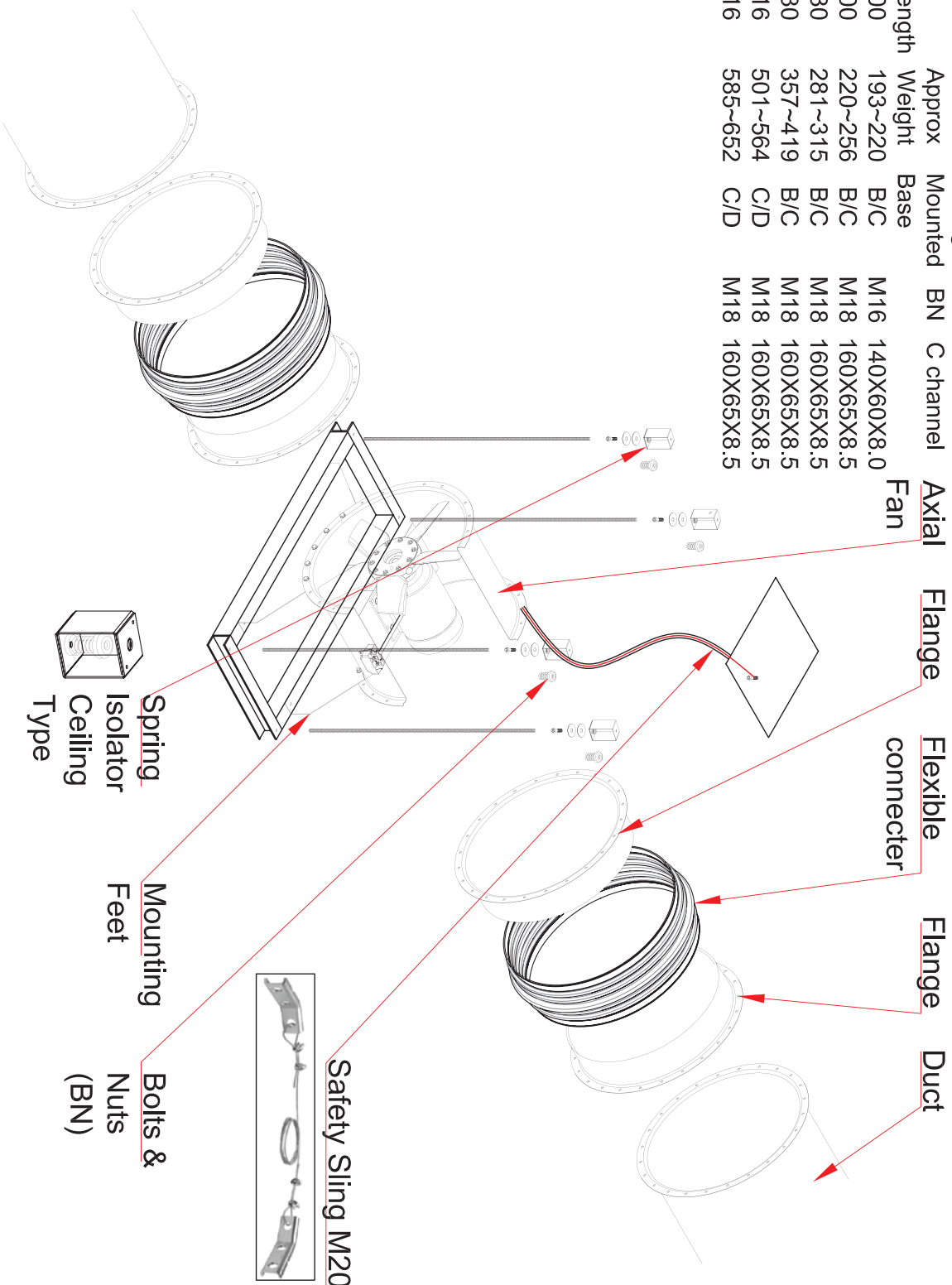

Remarks:
 Dimensions are in mm and approximate only and subjected to changes without prior notice.
 Drawing for reference only. Not for QC / Manufacturing purposes.
 For fans with motor power exceeding 75 kW, hanging arrangements are not advisable.

Model Size	OD	Length	Total Approx Weight	Ceiling Mounted Base	BN	C channel
AXV 1120	1245	816	501~564	C/D	M18	160X65X8.5
AXV 1250	1370	816	585~652	C/D	M18	160X65X8.5
AXV 1400	1525	1000	664~742	D	M18	160X65X8.5
AXV 1600	1725	1000	776~906	D	M18	160X65X8.5
AXV 1800	2010	1000	1041~1212	NR		
AXV 2000	2440	2139	1331~1545	NR		
AXV 2200	2630	2300	1427~1717	NR		
AXV 2400	2740	2355	1874~2203	NR		
AXV 2600	2840	2417	2024~2409	NR		
AXV 2800	3150	2676	2982~3424	NR		

NR : Not Recommended

Ceiling Mounting Type D Base Installation

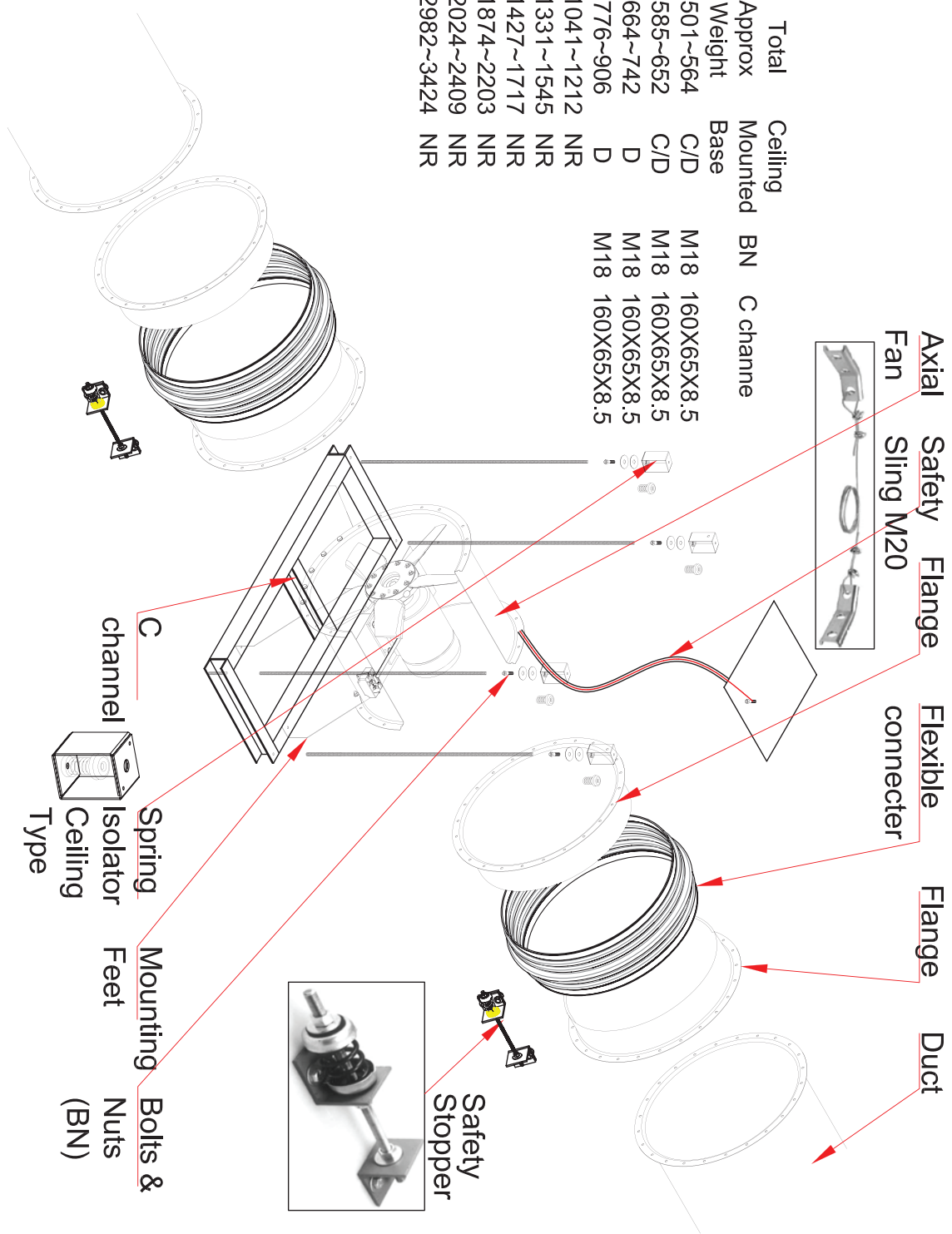

Remarks:
 Dimensions are in mm and approximate only and subjected to changes without prior notice.
 Drawing for reference only. Not for QC / Manufacturing purposes.
 For fans with motor power exceeding 75 kW, hanging arrangements are not advisable.

Model Size	OD	Length	Total Approx Weight	Ceiling Mounted Hanger	BN
AXV 315	398	350	31~37	A/B	M12
AXV 355	438	350	33~39	A/B	M12
AXV 400	484	400	46~52	A/B	M12
AXV 450	534	400	62~67	A/B	M12
AXV 500	584	400	67~73	A/B	M12
AXV 560	664	400	189~212	A/B	M16
AXV 630	734	400	199~224	A/B	M16

Ceiling Mounting Type A Hanger Installation

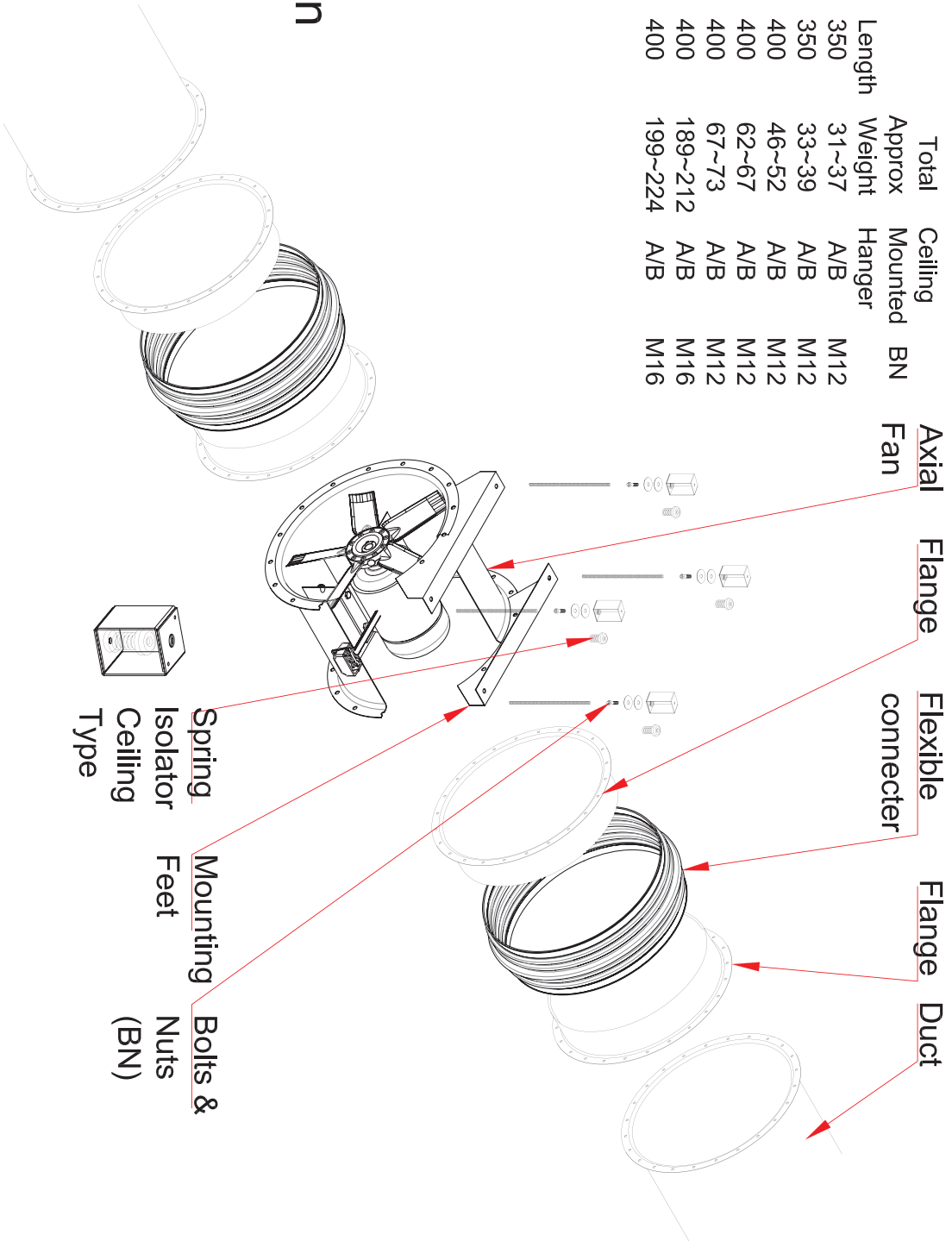

Remarks:
 Dimensions are in mm and approximate only and subjected to changes without prior notice.
 Drawing for reference only. Not for QC / Manufacturing purposes.

Model Size	OD	Length	Total Approx Weight	Ceiling Mounted Hanger	BN	C channel
AXV 710	814	400	193~220	B/C	M16	140X60X8
AXV 800	904	400	220~256	B/C	M18	140X60X8
AXV 900	1004	530	281~315	B/C	M18	140X60X8
AXV 1000	1105	530	357~419	B/C	M18	140X60X8

Ceiling Mounting Type B Hanger Installation

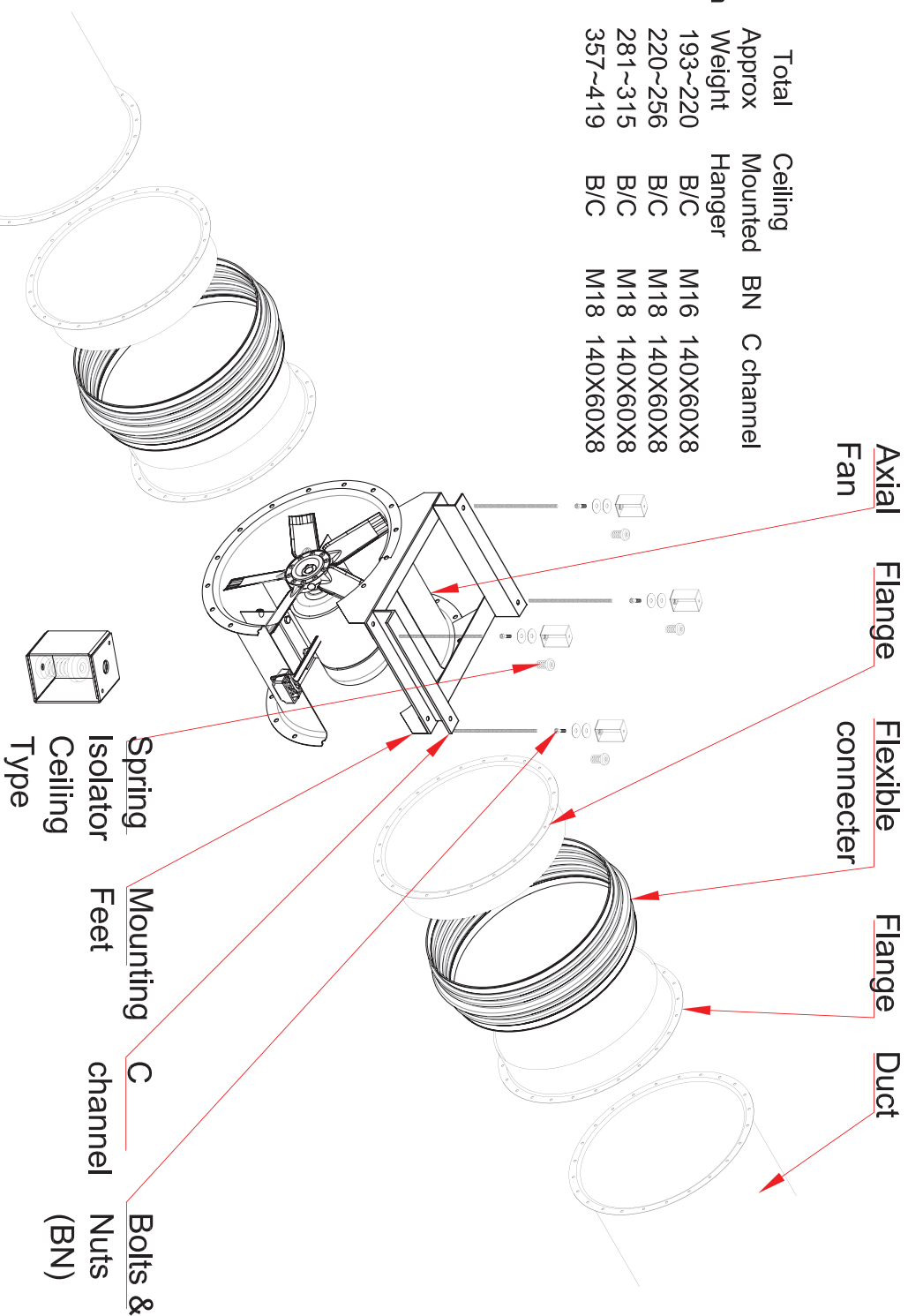

Remarks:
 Dimensions are in mm and approximate only and subjected to changes without prior notice.
 Drawing for reference only. Not for QC / Manufacturing purposes.

Model Size	OD	Length	Total Approx Weight	Ceiling Mounted Hanger	BN	C channel
AXV 710	814	400	193~220	B/C	M16	140X60X8.0
AXV 800	904	400	220~256	B/C	M18	160X65X8.5
AXV 900	1004	530	281~315	B/C	M18	160X65X8.5
AXV 1000	1105	530	357~419	B/C	M18	160X65X8.5
AXV 1120	1245	816	501~564	C/D	M18	160X65X8.5
AXV 1250	1370	816	585~652	C/D	M18	160X65X8.5

Ceiling Mounting Type C Hanger Installation

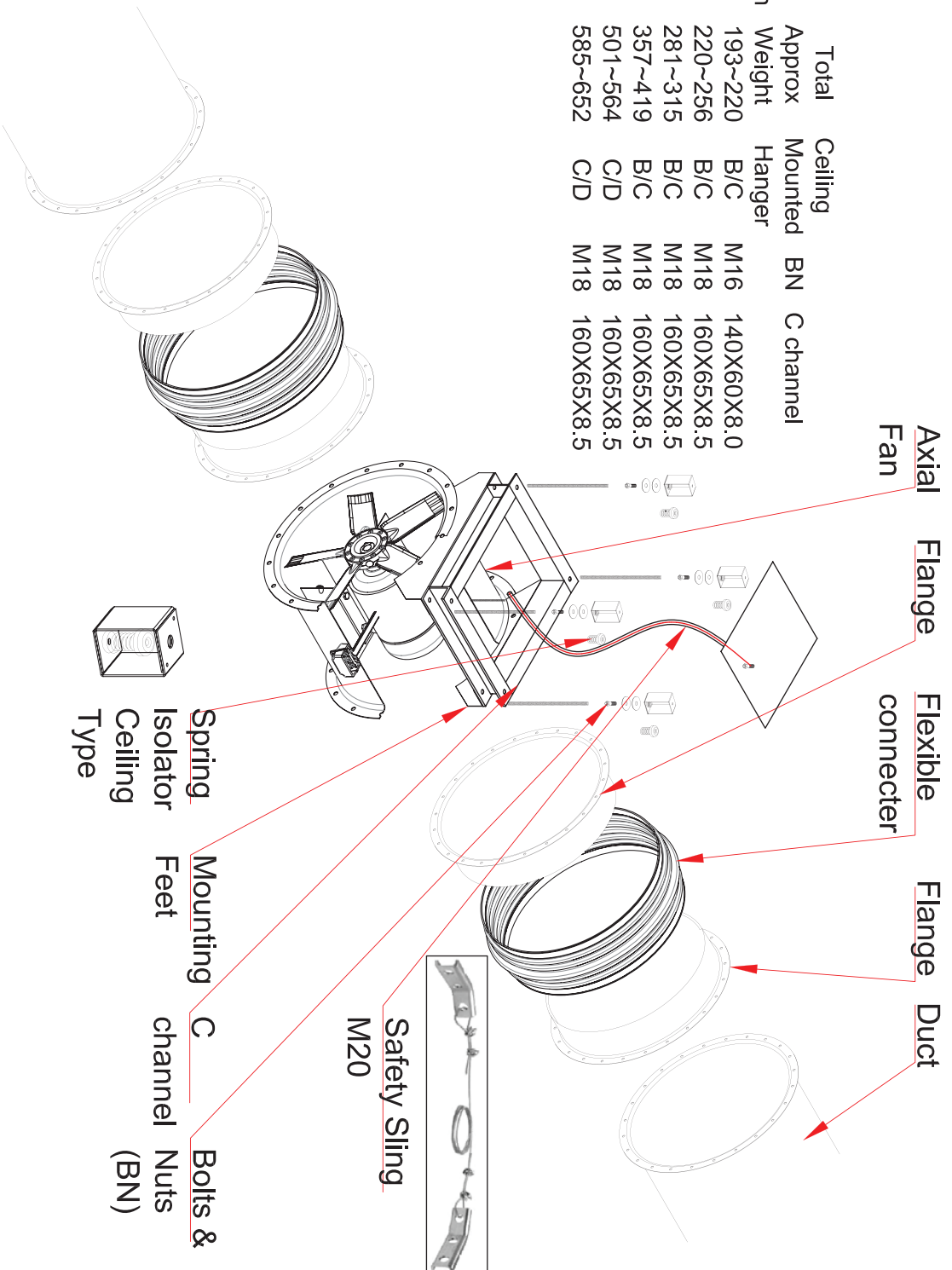

Remarks:

Dimensions are in mm and approximate only and subjected to changes without prior notice. Drawing for reference only. Not for QC / Manufacturing purposes.

For fans with motor power exceeding 75 kW, hanging arrangements are not advisable.

Model Size	OD	Length	Total Approx Weight	Ceiling Mounted Hanger	BN	C channel
AXV 1120	1245	816	501~564	C/D	M18	160X65X8.5
AXV 1250	1370	816	585~652	C/D	M18	160X65X8.5
AXV 1400	1525	1000	664~742	D	M18	160X65X8.5
AXV 1600	1725	1000	776~906	D	M18	160X65X8.5
AXV 1800	2010	1000	1041~1212	NR		
AXV 2000	2440	2139	1331~1545	NR		
AXV 2200	2630	2300	1427~1717	NR		
AXV 2400	2740	2355	1874~2203	NR		
AXV 2600	2840	2417	2024~2409	NR		
AXV 2800	3150	2676	2982~3424	NR		

NR : Not Recommended

Ceiling Mounting Type D Hanger Installation

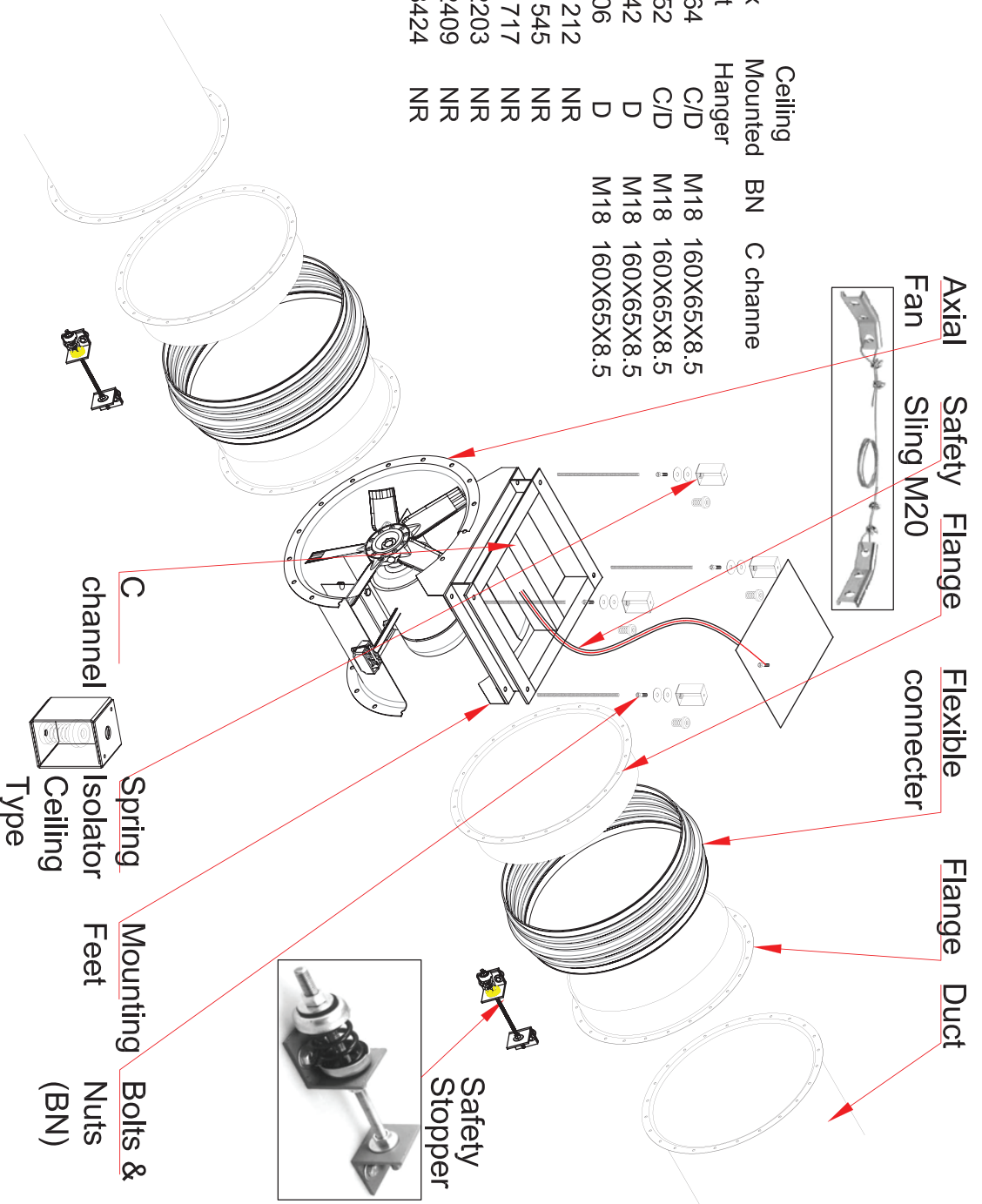

Remarks:
 Dimensions are in mm and approximate only and subjected to changes without prior notice.
 Drawing for reference only. Not for QC / Manufacturing purposes.
 For fans with motor power exceeding 75 kW, hanging arrangements are not advisable.

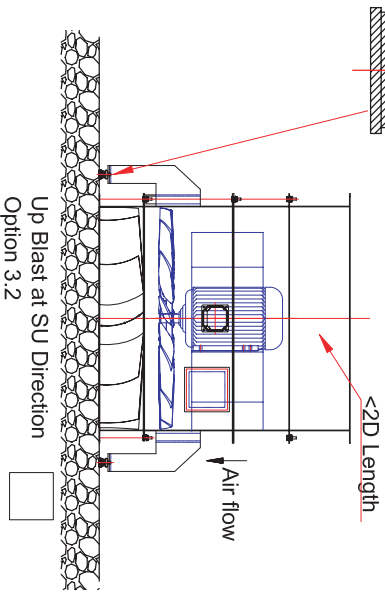
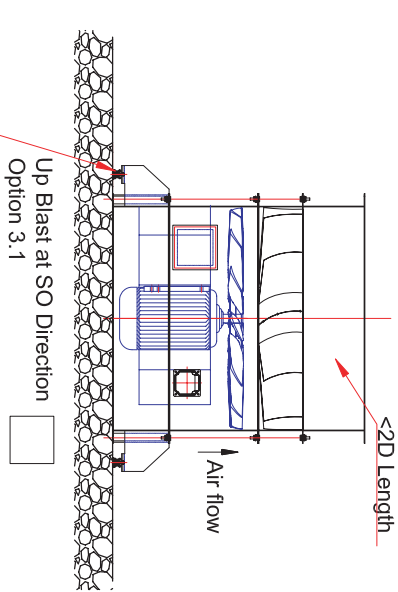

3 Footer with Circular Platform Opening

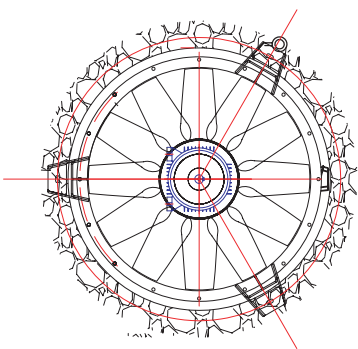

Vertical Mounting
Type A1 Installation

Model Size	OD	Length	Approx Weight	Total Vertical Mounted
AXV 315	398	350	31~37	<2D A1/2
AXV 355	438	350	33~39	A1/2
AXV 400	484	400	46~52	A1/2
AXV 450	534	400	62~67	A1/2
AXV 500	584	400	67~73	A1/2
AXV 560	664	400	189~212	A1/2
AXV 630	734	400	199~224	A1/2
AXV 710	814	400	193~220	A1/2
AXV 800	904	400	220~256	A1/2
AXV 900	1004	530	281~315	A1/2
AXV 1000	1105	530	357~419	A1/2
AXV 1120	1245	816	501~564	A1/2/C1/2
AXV 1250	1370	816	585~652	A1/2/C1/2

4 Footer with Square Platform Opening

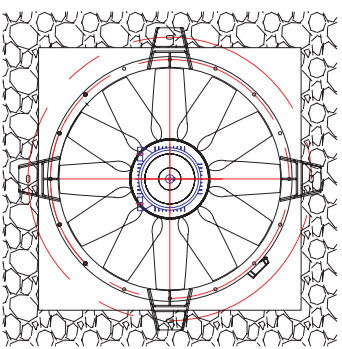

Vertical Mounting
Type A2 Installation

Remarks:
Dimensions are in mm and approximate only and subjected to changes without prior notice.
Drawing for reference only. Not for QC / Manufacturing purposes.

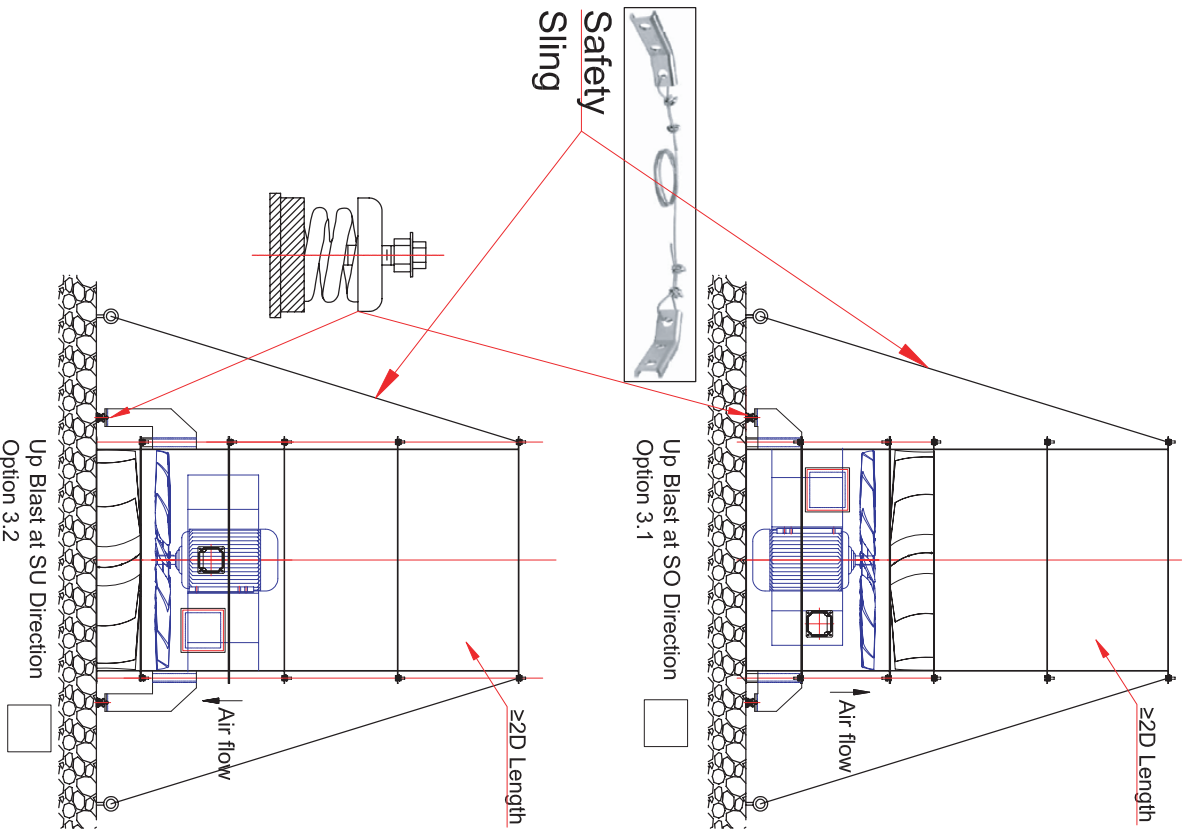

3 Footer with Circular Platform Opening

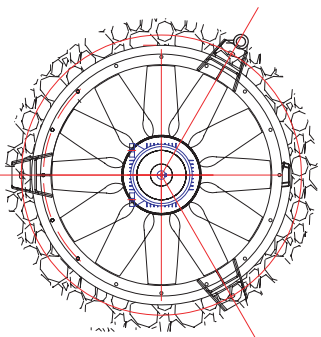

Model Size	OD	Length	Approx Weight	Total Vertical Mounted
AXV 315	398	350	31~37	>2D
AXV 355	438	350	33~39	B1/2
AXV 400	484	400	46~52	B1/2
AXV 450	534	400	62~67	B1/2
AXV 500	584	400	67~73	B1/2
AXV 560	664	400	189~212	B1/2
AXV 630	734	400	199~224	B1/2
AXV 710	814	400	193~220	B1/2
AXV 800	904	400	220~256	B1/2
AXV 900	1004	530	281~315	B1/2
AXV 1000	1105	530	357~419	B1/2
AXV 1120	1245	816	501~564	B1/2/D1/2
AXV 1250	1370	816	585~652	B1/2/D1/2

Vertical Mounting Type B1 Installation

4 Footer with Square Platform Opening

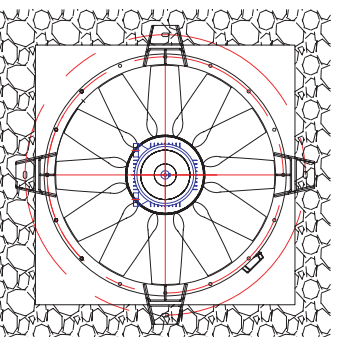

Vertical Mounting Type B2 Installation

Remarks:
 Dimensions are in mm and approximate only and subjected to changes without prior notice.
 Drawing for reference only. Not for QC / Manufacturing purposes.

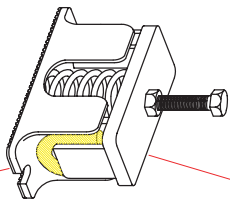
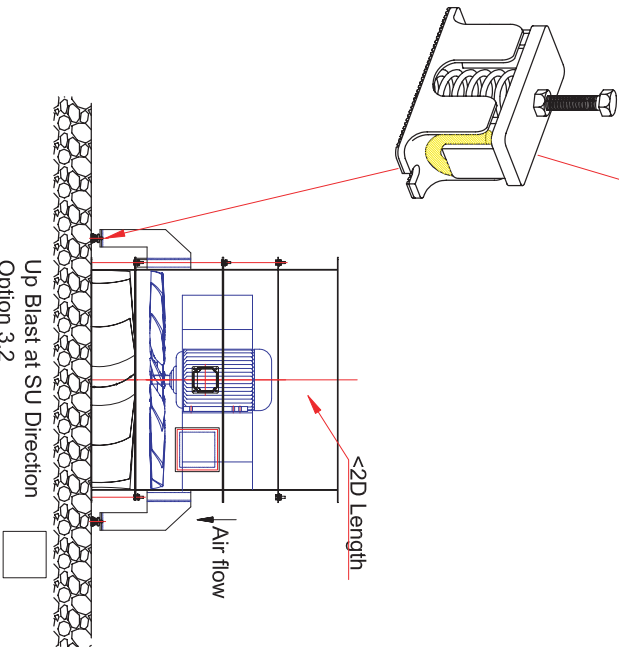
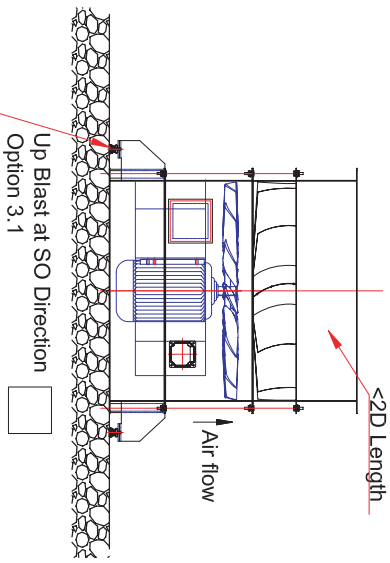

3 Footer with Circular Platform Opening

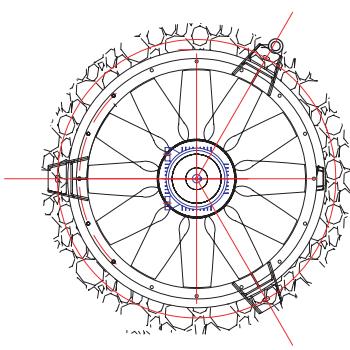

Vertical Mounting
Type C1 Installation

Model Size	OD	Length	Weight	Total	Vertical
				Approx	Mounted
AXV 1120	1245	816	501~564	A1/2/C1/2	<2D
AXV 1250	1370	816	585~652	A1/2/C1/2	
AXV 1400	1525	1000	664~742	C1/2	
AXV 1600	1725	1000	776~906	C1/2	
AXV 1800	2010	1000	1041~1212	C1/2	
AXV 2000	2440	2139	1331~1545	C1/2	
AXV 2200	2630	2300	1427~1717	C1/2	
AXV 2400	2740	2355	1874~2203	C1/2	
AXV 2600	2840	2417	2024~2409	C1/2	
AXV 2800	3150	2676	2982~3424	C1/2	

4 Footer with Square Platform Opening

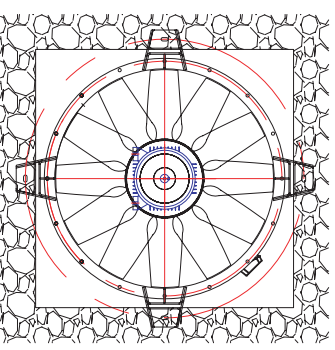

Vertical Mounting
Type C2 Installation

Remarks:
Dimensions are in mm and approximate only and subjected to changes without prior notice.
Drawing for reference only. Not for QC / Manufacturing purposes.

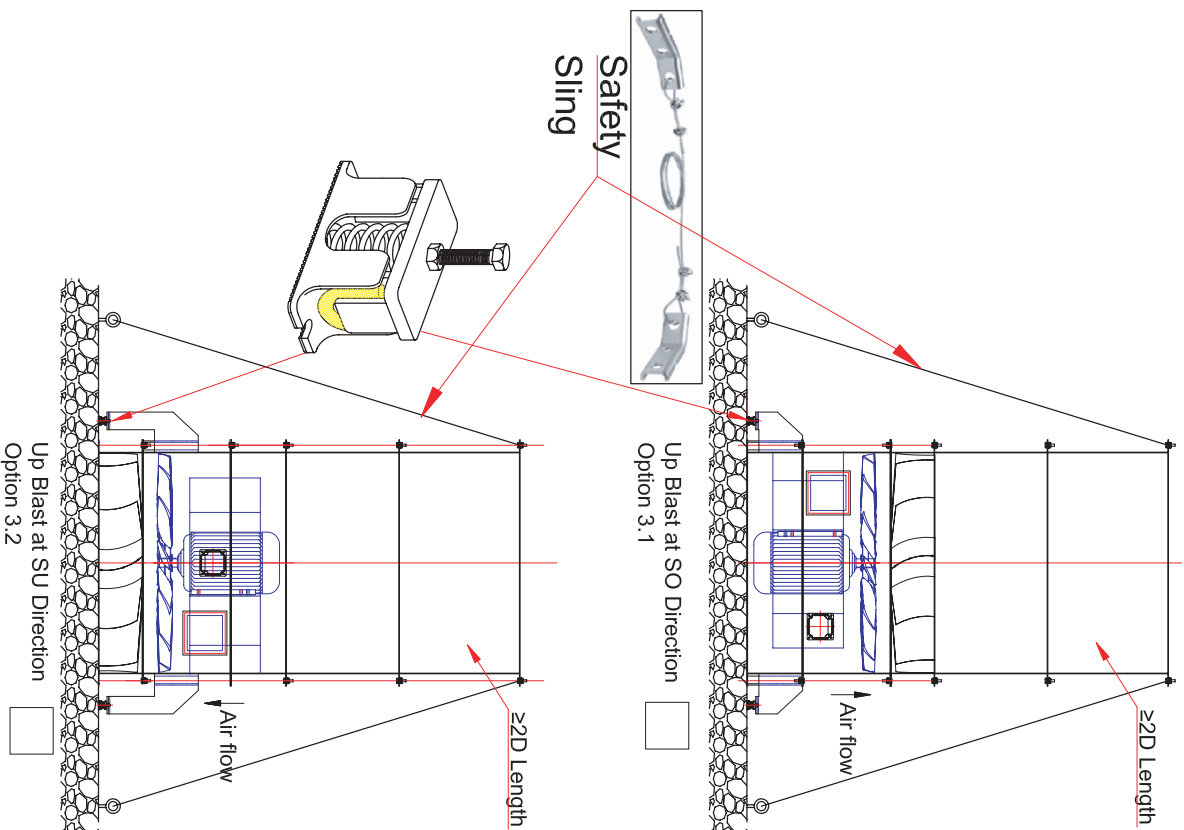

3 Footer with Circular Platform Opening

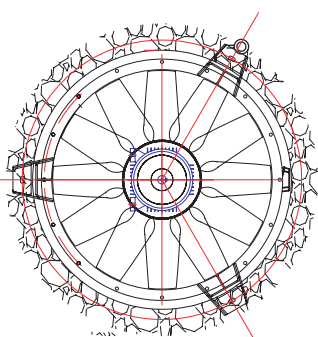

Model Size	OD	Length	Approx Weight	Vertical Mounted	
				>2D	D1/2
AXV 1120	1245	816	501~564	B1/2/D1/2	D1/2
AXV 1250	1370	816	585~652	B1/2/D1/2	D1/2
AXV 1400	1525	1000	664~742	D1/2	D1/2
AXV 1600	1725	1000	776~906	D1/2	D1/2
AXV 1800	2010	1000	1041~1212	D1/2	D1/2
AXV 2000	2440	2139	1331~1545	D1/2	D1/2
AXV 2200	2630	2300	1427~1717	D1/2	D1/2
AXV 2400	2740	2355	1874~2203	D1/2	D1/2
AXV 2600	2840	2417	2024~2409	D1/2	D1/2
AXV 2800	3150	2676	2982~3424	D1/2	D1/2

Vertical Mounting Type D1 Installation

4 Footer with Square Platform Opening

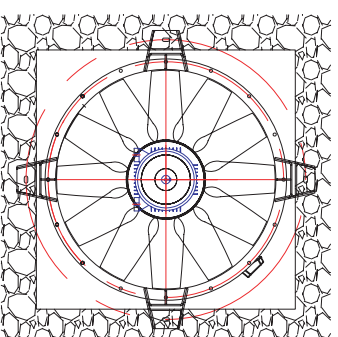

Vertical Mounting Type D2 Installation

Remarks:
 Dimensions are in mm and approximate only and subjected to changes without prior notice.
 Drawing for reference only. Not for QC / Manufacturing purposes.

8.3 Functional description and mounting instruction for impellers and pulleys having taper lock bushes

Accessibility:

At first the impeller must be made accessible.

For axial fans the fan in general must be dismounted and placed on a level surface with the impeller pointing upwards. Exceptions are swing out type axial fans and fans inside jet cowls where the impeller is accessible after opening the door.

Functional description:

The hub has a conical inner bore. A conical bush that is cylindrical inside is inserted. While tightening the fixing screws, the bush is tightened and clamped between the shaft and hub

Dismounting of impeller

- a) If corroded use rust dissolving oil. Do not use hammers, crowbars or other use of force.
- b) Detach all screws. Depending on size of the bush, unscrew one or two screws, oil them and screw them into the set bores.
- c) Tighten screw(s) uniformly, until the bush comes out of the hub, so that the bush can move freely on the shaft.
- d) Remove impeller with the bush from the shaft.

- Pull-off bore
- Fixing bore

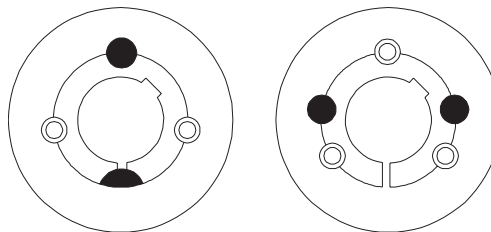

Bush	Torque [NM]	Screws		Hub size [MM]	Bush	Torque [NM]	Screws		Hub size [MM]	Bush	Torque [NM]	Screws		Hub size [MM]
		No.	Size				No.	Size				No.	Size	
1008	5.6	2	1/4"x1/2"	-	2012	31	2	7/16"x7/8"	250	4040	170	3	5/8"x1 ³ / ₄ "	-
1108			BSW	-				BSW					-	BSW
1310	20	2	3/8"x5/8"	-	2517	48	2	1/2"x1"	300	4545	192	3	3/4"x2"	1000
1315			BSW	-				BSW					-	
1210	20	2	3/8"x5/8"	150	3020	90	2	5/8"x1 ¹ / ₄ "	370, 420, 550	5050	271	3	7/8"x2 ¹ / ₄ "	-
1215				-					-					BSW
1610	20	2	3/8"x5/8"	200	3535	112	3	1/2"x1 ¹ / ₂ "	750					
1615				-						-	BSW	-	BSW	-

Remounting of the impeller

- a) Clean and degrease all uncovered surfaces, such as the bore and the conical surface of the taperlock bush as well as the conical bore of the hub. Insert the taperlock bush into the hub and superimpose all connection bores (half-thread bores must always have half-plain bores on the opposite side).
- b) Slightly oil and screw in threaded stud (Gr. 1008 - 3030) and/or cylindrical screws (Gr. 3535 - 5050). Don't fix screws tightly.
- c) Clean and grease shaft. Push disc with taperlock bush onto the shaft until desired place is found.
- d) When using a slot key, place it first into the slot. Between slot key and bore slot there must be a small gap.
- e) Tighten thread studs and/or cylinder screws uniformly by using a screw driver, DIN 911, with the torques indicated in the table.
- f) After a short time of operation (1/2 or 1 hour) check torque of the screws and correct if necessary.

8.4 Belt Drive (BD)

Electric motors and other driving equipment must be properly aligned and mounted on the flat base free from distortion. Slide rails must be positioned so that sufficient allowance is made for adjustment of drive center and changing of belts. Before fitting a pulley, the bore, the shaft and taper bush must be thoroughly cleaned. Alignment of belts and pulleys is important and must be checked in all planes.

- 1) Align the sheaves carefully to avoid axial thrust on the bearing.
- 2) Adjust the belt tension to just prevent slippage when the motor is running at full load. Excessive belt tensions will cause unnecessary loading on the bearing.
- 3) On high inertia load applications, belts may be tightened to prevent squealing and slipping during acceleration. Generally, belts should be allowed to slip during acceleration to avoid the possibility of overloading the motor bearing.
- 4) It is essential that all the belts be practically of the same length, as one or two belts longer than the rest will mean that the remainders must carry the entire load. A slight variation is permissible as this will work itself out after a few days and the motor can be tightened by moving it along the slide rails.
- 5) They should be re-tighten after the fan has been running for a few days (36hrs) and periodically checked for tension.
- 6) Regular control of belt tension is very important. In any case, the belt tension has to be controlled after the first 100 operating hours, and then every 1000 operating hours or at least once a year. The belt tension is controlled by “pressing the belt with the fingers” (See drawing 1). A good tension is achieved by a total bending of approx. 2-3cm. Used belts have to be replaced by belts of the same type. Control at the same time the fixation of the belt disc at the axis and the alignment of the belt. (See drawing 2 as below)

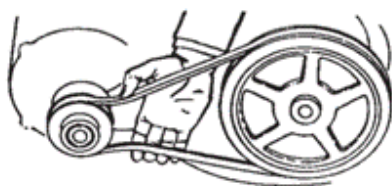
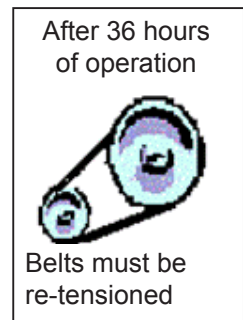

1) Max bending allowed is approx. 2-3 cm

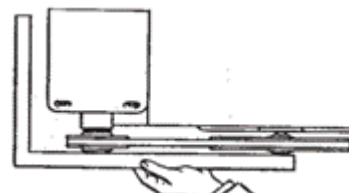

2) Alignment of the belt disc

Belts will be stretched in the course of time, especially during the initial operating phase. Therefore regular checks and re-tightening of the belts are necessary. The values given in the table below as well as those in the separate documentation must be observed. Very high tension increases the bearing load (risk of damage to the bearings), while a very low tension leads to belt slip, and a very low tension leads to belt slip, creaking and additional wear. Re-tightening is possible by parallel shifting of the motor in its rails or lifting the motor pivot. Care has to be taken to see that the pulleys remain strictly parallel to each other (use a ruler or a piece of string). The correct belt tension can be determined by measuring the deflection E_a using a spring balance. If belts are to be replaced it should always be done intermittently (equal length). Replacing a single belt is strictly not permitted. New belts must be fitted with extreme care to avoid overstretching. For new belts the initial tension should be set higher, so that the deflection measures $0.75 \times$ the tabular value. For re-tightening, the tabular value or the value from the special documentation should be used.

3) Belt tension for standard V-belt types

Impression depth per belt E_a in mm
 Test force per belt f in N
 Centric distance L in mm

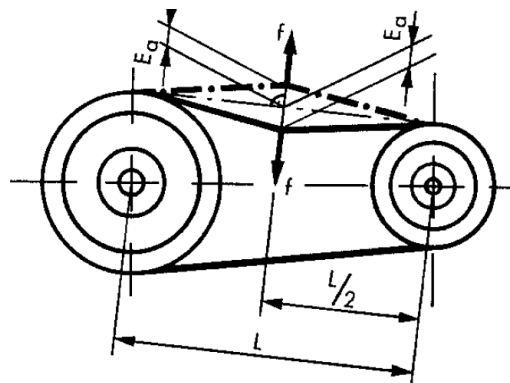

We recommend the following intervals for re-stretching:

1. Check: 2 to 3 hours after start-up,
 2. Check: 8 to 12 hours after start-up,
 3. Check: 1 week after start-up,
- Further checks according to requirements and operating conditions.

8.4.1 Pretension for V-belts

The centric distance L between the pulleys is measured and a defined force f (see table) is applied at the middle of the belts. Then the deflection E_a is measured and the tension is adjusted until the E_a value from the table is reached.

Example:

A belt drive has 180 Ø as the smallest pulley diameter, a SPB profile and $L = 1000\text{mm}$.

For a force of 75 N/belt the deflection

$$\text{For re-tightening } E_a = \frac{3,32 \times 1000}{100} = 33,2 \text{ mm}$$

For the initial set up with new belts E_a should be $E_a = 0,75 \times 33,2 = 24,9 \text{ mm}$.

Table 1, Test force and deflection of belts

Profile	Test force f per V-belt	Diameter of the smallest pulley	Deflection depth E_a Per 10mm center distance
	$f(\text{N})$	$(d_k \text{ mm})$	$E_a (\text{mm})$ Standard
SPZ	25	$56 \leq 71$	3,19
		$> 71 \leq 90$	2,86
		$> 90 \leq 125$	2,67
		> 125	2,47
SPA	50	$71 \leq 100$	4,16
		$> 100 \leq 140$	3,58
		$> 140 \leq 200$	3,33
		> 200	3,19
SPB	75	$112 \leq 160$	3,90
		$> 160 \leq 224$	3,32
		$> 224 \leq 355$	2,89
		> 355	2,73

The V belt drives, which connect the driving mechanism to the fan, create potential DANGER to the personnel and suitable guards should be provided. Bearing assemblies should be covered so that no rotating element can snag clothing or skin. Any open sheaves, pulleys, belts and other similar transmission device should be enclosed by guards.

8.4.2 Cleaning and replacing bearings

When dismantle the housing, the bearings should be cleaned off old grease by washing with a grease dissolving solvent.

In the event of bearing replacements, the bearing fitted should be of the same size as that shown on the nameplate.

The bearing should be an easy and smooth fit in the housing and on the shaft. Care must be taken to ensure that the contacting surfaces are parallel, otherwise damages may result.

Mounting snl housings with double-lip seals

Before starting installation work, the following instructions should be carefully read.

- 1) Ensure that the environment is clean. Check the dimensional and form accuracy of the shaft seating.
- 2) Check that the surface roughness of the support surface $R \leq 12.5\mu\text{m}$. The flatness (planicity) tolerance should be to IT7. For moderate demands IT8 may be satisfactory.
- 3) If the bearing is mounted on an adapter sleeve, determine the position of the housing. The grease nipple arranged at one side of the housing cap (for improved lubrication) should always be at the side opposite to the sleeve nut. It is necessary to consider the complete housing as the base and cap will only fit together as supplied.
- 4) Position the housing on the support surface. Fit the attachment bolts but do not tighten them.
- 5) Insert one seal half in each of the grooves in the housing base. Fill the space between the two sealing lips with grease. If the housing is to be used at the end of a shaft, insert an end cover at one side instead of the seal half.
- 6) Mount the bearing on the shaft-either directly on a stepped shaft or using an adapter sleeve. Completely fill the bearing with grease. The remainder of the recommended grease quantity should be put in the housing base at the sides.
- 7) Lay the shaft with bearing in the housing base.
- 8) Put one locating ring (when needed) at each side of the bearing.
NB. Locating rings are only used for locating bearing arrangements, except for CARB bearings which, although always non-locating, must always be mounted with locating rings.
- 9) Carefully align the housing base. Vertical markings at the middle of the side faces and ends of the housing base can facilitate this. Then lightly tighten the attachment bolts.
- 10) The remaining seal halves should be inserted in the seal grooves in the housing cap and the space between the sealing lips filled with grease.
- 11) The housing cap should be placed over the base and the cap bolts (to join cap and base) tightened to the torque specified in picture. The cap and base of one housing are not interchangeable with those of other housings. The cap and base should be checked to see that they bear the same identification.
- 12) Fully tighten the attachment bolts in the housing base.

8.4.3 Fan Belt Guard

1) Purpose of the Fan Belt Guard

The fan belt guard is a protective cover that shields the drive belt and pulley system. Its primary functions are:

- Personnel Protection: Prevents accidental contact with moving belts and pulleys, which can cause severe entanglement and laceration injuries.
- Equipment Protection: Keeps tools, debris, and other objects from falling into the moving parts, which could damage the fan impeller or cause imbalance.
- Compliance: Its proper installation and securement are mandated by workplace safety regulations like OSHA Standard #1910.212.

2) General Safety Protocols for BD Axial fan Operation

Safety with the belt guard starts with broader axial fan safety. Key non-negotiable rules include:

- Lockout/Tagout (LOTO): Before any maintenance, including guard inspection, you must de-energize and lock out the fan's power source.
- Rotor Security: Always double-check that the rotor is correctly and securely locked to the drive spindle before starting.
- Proper Balancing: Loads must be symmetrically balanced within the manufacturer's tolerance. Always run with all buckets in place.
- Rotor Inspection: Visually inspect rotors before each use for corrosion, scratches, cracks, or fatigue. Never use a damaged rotor.

3) Visual Inspection Procedure for the Belt Guard

Perform this check during regular axial fan inspections and before any maintenance.

Frequency: Weekly or before each use (if fan is used infrequently).

Procedure:

- a. Ensure the fan is powered off.
- b. Secure Attachment: Check that all screws, bolts, or fasteners securing the guard are present and tight. A loose guard is a major hazard.
- c. Structural Integrity: Look for any cracks, dents, warping, or signs of physical damage that could compromise its strength.
- d. Clearance and Alignment: Verify the guard does not rub against the belt or pulley. It should be close enough to prevent access but not contact moving parts.
- e. Cleanliness: Check for excessive dust, grease, or sample residue on or inside the guard.

4) Maintenance & Cleaning Tasks

Frequency: Monthly or Quarterly (adjust based on usage and environment).

Task 1: Guard Removal for Deeper Inspection

- Procedure: Follow LOTO. Remove the guard's fasteners carefully. Note their position and quantity. Lift the guard straight off.
- Warning: Some guards may be large and flexible; handle with care to avoid injury or bending.

Task 2: Drive Belt Inspection (with guard removed)

- Check the belt for signs of wear: cracks, fraying, glazing (shiny patches), or material loss.
- Check belt tension according to the manufacturer's manual. It should not be too loose (slipping) or too tight (excessive bearing wear).

Task 3: Guard and Area Cleaning

- Clean the inside of the guard and the surrounding area with a soft cloth to prevent dust buildup, which can be a fire hazard and impair cooling.
- Note: Do not use the guard as a step or a support for tools.

Task 4: Reinstallation of Guard

- Ensure the area around the belt is clear.
- Carefully reposition the guard and secure all fasteners tightly.
- Gently attempt to move the guard to confirm it is firmly attached and does not vibrate.

5) Maintenance Quick-Reference Guide

Weekly / Pre-Use Inspection

- Power off machine
- Check guard is securely fastened
- Look for obvious damage
- Verify no unusual noises or vibrations

Monthly / Quarterly Maintenance

- Perform Lockout/Tagout (LOTO)
- Remove guard and inspect belt
- Clean guard interior and surrounding area
- Reinstall guard securely

Annual / Professional Service

- Schedule full inspection by trained technician
- Verify compliance with safety standards
- Review and update operator training records

6) Compliance & Standards

The design and use of the guard must align with safety standards:

- SHA 1910.212: Requires the belt driven axial fan have guards to protect operators from moving parts.
- BS EN ISO 13857:2019: Provides guidelines on safety distances to prevent reaching hazardous areas (like belts and pulleys) and emphasizes proper guarding.

7) Training Requirements

All operators and maintenance personnel must be trained on:

- The severe hazards of rotating fan components.
- The purpose and importance of the belt guard.
- How to perform the visual inspections outlined in Section 3.
- The absolute requirement for LOTO procedures before any guard removal or maintenance task.

8) Emergency Actions & Reporting

- If the guard is damaged or missing: IMMEDIATELY take the fan out of service. Do not operate. Report to your supervisor and attach a clear "DO NOT USE" tag.
- If you hear unusual noises (squealing, knocking): Stop the run immediately, let the fan impeller come to a complete stop, and investigate. Report the issue.
- If a belt fails during operation: Power down, follow LOTO, and inspect for collateral damage. Replace with a manufacturer-approved belt.

8.5 Operation at higher temperatures (> 70 deg. C) / Smoke proof design F200 / F300 / F400 (EN 12101-3)

For fans designed for operation at higher temperatures, precautions against the touching of hot surfaces (e.g. safety guards, warning signs) must be taken. In case of cold starts, the power consumption could possibly exceed the design value and the current consumption could increase to inadmissibly high values. This is especially the case when centrifugal fans are not started against a closed flap. Careful observation of the start-up is required. The user has to secure that the cable that he inserts into the terminal box is suitable (attention if the fan unit is installed on AV mounts) and heat resistant. According to the temperature requirements, the wires inside the terminal box have to be isolated with additional glass fiber sleeve. The cable should not touch the fan casing and must be protected against mechanical damage.

Before the fan is switched off, it should be operated for some time at low gas temperatures (<100°C) until the impeller, shaft and housing have cooled down. This is to prevent heat from adversely affecting the bearings or grease at standstill. Also, the shaft shall be turned until it has cooled down, to prevent warping of the warm shaft. The rules for correct distance away from flammable equipment must be respected at all times.

Attention: Check bearing grease in case of accidental interruption. It can liquefy or possibly leak out.



When using cooling discs for higher temperatures, it should be noted that adequate cooling is achieved only when the speed of rotation is sufficient. At higher impeller temperatures and low speeds (e.g. frequency converter) or when stopped (e.g. emergency stoppage or power failure), the user must cool the cooling disc externally, e.g. with a separate fan with a secured power supply.

8.6 Electrical Motor and its connection

Electrical connection

All work must be carried out only by **qualified** technical personnel on the **idle** low voltage machine in visibly **activated** state **secured against restart**. This is applicable even for auxiliary circuits (for e.g. standstill heating). **Check whether the system is disconnected!**

Adhere to specifications on the rating plate as well as the wiring diagram in junction box. Exceeding the tolerances in EN 60034-1/DIN VDE 0530, Part 1 - Voltage $\pm 5\%$, Frequency $\pm 2\%$, and also unfavorable curve shape or missing symmetry - increases the heating and influences the electromagnetic tolerance. The connection must be undertaken such that a **permanent, secure** electrical connection is obtained (no dangling wire ends); use dedicated cable ends. Make **ground wire connection**.

The smallest air gaps between blank, live parts and against earthing should not be less than the following values: 8 mm for UN ≤ 550 V, 10 mm for UN ≤ 725 V, 14 mm for UN ≤ 1000 V. The junction box must be free from foreign bodies, dirt and humidity. Close cable glands that are not used and the box such that they are **dust-and water-proof**. Secure **half keys** for trial run without downthrust elements. **Check** the smooth functioning of brakes for low voltage machines with **brakes** before commissioning.

Operation

In some cases, higher values are to be expected, refer to ISO 14 694. In case of changes compared to the normal operation - for e.g. **increased temperatures, noises, vibrations** - the cause must be established, if necessary, referring to the manufacturer. Safety devices should not be disconnected even in trial operation. Switch off fan in **case of doubt**. Clean the air passages regularly if dirty. Regrease bearings with regreasing device when motor is **running**. Adhere to type of lubrication! In case the grease outlet bores are closed with stoppers (IP 54 Shaft side: IP 23 Shaft side and cooling side), **remove stoppers** before greasing and then close again thereafter. Bearings must be replaced in case of continuous lubrication (2Z-bearing) after about 10,000 hours (2 pole) or after 20,000 hours (higher-poled) or according to the specifications of the manufacturer.

Minimum speed / maximum speed

If a fan has been designed for speed-controlled operation, **the minimum speed** should not be less than **30% of the nominal speed**. If lower speeds are required for the system, special permission (= recalculation of drive motor/ checking the bearing) is required for the same.

Starting / Stopping / Reversing

Due to high moment of inertia of fan- impellers, a fan may be started, stopped or reversed maximum 4 times in an hour. At least a time span of 2 minutes must be maintained between two subsequent switching processes. If higher switching cycles are required for the system, special permission (= recalculation of drive motor/ checking the drive motor) is required for the same.

Transport, storage

Damages found must be reported immediately to us. The commissioning may be delayed. Tighten the screwed transport bolts securely. They are designed according to the weight of the low voltage machine and do not apply additional loads. Remove transport fastenings before commissioning. Re-use for further transports. If low voltage machines are stored, ensure dry, dust-free and vibration-free environment ($V_{eff} \leq 0.2$ mm/s). Measure the insulation resistance before commissioning. Dry the winding for values $\leq 1k\Omega$ per Volt of measured voltage. Follow the "Storage instructions".

8.7 Vibration Monitoring

For safe operation, installation of vibration sensors are always recommended.

The increase of vibration level is always a dangerous signal.

The change of vibration can be monitored by measuring the mechanical vibration of the bearing and motor.

The continuous vibration value measured can be well monitored. Through long-term vibration monitoring, the change of fan operating conditions can be found at early stage and can be corrected if necessary. As such the equipment damage can be avoided and necessary maintenance work can be planned economically and effectively.

If there are any significant changes on the vibration value, the causes can be checked ie improper installation, dirt accumulation, wear on the impeller or other components etc.

The vibration may be caused by motor misalignment, rotor imbalance, bearing defects, greasing or lubrication problems, etc

For fans, vibration can be due to unbalance, blade through frequency, turbulence, motor, belt drive, belt natural frequency, base mounting isolator etc

NB: Vibration severity range limits (ISO 2372) and balance and vibration application categories (ISO 14694)

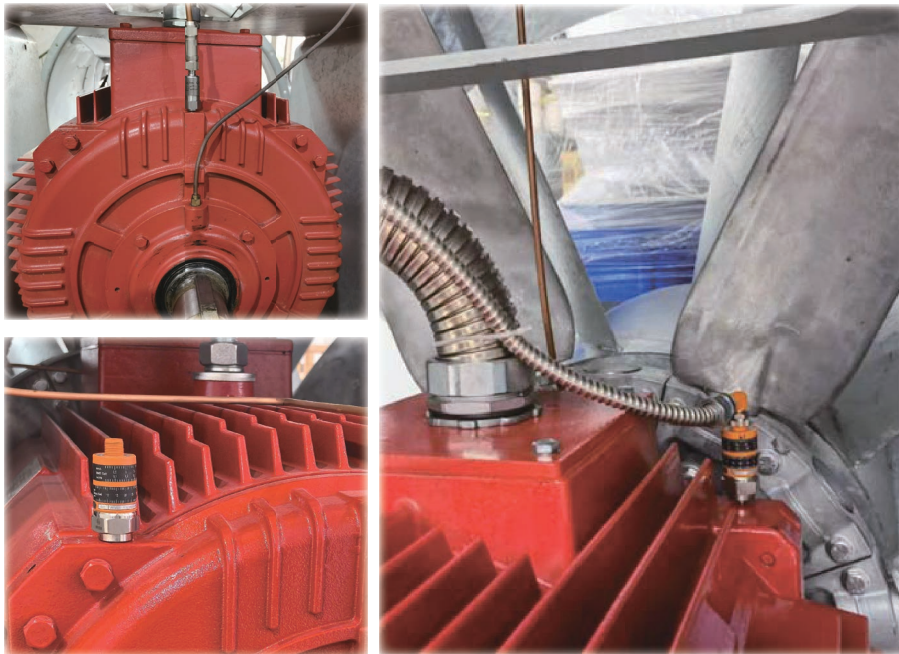

Note: Vibration Sensor should be installed at top of motor at drive end in vertical direction between -45 degree and +45 degree.

9 Commissioning checklist

Name of Project / Machine Number:	Maintenance No.	
	EXAMINER	DATE
JOB STEPS		
First inspection		
- Inspection of transport damages		
- Inspection of completeness		
Inspection after mounting		
- flexible connection not damaged		
- Vibration damper correctly adjusted		
- Secure erection guaranteed		
- All damages to paint rectified		
- All basic safety instructions considered		
Inspection during commissioning		
- All basic safety instructions considered		
- Functioning of bearing status analysis checked		
- Functioning of fluctuation monitoring checked		
- Direction of rotation checked		
- Vibration values of bearing or motor measured. acc. to ISO 14694/ ISO 10816-3 horizontal / vertical / axialmm/s mm/s mm/s		
- Sound pressure level measured (1 - 3m / 45° removed from suction)dB(A)		
- Operation on frequency converter (yes / no / TYPE of FC)		
- Electrical values measured Voltage / FrequencyV / Hz Current Phase U / V / W A / A / A		

Note: If in doubt, please contact WOLTER local representative for assistance.

10 Status - and maintenance checklist

Name of Project / Machine Number:	Maintenance No.	
	EXAMINER	DATE
WORKING STEPS		
Maintenance (at least every 6 months)		
- Bearing status checked/ re-greased		
- Flexible connections checked for leakage		
- Vane controller- movement of blades checked		
- Vibration values of motor B-bearing measured acc. to ISO 14694/ ISO 10816-3 horizontal / vertical / axialmm/s mm/s mm/s		
- Vibration values of casing measured acc. to ISO 14694/ ISO 10816-3 horizontal / vertical / axialmm/s mm/s mm/s		
- Sound pressure level measured (3 m / 45° removed from suction)dB(A)		
- Electrical values measured voltage / Frequency.....V / Hz Current Phase U / V / W A / A / A		
- Visual check for corrosion (possible rectification of paint damages) - Blower - Vibration damper - Impeller		
- Visual check for corrosion - Motor		
damages checked - Blower - Vibration damper - Impeller		
- Insulation measurement at wrm motor (Resistance winding –mass with 500 V DC voltage) MegaOhm		
- In case stainless steel-blower / -silencer -> All deposits of corroded particles on the surface removed		
- Functioning of fluctuation observation checked Read-off values horizontal / vertical / axial mm/smm/smm/s		
E-Kit of tear-off –safety checked		

Note: If in doubt, please contact WOLTER local representative for assistance.

11 Instructions regarding special types of dangers

11.1 Electrical energy

Use only original fuses with specified current rating! Switch off the machine/plant immediately in case of interruptions in the electrical power supply!

Work on electrical devices or equipment must be undertaken only by a skilled electrician or by instructed personnel under the supervision of a skilled electrician in accordance with the electro-technical rules.

Machine parts must be disconnected if inspection, maintenance and repairs must be undertaken– if prescribed. The de-energized parts must be inspected first for disconnection, then, ground them and short-circuit them and also insulate live parts!

Inspect/ check electrical equipment of machine regularly. Defects such as loose connections or scorched cables, must be rectified immediately.

If work is required on live parts, a second person who can activate the emergency-off- or main switch in case of emergency needs to be around and involved. Secure work area with a red-white safety chain and warning sign. Use only insulated tools!

Connect the feeder cable to the ground while working on high voltage components after cutting off voltage and short-circuit the components, for e.g. capacitors with a grounding rod!

Tightening torque for electrical terminal boards (values) in Nm:		
bolts		starting torque in Nm
thread <i>d</i>	material	
M4	CuZn37 F45	1,2
M5		2
M6		3
M8		6
M10		10
M12		15,5
M16	CuZn37 F38	30
M20		52
M10	E - Cu57 F25 oder E - Cu58 F25	10
M12		15,5
M16		30
M20		52
M24 x 2		80
M30 x 2		150
M33 x 2		197
M36 x 2		252

Table 7 Tightening torque for electrical terminal boards

11.2 Gas, dust, steam, smoke

Welding, frame cutting and grinding work on the machine can be undertaken only if permission has been given explicitly.

There is risk of fire and explosion!

Before welding, frame cutting and grinding, the machine and its surroundings must be cleaned, free from dust and combustible material and ensure sufficient ventilation (Risk of explosion)!

Observe all national regulations if work have to be carried out in narrow rooms!

11.3 Hydraulics, pneumatics

Only trained personnel with special knowledge and relevant experience in hydraulics must undertake work on hydraulic equipment!

All pipes, ducts and connections have to be inspected regularly for leakage and obvious damages! Rectify damages immediately! Splashed oil can lead to injury and fires.

Depressurize all system sections to be opened and pressurized pipes (hydraulic, compressed air) before beginning repair work according to the descriptions of components!

Lay hydraulic and compressed air pipelines properly before mounting them! Do not interchange connections! Armature, length and quality of pipelines must comply with the requirements.

11.4 Noise

All sound-protecting devices on the machine must be in closed position during the operation.

Wear prescribed ear protection!

11.5 Oils, grease and other chemical substances

When handling oil, grease and other chemical substances, adhere to the safety instructions applicable for the product!

Caution while handling hot equipment and auxiliary material (risk of burning or scalding)!

11.6 Portable machines (Machines used at different locations)

Use only hoists and load suspending devices with sufficient lifting capacity during loading work!

Appoint an expert for the hoisting work!

Lift machines properly with hoists only in accordance with the specifications of operating instruction manual (fixing point for load suspending devices etc.)!

Use only suitable transport vehicle with sufficient lifting capacity!

Ensure reliable loading. Use suitable fixing points!

Equip machine with recommended/supplied devices against unintentional change in position before or directly at the end of loading work! Put up appropriate warning sign!

Properly remove devices before re-commissioning!

Carefully re-mount the parts that were dismantled for transport purposes before re-commissioning and fix them!

Disconnect the machine or plant from any external energy supply even for minor changes in location! Connect the machine properly to the mains again before re-commissioning!

Proceed in accordance with the operating instruction before re-commissioning!

Sales Network

Deutschland

Wolter GmbH.
Maschinen-und Apparatebau KG.
DE-76316 Malsch
T +49 (0) 72 04 / 92 01 0
F +49 (0) 72 04 / 92 01 11
info@wolter.eu

Europe

Denmark:

L.ØLAND VENTILATION A/S
DK-2605 Brøndby
T +45 (0) 70 / 20 19 11
salg@airforce.dk

Netherlands:

DE WIT Ventilatoren BV
NL-3821 CG Amersfoort
T +31 (0) 33 / 76 00 240
info@dewitventilatoren.nl

Sweden:

Nordisk Ventilator AB
SE-142 50 Skogås
T +46 (0) 8 / 72 70 250
se@nordiskventilator.se

Switzerland:

Anson AG Zürich
CH-8055 Zürich
T +41 (0) 44 / 46 11 111
F +41 (0) 44 / 46 13 111
info@anson.ch

OZ Tech SA

CH-1122 Romanel-sur-Morges
T +41 (0) 76 / 41 11 572
info@oztech.ch

United Kingdom:

Wolter (UK) Ltd.
GB-Leicestershire LE65 1AL
T +44 (0) 15 30 / 41 24 73
info@wolteruk.com

Middle East

UAE, Saudi Arabia, Qatar, Lebanon:

Please contact Wolter head office

Wolter GmbH.

Maschinen-und Apparatebau KG.
DE-76316 Malsch
T +49 (0) 72 04 / 92 01 0
F +49 (0) 72 04 / 92 01 11
info@wolter.eu

Asia

China:

Guangdong Wolter Chemco Ventilation Ltd.
Boluo, Huizhou, Guangdong

Dongguan Wolter Chemco Ventilation Ltd.

Shipai, Dongguan, Guangdong
T +86 (0) 769 / 8655 7298
F +86 (0) 769 / 8655 7278
info@wolter.com.hk

Taizhou Wolter Ventilation Co. Ltd.

Hengjie, Luqiao District,
Taizhou, Zhejiang
T +86 (0) 576 / 26 22 666 (26 52 888)
F +86 (0) 576 / 26 56 830

China - Hong Kong, Macau:

Wolter Asia Ltd
Kowloon, Hong Kong
T +852 (0) 2456 0198
F +852 (0) 2456 0290
info@wolter.com.hk

China - Taiwan:

Waxlink International Co., Ltd.
8F-2 No.218 Roosevelt Rd.,
Sec.6, Taipei, Taiwan
T +886 (0) 2 / 8932 1196
F +886 (0) 2 / 8932 1197
waxlink@mail.waxlinktw.com

India:

Wolter Ventilators India Pvt. Ltd.
867 D, Block-A, Sushant Lok, Phase-I,
Gurgaon - 122009 (Haryana)
T +91 (0) 124 2577797, 4261001-3
sales@wolterindia.in

Korea:

Kaceco-Wolter
14-1, Dang-dong, Gunpo-shi,
Gyeonggi-do
T +(82) 0 31 / 4773 104
F +(82) 0 31 / 4773 132
wolter@kaceco.com
info@kaceco.com

Malaysia:

Vibrantech (M) Sdn Bhd.
47200 Petaling Jaya Selangor
T +603 (0) 7847 3500
F +603 (0) 7847 3380
sales@vibrantech-sb.com

Singapore:

Wolter Pte. Ltd.
SG-569738 Singapore
T +65 (0) 63 / 52 95 48
F +65 (0) 63 / 52 95 47
info@wolterfans.com.sg

Thailand:

Wolter Ventilation Co., Ltd.
Thamai Kratumban Samutsakorn
741 10 Thailand
T +66 (0) 84 555 2936
kongsakol@wolterfan.com

Australia

The Sydney Fan Company.
NSW 2147, Sydney, Australia
T +61 (0) 2 / 9624 4000
F +61 (0) 2 / 9624 4100
sales@thesydneyfancompany.com

Wolter GmbH Maschinen-und Apparatebau KG

Am Wasen 11
DE-76316 Malsch / Germany
T +49 (0) 72 04 / 92 01 0
F +49 (0) 72 04 / 92 01 11
www.wolter.eu
info@wolter.eu





Reference: Operating Instruction **MA09**, V2024/January Printed in January 2024

Wolter Asia Ltd.

Unit A4, 3rd floor, Merit Industrial Centre, No.94 To Kwa Wan Road, Kowloon, Hong Kong
Tel. +(852) 2456 0198; Fax +(852) 2456 0290; www.wolter.com.hk; info@wolter.com.hk

Guangdong Wolter Chemco Ventilation Ltd.

Jigongkeng Administrative Zone, Futian, Boluo, Huizhou, Guangdong, P.R.China
www.wolter.com.hk; info@wolter.com.hk

Dongguan Wolter Chemco Ventilation Ltd.

No.69, Miao Bian Wang Road, Shipai, Dongguan, Guangdong, P.R.China
Tel. +(86) 0769 8655 7298; Fax +(86) 0769 8655 7278