

Tunnel Axial Fans

- Uni-Directional Series
- Reversible Series

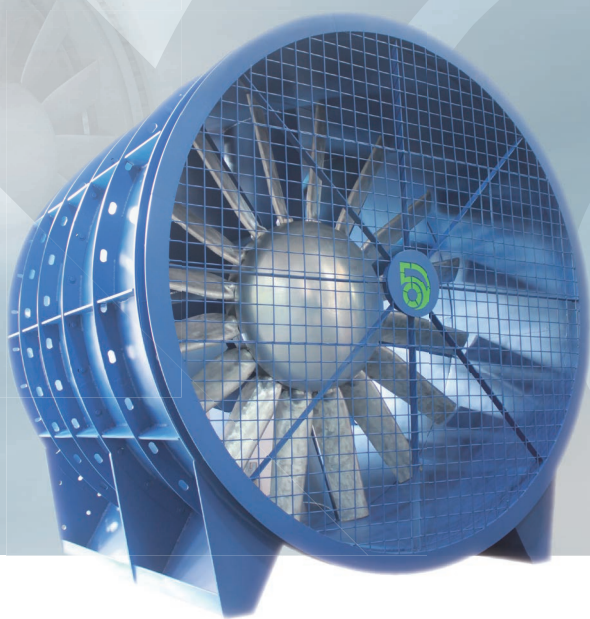
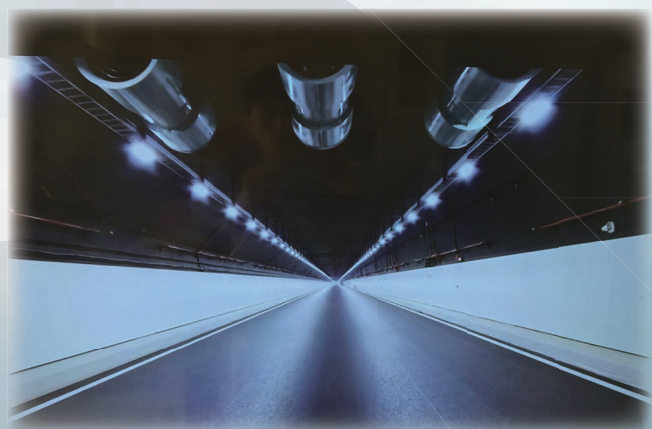

A11

wolter 

Tunnel Axial Fans

Technical Description

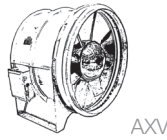

Fan type code

AXV 800 - 250 - 9 / 20° - F LH - 2 DD SU 250°C/2

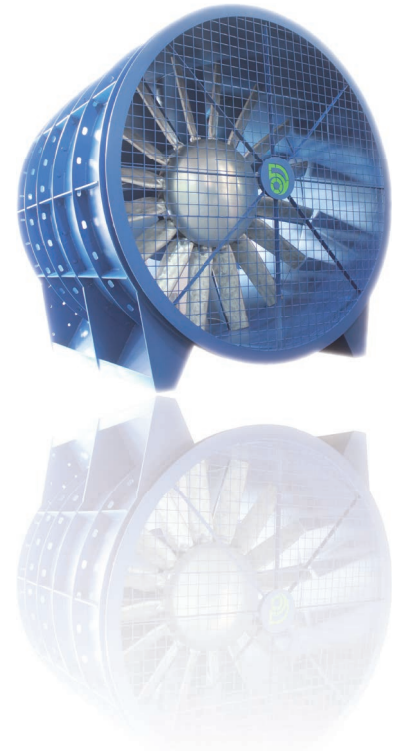

Design features

Types and duty range

AXV (Former named AXD) or AXV ... R (Former named RXD) Tunnel axial flow fans are specially manufactured for all applications and mounting positions in case sizes 315 up to 3,150 mm diameter.

The performance range is from 1,000 up to 1,100,000 m³/h on air volume, at static pressure up to 3,000 Pa (or total pressure up to 3,500 Pa). Higher pressures are possible on multi-stage versions.

Versions

There are 3 versions for different fields of application:

- AXV (H) heat exhaust fan (UPE/OTE fan in the metro)
- AXV (S) fire smoke discharge fan (smoke fan in the metro)
- AXV (V) ventilation fan (fresh air fan in the metro)

Type	AXV (H)	AXV (S)	AXV (V)
Fan Size	1,000 - 2,400 mm	800 - 2,400 mm	500 - 3,150 mm
Blade Angle	stationary blade adjustable ranging from 8° to + 40°		
Max. air temp. and cont. operating time	250°C, 300°C, 400°C / 1 or 2 hours;		< 45°C

Connecting duct

Rubber flexible duct is available for connecting the fan to the duct, or diffuser is applied on the client's demands.

Arrangement style

There are four arrangement style, i. g. vertical, horizontal, hanging and wall arrangement according to the requirement of ventilation system. For hanging arrangement, size 1600mm or lower is available or the power of motor shall be lower than 75kW. For the motor power of the wall arrangement fan shall be lower than 22kW.

Motor speed

According to the requirement of ventilation system, single speed or dual speed motor is applied, as well as frequency conversion device.

Remarks

The vibration absorber with the different load is available for AXV series axial fan with large size or higher speed;
Three types of AXV series fan can selected from the same performance parameters sheet and performance curve.

Structure and arrangement

The fans supplied as a complete unit consisting of impeller, motor, casing, guide vane unit, support, vibration absorber and so on. There are two arrangements of horizontal and vertical and two groups of single connection duct and dual connection ducts, referring to the figure 1.

- The impeller composes of hub and blades which has stationary blade adjustable ranging from 8° to + 40°.
- Stationary blade adjustable: the blade angle is adjusted manually after stopping the fan and loosening the bolts on the blade root.
- For motor, insulation class F or H will be applied, and protection classes IP54 and 55 are available. The motors are high temperature resistant and hot/moisture type. The terminal box is mounted on the casing.
- For the design of the impeller section of the casing, to be sure the radial clearance of the blades and minimise the length and weight.

Tunnel Axial Fans

Technical Description

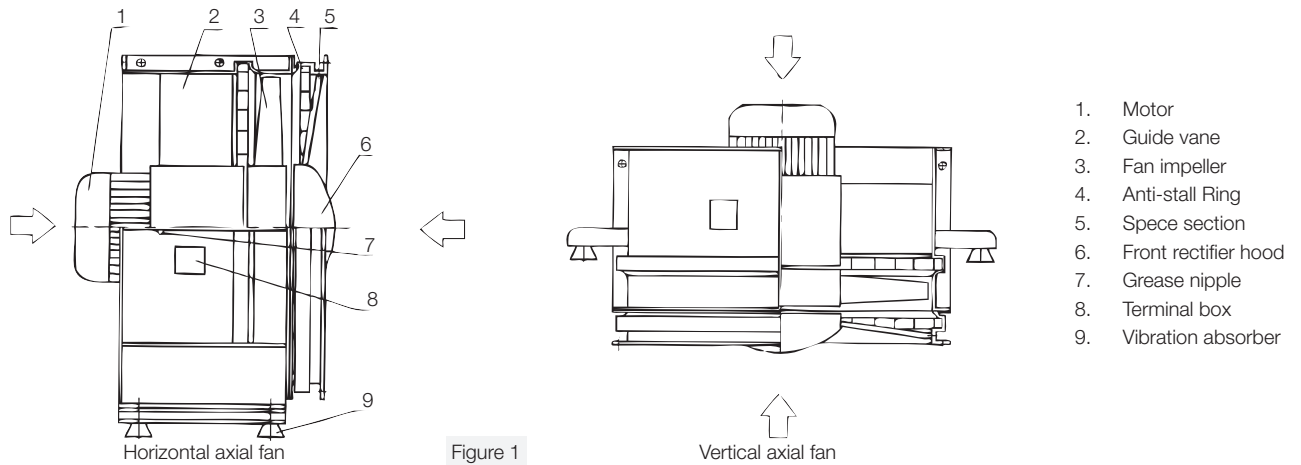
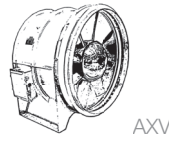

1. Motor
2. Guide vane
3. Fan impeller
4. Anti-stall Ring
5. Spece section
6. Front rectifier hood
7. Grease nipple
8. Terminal box
9. Vibration absorber

Figure 1

- To make the fan as compact as possible and maximise the efficiency, the guide vane, bell mouth and guide vane unit are the static parts.
- Anti-surge system mounted is to prevent the surge caused by the over-speed operation of the fan to ensure the stable operation during long-term period time, especially safety and reliable operation under the conditions of the blocked duct or silencer is or the emergency.
- Vibration absorber is designed and calculated according to the fan weight, linear velocity and dynamic load of the blade.

Characteristics of the AXV tunnel axial fan

High efficiency

To apply the newest aviation aerodynamic design technology, repeat test and inspection and prove the characteristics of high efficiency, wide high-efficiency range and equal efficiency between clockwise and counter clockwise rotation.

Low noise

To reduce the aerodynamic noise of fan and minimise the whirlpool loss in the tip of blade and blade root.

Wide application

AXV or AXV...R axial fan is equipped with corrosion resistant, moisture proof, high insulation degree, hot and humid type and high temperature resistant motor. So the fan is used for ventilation (exhaust) in the ventilation system of metro and tunnel, as well as in the fire smoke discharge system under the emergency conditions for 250°C, 300°C or 400°C on continuous operation for 60 minutes or up to 120 minutes according to EN 12101-3.

High strength

Blades are cast in aluminium alloy. There is good radial structure for the aluminium alloy blades and hub. The thermal expansion factor of the fan impeller and casing detected by X ray is considered under the temperature of 400°C to ensure the strength of impeller and high speed operation.

Compact structure

To make the fan as compact as possible, fan blade and guide vane device is designed to minimise the fan casing length. The casing and support are made the finite element calculation to ensure the specific conditions for metro.

Short switching time

Being utilised the energy consumption to stop, it is proved that the operation direction of the fan will be conversed and reach to the rating speed within 30 seconds. Good corrosion resistant Fan casing is hot dip galvanised. Motor is hot and humid type. Fan blades and hub is made of aluminium alloy.

Stable operation

Fan impeller is balanced according to ISO 14694 balance quality grade G2.5. Over-speed test of the impeller, vibration test of the complete fan and aerodynamic performance test to reach the requirements of high speed stable operation prior to the factory.

Anti-stall

Tunnel Fans are very often subjected to severe aero-dynamic loads in the form of pressure transients generated by train movement in the tunnel. The range fans equipped with anti-stall ring (anti-surge system) is to prevent the surge under the emergency conditions in the tunnel so that the surge alarm device is not necessary.

Anti-Stall ring diverts and stabilizes turbulent air streams and returns them to the direction of the main air flow. An ANTI-STALL Fan will ensure stable operation under all conditions (see Fig.2).

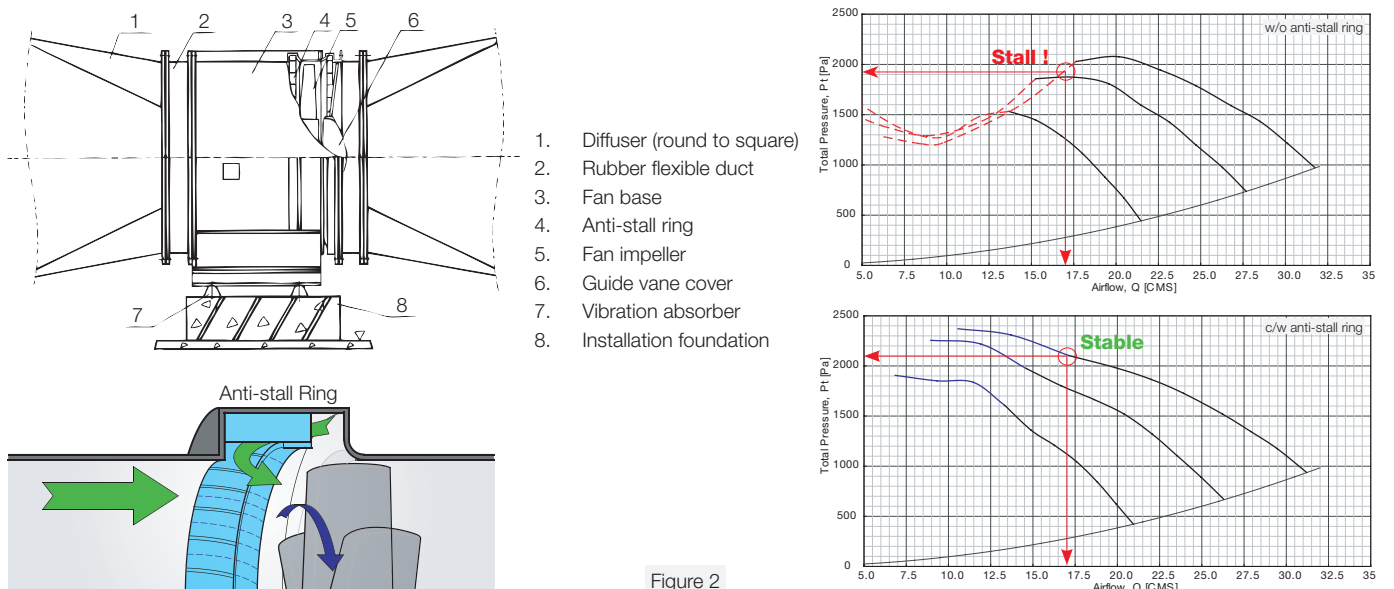
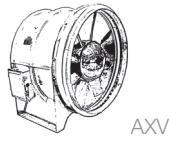

Figure 2

Tunnel Axial Fans

Technical Description



Installation sketch for AXV series tunnel fans

Horizontal arrangement for AXV series tunnel fans (refers to Fig. 3)

- The length of the foundation embedded steel sheet is $(L + 100)$ or more, width is $((B2 - B1)/2 + 20)$ or more.
- For the fan weight without motor and overall dimension, please refers to the overall dimension drawing.

Fan with single connecting ducts

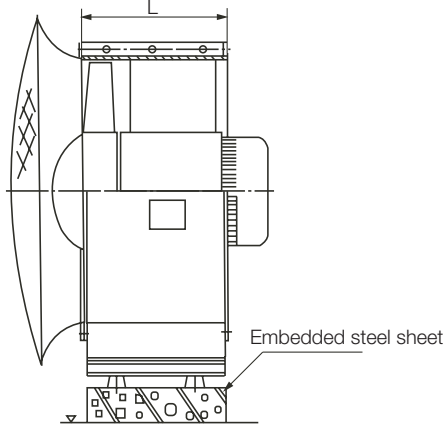
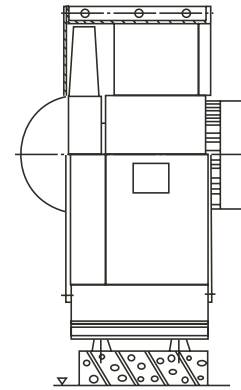

Figure 3

Fan with dual connecting ducts



Vertical arrangement for AXV series tunnel fans (Circular Platform Opening as per Fig. 4a, Square Platform Opening as per Fig. 4b)

- For the fan weight without motor and overall dimension, please refers to the overall dimension drawing.
- H value is showing in the following table.

Fan with single connecting ducts

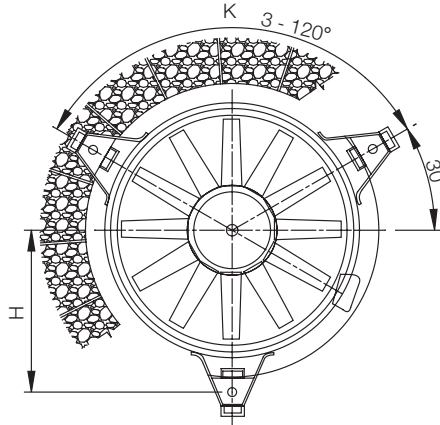
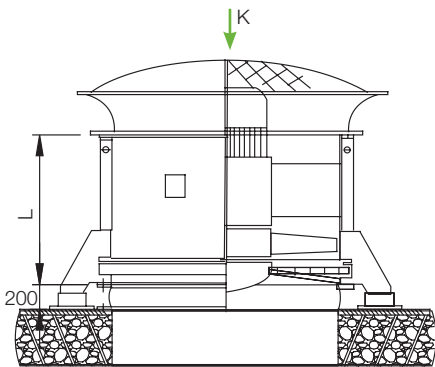
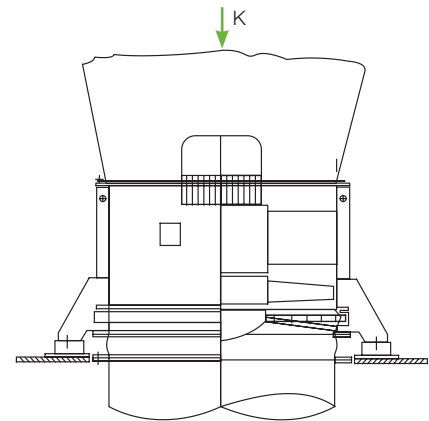

Figure 4a Circular Platform Opening

Fan with dual connecting ducts



Fan with dual connecting ducts

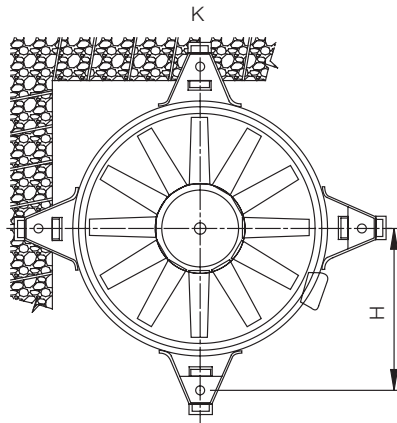
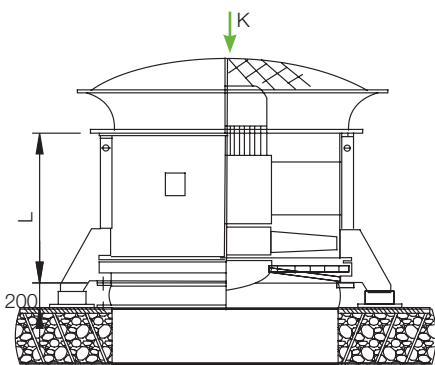
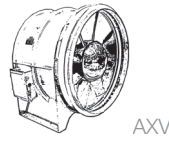

Figure 4b Square Platform Opening

Size	1250	1400	1600	1800	2000	2200	2400	2500	2600	2800	3150
H (mm)	840	965	1065	1160	1260	1410	1510	1580	1650	1750	1930

Tunnel Axial Fans

Technical Description



Hanging arrangement for AXV series tunnel axial fan (refers to Fig. 5)

- For fans with motor power exceeding 75 kW, hanging arrangements are not advisable.
- h value shall be determined according to the layout of the air duct in the ventilation system, referring to the installation sketch.
- For the fan weight without motor and overall dimension, please refers to the overall dimension drawing.

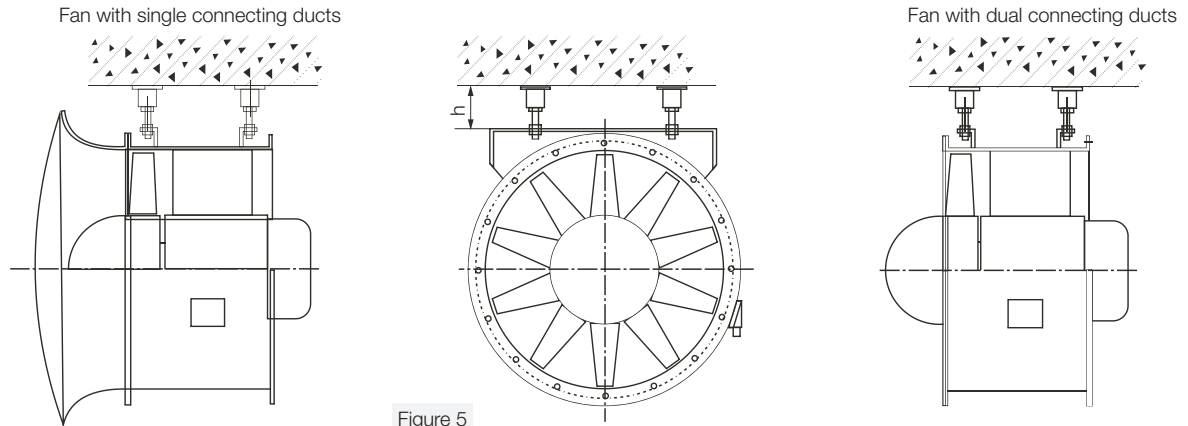

Figure 5

Wall arrangement for AXV series tunnel axial fan (refers to Fig. 6)

- For the wall arrangement, the fan is connecting to single duct or dual ducts.
- For fans with motor power exceeding 22 kW, Wall mounting arrangements are not advisable.
- The length of the plate is more than $(L + 100)$, width of that is more than $(B + 20)$.
- For the fan weight without motor and overall dimension, please refers to the overall dimension drawing.

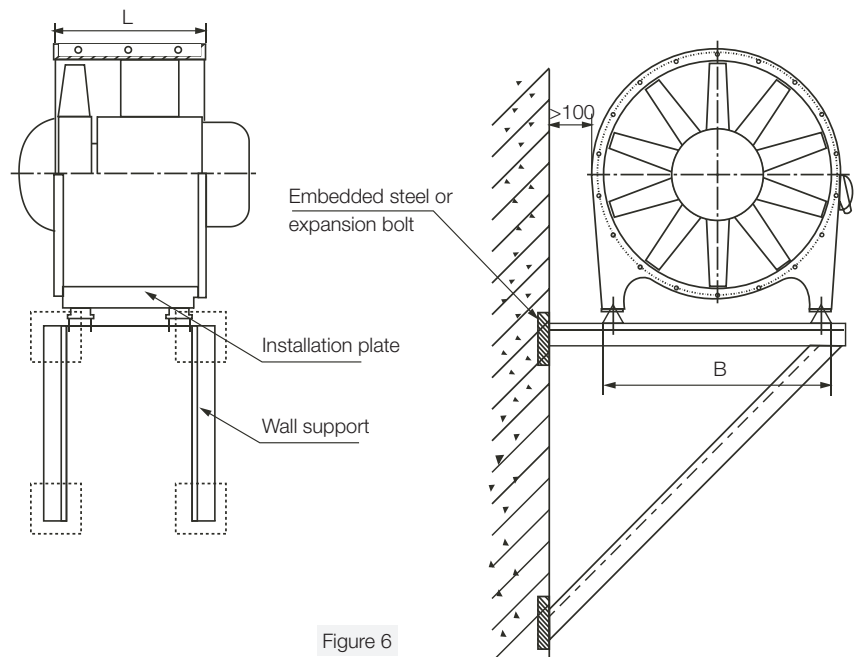

Figure 6

Fan Installation

Installation recommendations are as follows:

- Fans with free inlet and outlet should be installed with $1,5 \times$ fan diameter distance on extract and supply side to next equipment. Fans should have a bellmouth on the air entry to get a smooth airstream. High performance fans will work at higher efficiencies and save energy if diffusers are mounted on the outlet.
- When installing fans into systems and to other equipments (bends by 90 degr., filters, silencers etc) correct bond radius and distance are to be considered to avoid losses. Flexible connectors are to be installed smooth. By not following advices you will lose performance. (see pictures below).

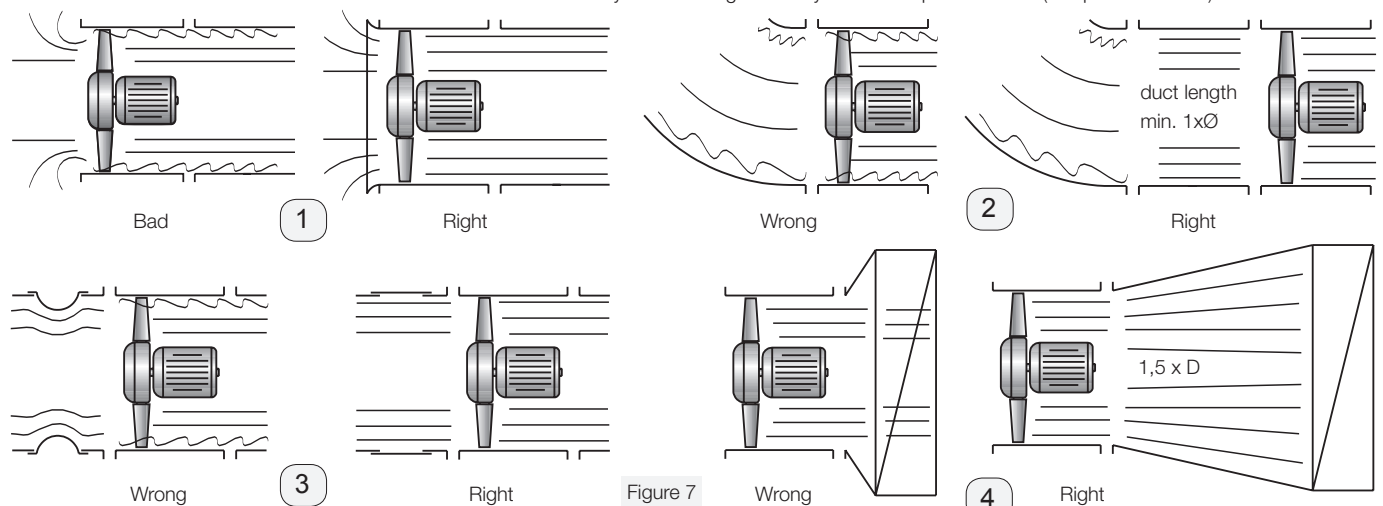
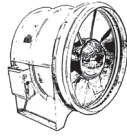

Figure 7

Tunnel Axial Fans

Technical Description



AXV



Selection example

Required duty point

- Volume flow : 5,000 m³/h
- Static pressure: 110 Pa
- Fan speed: 1,440 1/min (4-pole)

In order to calculate the total pressure, please add velocity pressure to static pressure (30 Pa dynamic pressure + 110 Pa static pressure = 140 Pa total pressure)

Using the fan curve

Having chosen a fan with adequate performance range for the required duty point, plot volume flow and pressure.

At the point of intersection, the following data can be read:

- Motor speed or number of poles 1,440 1/min - 4 pole
- Pitch angle: 18 degrees
- Inlet sound power level: 77 dB(A) if use of unlined metal duct

Calculation of motor power:

Having chosen a fan with adequate performance range for the required duty point, plot volume flow and pressure.

There are two possibilities to calculate the motor power:

- Calculation of absorbed power by using the fan curve in duty point: 0.338 kW,
Motor power: 0.37kW
- Calculation according to peak absorbed power, see table below the fan curve: 0.366 kW,
Motor power: 0.37kW

The given peak absorbed power is the maximum shaft absorbed power over the whole pitch angle curve in.

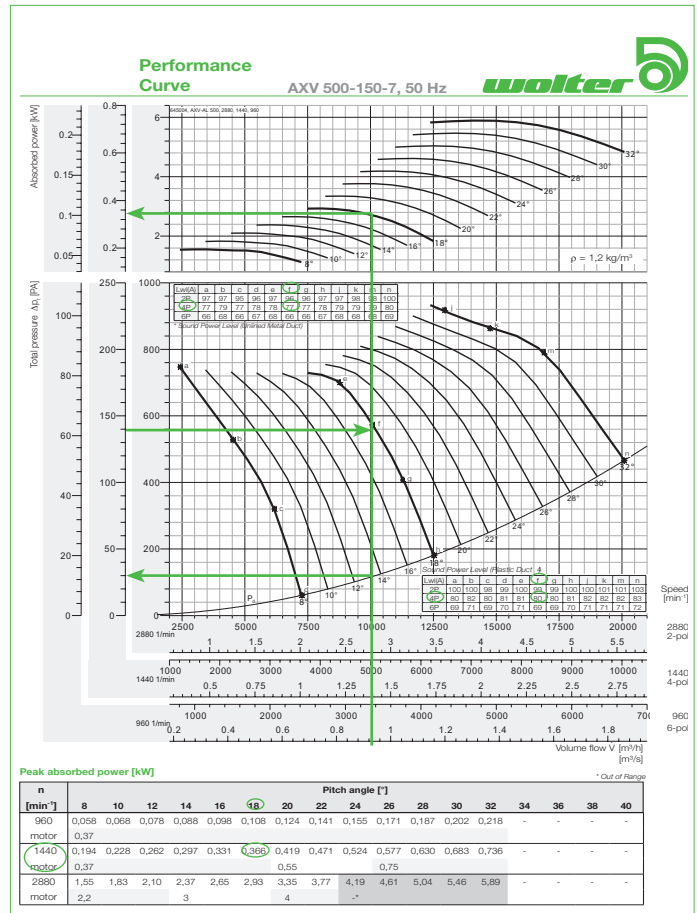

Figure 9

Acoustic and noise control

Sound power levels

This term refers to the power which a source radiates as sound. Sound power levels are expressed in decibels with a reference level of 1 picoWatt. The sound power level of a source remains the same regardless of its environment and the distance to the listener.

If the sound power frequency spectrum is needed, for as follows: example, the design of sound attenuators, the A-weighted rated sound power levels at particular octave band frequency L_{WA} can be calculated by subtracting the relative sound L_{wrel}

$$L_{WA} = L_{wi} + L_{wrel}$$

Sound pressure level

These are pressure fluctuations generated by a source expressed in decibels with a reference level of 20 μPa. The sound pressure level varies with the distance of a sound source to the listener and its environment.

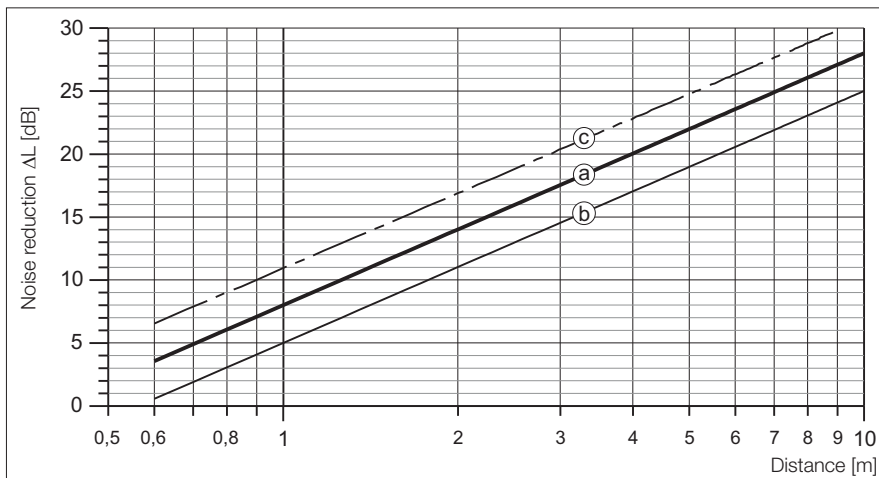

Figure 10

Sound level reduction half sphere

- a: without reflexion
- b: with reflexion
- c: full sphere without reflexion

Frequencies

Sound is split into different frequencies. Frequencies of human hearing range from about 20 cycles per second (Hz) to 20,000 cycles per second (Hz). For practical purposes, Wolter publishes noise data in eight octave bands with the centre frequencies of

(63,) 125, 250, 500, 1,000, 2,000, 4,000 and 8,000 Hz.

Each fan has its own specific correction factor which is to be deducted from sound power according to the octave band.

Tunnel Axial Fans

Technical Description

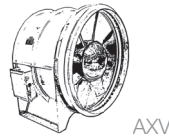

A-weighted sound pressure level in dB (A)

The human ear is more sensitive to sound in some frequencies than in others. The A-weighting is an attempt to reflect this natural perception of sound. The A-weighting is a set of figures which are applied to the sound pressure levels. The levels in each of the octave bands are added logarithmically to give a single figure. The A-weighting over the octave band is as follows:

Table 1)

Frequency [Hz]	63	125	250	500	1000	2000	4000	8000
A-weighting [dB]	-26	-16	-9	-3	0	+1	+1	-1

Example

The dB(A) level of an axial fan AXV 630-9/20° LH-4 (with an impeller diameter of 630mm, 9 impeller blades, 20 degrees pitch angle and a rotational speed of 1.440 1/min) shall be calculated. The fan operates at a duty point of 3,8 m³/s at 50 Pa static pressure. The sound source is situated in 3 metres distance to the listener. The fan performance curve gives a sound power of 87 dB.

63	125	250	500	1000	2000	4000	8000	frequency [Hz]	
87	87	87	87	87	87	87	87	total sound power level	
-5	-6	-5	-6	-7	-10	-15	-21	1) apply specific sound spectrum from fan curve	
-20	-20	-20	-20	-20	-20	-20	-20	2) reduction for 3 m distance (fig. 2)	
-26	-16	-9	-3	0	1	1	-1	3) apply A-weighting as per table 1	
36	45	53	58	60	58	53	45	4) logarithmic addition of sound levels (compare table 2 below)	
46	59	59	62	62	54	54			
59									
64 dB(A)									

Table 2)
Addition of sound levels

Difference between two sound levels [dB]	Add to the higher level [dB]
0 - 1	3
2 - 3	2
4 - 9	1
≥10	0

$$L_{\Sigma} = 10 \cdot \lg(10^{0,1 \cdot L_1} + 10^{0,1 \cdot L_2} + \dots + 10^{0,1 \cdot L_n})$$

where:

L_1 = sound level of a source 1
 L_{Σ} = resulting summation sound level

Summation of several congeneric sound levels

$$L_{\Sigma} = L_1 + 10 \cdot \lg(z)$$

where:

z = number of sources
 L_1 = sound level of a single source
 L_{Σ} = resulting summation sound level

Please note:

Wolter offers a wide range of different silencers for all levels.

Tunnel Axial Flow Fans

Dimensions



SH

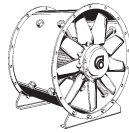

LH

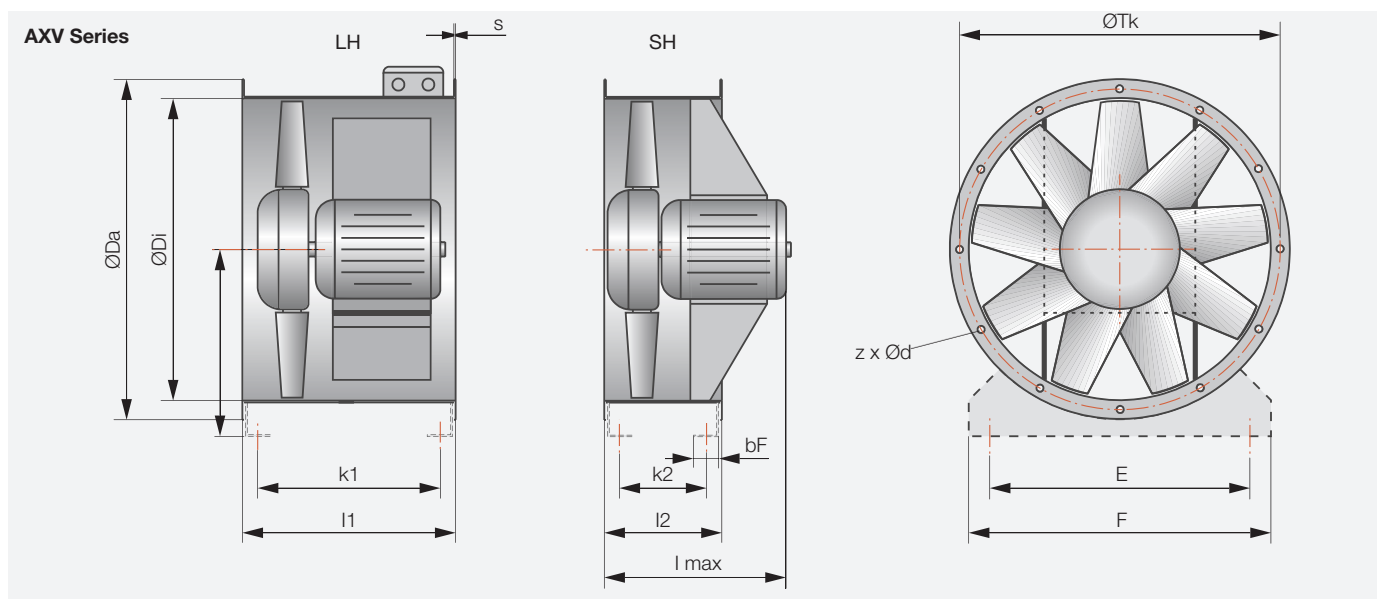

Model size	Da [mm]	Di [mm]	hF [mm]	z x d [mm]	Tk [mm]	E [mm]	F [mm]	bF [mm]
250	306	254	165	8 x 12	286	210	250	60
280	336	282	185	8 x 12	316	240	280	60
315	388	320	205	8 x 12	366	265	315	60
355	428	359	225	8 x 12	405	305	355	60
400	472	401	250	12 x 12	448	350	400	60
450	522	450	280	12 x 12	497	400	450	60
500	574	504	315	12 x 12	551	440	500	70
560	654	565	345	16 x 14	629	500	560	70
630	724	634	400	16 x 14	698	570	630	70
710	802	711	450	16 x 14	775	650	710	70
800	889	797	500	12* x 14	861	730	800	80
900	988	894	580	12* x 14	958	830	900	80
1000	1095	1003	630	12* x 14	1067	930	990	80
1120	1231	1125	690	16* x 18	1200	1050	1110	100
1250	1370	1250	750	16* x 18	1337	1180	1240	100

Model Size	LH/1				LH/2				SH			
	s [mm]	k1 [mm]	l1 [mm]	motor max.	s [mm]	k1 [mm]	l1 [mm]	motor max.	s [mm]	k2 [mm]	l2 [mm]	lmax [mm]
250	2	236	300	80					2	161	225	350
280	2	236	300	80					2	161	225	350
315	2	286	350	80					2	161	225	350
355	2	286	350	80					2	161	225	350
400	2	336	400	90					2	161	225	400
450	2	336	400	112					2	161	225	500
500	2	326	400	112					2	151	225	600
560	2	326	400	112	3	626	700	160	2	226	300	750
630	2	326	400	112	3	626	700	160	2	226	300	750
710	2	325	400	112	3	490	565	132	2	225	300	600
800	3	315	400	112	3	615	700	160	3	215	300	750
900	3	444	530	132	3	614	700	160	3	214	300	750
1000	3	444	530	132	3	694	780	180	3	254	340	800
1120	4	522	630	160	4	708	816	200	4	242	350	800
1250	4	522	630	160	4	708	816	225	4	242	350	800

• We reserve the right to alter measurements without notice in case of technical improvements.

Tunnel Axial Flow Fans

Dimensions

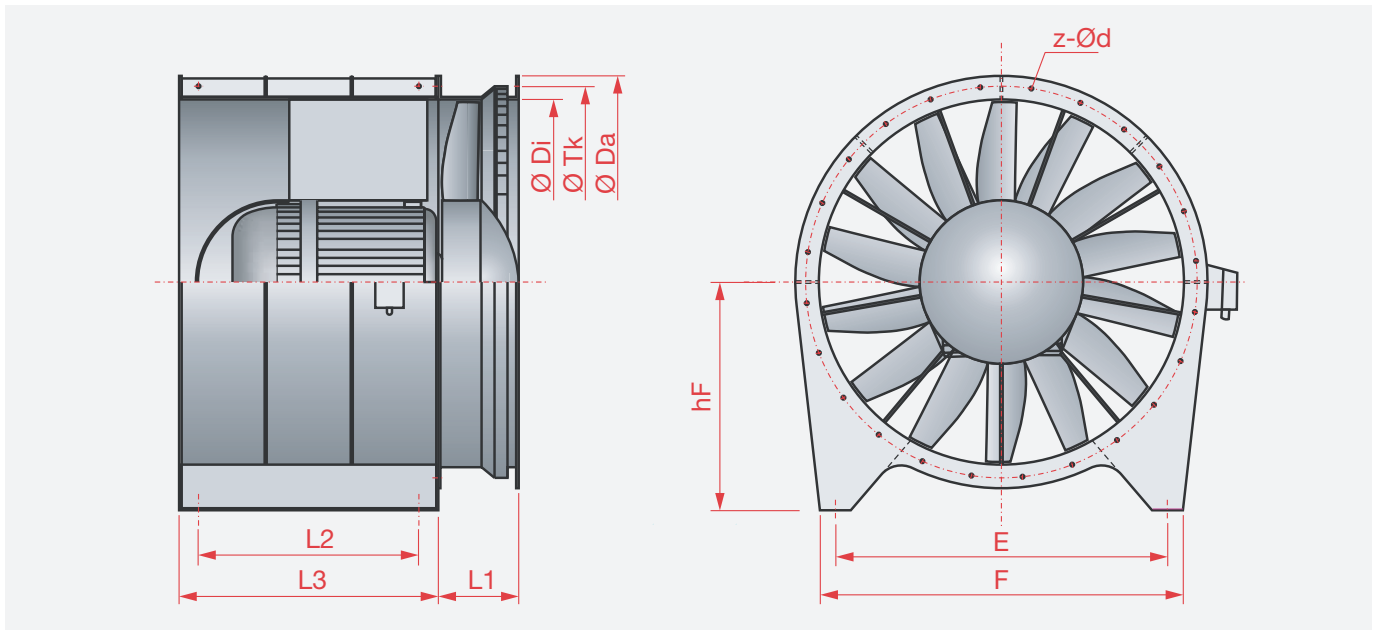

Model Size	Da [mm]	Di [mm]	hF [mm]	z x d [mm]	Tk [mm]	E [mm]	F [mm]	L1 [mm]	L2 [mm]	L3 [mm]
1400	1590	1405	880	20x18	1510	1280	1400	310	850	1000
1600	1790	1605	1050	24x18	1710	1460	1600	355	980	1150
1800	2010	1805	1120	24x18	1920	1660	1800	400	1200	1400
2000	2210	2005	1165	32x18	2120	1820	2000	445	1300	1500
2200	2440	2205	1265	32x18	2340	2020	2200	490	1400	1650
2400	2630	2405	1370	32x18	2530	2220	2400	550	1500	1800
2500	2740	2505	1420	36x24	2640	2320	2500	555	1530	1820
2600	2840	2605	1470	36x24	2740	2380	2600	590	1580	1850
2800	3150	2805	1570	36x24	3000	2500	2800	1300	1680	1900
3000	3375	3005	1670	36x24	3200	2680	3000	1300	1680	1900
3150	3550	3155	1750	36x24	3380	2800	3150	1300	1890	2100

• We reserve the right to alter measurements without notice in case of technical improvements.

ED
Bellmouth inlet

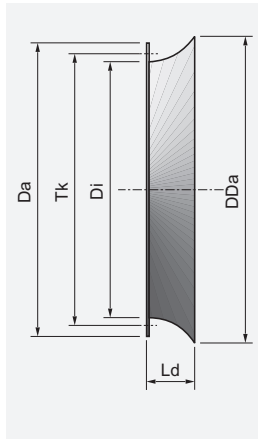

LRK
Air-operated damper

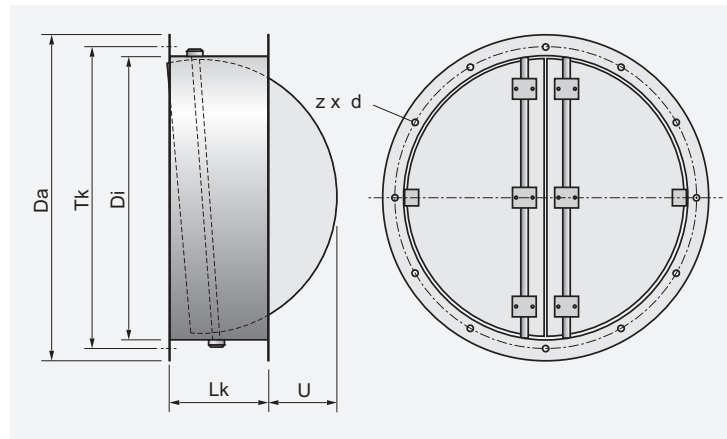

GL-AXV
Matching flange

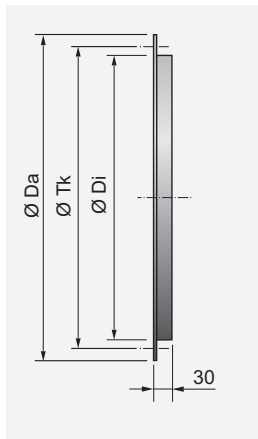

EV-AXV
Flexible connector compl.

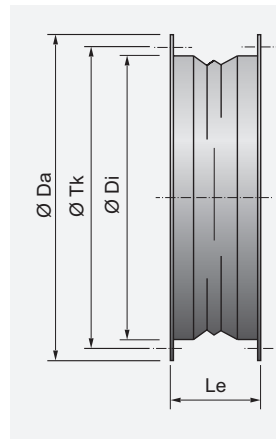

GV-AXV
Up-stream guide vane

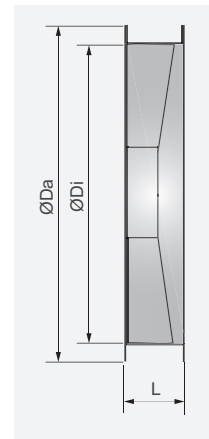

Model size	Da [mm]	Di [mm]	Tk [mm]	z x d [mm]	DDa [mm]	L [mm]	Ld [mm]	Lk [mm]	Le [mm]	U [mm]
355	438	359	405	8 x 12	435	152	165	250	130	-
400	484	401	448	12 x 12	507	152	165	250	130	-
450	534	450	497	12 x 12	555	152	165	250	130	15
500	584	504	551	12 x 12	617	152	165	250	130	45
560	664	565	629	16 x 14	667	152	165	250	130	80
630	734	634	698	16 x 14	757	152	165	250	130	120
710	814	711	775	16 x 14	816	190	170	350	130	60
800	904	797	861	12* x 14	915	190	250	350	130	110
900	1004	894	958	12* x 14	1015	200	250	350	130	170
1000	1105	1003	1067	12* x 14	1115	200	250	350	130	225
1120	1245	1125	1200	16* x 18	1243	240	250	350	130	255
1250	1370	1250	1337	16* x 18	1364	240	250	400	170	375
1400	1525	1405	1475	16* x 18	1523	260	250	400	170	450
1600	1725	1605	1675	20* x 18	1723	260	250	400	170	550

Sales Network

Deutschland

Wolter GmbH.
Maschinen-und Apparatebau KG.
DE-76316 Malsch
T +49 (0) 72 04 / 92 01 0
F +49 (0) 72 04 / 92 01 11
info@wolter.eu

Europe

Denmark:

L.ØLAND VENTILATION A/S
DK-2605 Brøndby
T +45 (0) 70 / 20 19 11
salg@airforce.dk

Netherlands:

DE WIT Ventilatoren BV
NL-3821 CG Amersfoort
T +31 (0) 33 / 76 00 240
info@dewitventilatoren.nl

Sweden:

Nordisk Ventilator AB
SE-142 50 Skogås
T +46 (0) 8 / 72 70 250
se@nordiskventilator.se

Switzerland:

Anson AG Zürich
CH-8055 Zürich
T +41 (0) 44 / 46 11 111
F +41 (0) 44 / 46 13 111
info@anson.ch

OZ Tech SA

CH-1122 Romanel-sur-Morges
T +41 (0) 76 / 41 11 572
info@oztech.ch

United Kingdom:

Wolter (UK) Ltd.
GB-Leicestershire LE65 1AL
T +44 (0) 15 30 / 41 24 73
info@wolteruk.com

Middle East

UAE, Saudi Arabia, Qatar, Lebanon:

Please contact Wolter head office

Wolter GmbH.

Maschinen-und Apparatebau KG.
DE-76316 Malsch
T +49 (0) 72 04 / 92 01 0
F +49 (0) 72 04 / 92 01 11
info@wolter.eu

Asia

China:

Guangdong Wolter Chemco Ventilation Ltd.
Boluo, Huizhou, Guangdong

Dongguan Wolter Chemco Ventilation Ltd.

Shipai, Dongguan, Guangdong
T +86 (0) 769 / 8655 7298
F +86 (0) 769 / 8655 7278
info@wolter.com.hk

Taizhou Wolter Ventilation Co. Ltd.

Hengjie, Luqiao District,
Taizhou, Zhejiang
T +86 (0) 576 / 26 22 666 (26 52 888)
F +86 (0) 576 / 26 56 830

China - Hong Kong, Macau:

Wolter Asia Ltd
Kowloon, Hong Kong
T +852 (0) 2456 0198
F +852 (0) 2456 0290
info@wolter.com.hk

China - Taiwan:

Waxlink International Co., Ltd.
8F-2 No.218 Roosevelt Rd.,
Sec.6, Taipei, Taiwan
T +886 (0) 2 / 8932 1196
F +886 (0) 2 / 8932 1197
waxlink@mail.waxlinktw.com

India:

Wolter Ventilators India Pvt. Ltd.
867 D, Block-A, Sushant Lok, Phase-I,
Gurgaon - 122009 (Haryana)
T +91 (0) 124 2577797, 4261001-3
sales@wolterindia.in

Korea:

Kaceco-Wolter
14-1, Dang-dong, Gunpo-shi,
Gyeonggi-do
T +(82) 0 31 / 4773 104
F +(82) 0 31 / 4773 132
wolter@kaceco.com
info@kaceco.com

Malaysia:

Vibrantech (M) Sdn Bhd.
47200 Petaling Jaya Selangor
T +603 (0) 7847 3500
F +603 (0) 7847 3380
sales@vibrantech-sb.com

Singapore:

Wolter Pte. Ltd.
SG-569738 Singapore
T +65 (0) 63 / 52 95 48
F +65 (0) 63 / 52 95 47
info@wolterfans.com.sg

Thailand:

Wolter Ventilation Co., Ltd.
Thamai Kratumban Samutsakorn
741 10 Thailand
T +66 (0) 84 555 2936
kongsakol@wolterfan.com

Australia

The Sydney Fan Company.
NSW 2147, Sydney, Australia
T +61 (0) 2 / 9624 4000
F +61 (0) 2 / 9624 4100
sales@thesydneyfancompany.com

Wolter GmbH Maschinen-und Apparatebau KG

Am Wasen 11
DE-76316 Malsch / Germany
T +49 (0) 72 04 / 92 01 0
F +49 (0) 72 04 / 92 01 11
www.wolter.eu
info@wolter.eu





Air In Motion

Guangdong Wolter Chemco Ventilation Ltd. (Wolter Asia)

Jigongkeng Administrative Zone, Futian Town, Boluo,

Huizhou City, Guangdong Province, P.R.China

www.wolter.com.hk

info@wolter.com.hk

